

**DAIKIN**



# INSTALLATION MANUAL

**VRV X** System Air Conditioner

RXYQ6ARY6  
RXYQ8ARY6  
RXYQ10ARY6  
RXYQ12ARY6  
RXYQ14ARY6  
RXYQ16ARY6  
RXYQ18ARY6  
RXYQ20ARY6



# Installation manual

## Contents

	Page
<b>Installation manual</b> .....	<b>1</b>
1. Definitions.....	1
1.1. Meaning of warnings and symbols.....	1
1.2. Meaning of used terms.....	2
2. General safety precautions.....	2
2.1. Safety precautions.....	2
2.2. Special notice of product.....	3
2.3. Disposal requirements.....	3
3. Introduction.....	4
3.1. General information.....	4
3.2. Combination.....	4
3.3. Scope of the manual.....	4
4. Accessories.....	4
4.1. Accessories supplied with this unit.....	4
4.2. Optional accessories.....	5
5. Overview of unit.....	5
5.1. Opening the unit.....	5
5.2. Main components in the unit.....	5
5.3. Main components in the electrical component box.....	7
6. Selecting an installation location.....	7
6.1. General precautions on installation.....	7
6.2. Weather related precautions.....	8
6.3. Selecting a location in cold climates.....	8
7. Dimensions and service space.....	8
7.1. Dimensions of outdoor unit.....	8
7.2. Service space.....	9
8. Inspecting and handling the unit.....	9
8.1. Inspection.....	9
8.2. Handling.....	9
8.3. Installing the unit.....	10
9. Refrigerant pipe size and allowable pipe length.....	10
9.1. Selection of piping material.....	10
9.2. Selection of piping size.....	10
9.3. Selection of refrigerant branch kits.....	12
9.4. System piping (length) limitations.....	12
9.5. Multi system piping installation.....	15
10. Precautions on refrigerant piping.....	16
10.1. Caution for brazing.....	16
10.2. Connecting the refrigerant piping.....	17
10.3. Guidelines for handling stop valve.....	19
10.4. Leak test and vacuum drying.....	20
11. Pipe insulation.....	21
12. Electrical wiring work.....	21
12.1. Precautions on electrical wiring work.....	21
12.2. System overview of field wiring.....	22
12.3. Opening and closing the electrical component box.....	22
12.4. Requirements.....	23
12.5. Routing.....	23
12.6. Connection.....	26
13. Making field settings.....	28
13.1. Accessing the push buttons on the logic board.....	28
13.2. Operating the push buttons and DIP switches on the logic board.....	28
14. Charging refrigerant.....	30
14.1. Precautions.....	30
14.2. Calculating the additional refrigerant charge.....	30
14.3. Method for adding refrigerant.....	31
15. Monitoring function and field settings.....	34
15.1. Mode 1.....	34
15.2. Mode 2.....	35
15.3. Energy saving and optimum operation.....	37
16. Test run.....	38
16.1. Test operation.....	38
16.2. Malfunction code list.....	39
17. Operation of the unit.....	42
18. Caution for refrigerant leaks.....	42
18.1. Introduction.....	42
18.2. Maximum concentration level.....	42
18.3. Procedure for checking maximum concentration.....	42

Thank you for purchasing this Daikin VRV system.



**CAREFULLY READ THESE INSTRUCTIONS BEFORE INSTALLATION. THEY WILL TELL YOU HOW TO INSTALL AND HOW TO CONFIGURE THE UNIT PROPERLY. KEEP THIS MANUAL IN A HANDY PLACE FOR FUTURE REFERENCE.**

## 1. Definitions

### 1.1 Meaning of warnings and symbols

Warnings in this manual are classified according to their severity and probability of occurrence.



#### **DANGER**

Indicates an imminently hazardous situation, which if not avoided, will result in death or serious injury.



#### **WARNING**

Indicates a potentially hazardous situation, which if not avoided, could result in death or serious injury.



#### **CAUTION**

Indicates a potentially hazardous situation, which if not avoided, may result in minor or moderate injury. It may also be used to alert against unsafe practices.



#### **NOTICE**

Indicates situations that may result in equipment or property-damage accidents only.



#### **INFORMATION**

This symbol identifies useful tips or additional information.

Some types of danger are represented by special symbols:



#### **Electric current.**



#### **Danger of burning and scalding.**

## 1.2 Meaning of used terms

### Installation manual:

Instruction manual specified for a certain product or application, explaining how to install, configure and maintain it.

### Operation manual:

Instruction manual specified for a certain product or application, explaining how to operate it.

### Maintenance instructions:

Instruction manual specified for a certain product or application, which explains (if relevant) how to install, configure, operate and/or maintain the product or application.

### Dealer:

Sales distributor for products as per the subject of this manual.

### Installer:

Technical skilled person who is qualified to install products as per the subject of this manual.

### User:

Person who is owner of the product and/or operates the product.

### Service company:

Qualified company which can perform or coordinate the required service to the unit.

### Applicable legislation:

All international, European, national and local directives, laws, regulations and/or codes which are relevant and applicable for a certain product or domain.

### Accessories:

Equipment which is delivered with the unit and which needs to be installed according to instructions in the documentation.

### Optional equipment:

Equipment which can optionally be combined to the products as per the subject of this manual.

### Field supply:

Equipment which needs to be installed according to instructions in this manual, but which are not supplied by Daikin.

## 2. General safety precautions

The precautions listed here are divided into the following four types. They all cover very important topics, so be sure to follow them carefully.



### DANGER: ELECTRICAL SHOCK

Switch off all power supply before removing the electrical component box service panel or before making any connections or touching electrical parts.

Do not touch any switch with wet fingers. Touching a switch with wet fingers can cause electrical shock. Before touching electrical parts, turn off all applicable power supply.

To avoid electric shock, be sure to disconnect the power supply 1 minute or more before servicing the electrical parts. Even after 1 minute, always measure the voltage at the terminals of the main terminal, main circuit capacitors or electrical parts and before touching, be sure that those voltages are 50 V DC or less.

When service panels are removed, live parts can easily be touched by accident. Never leave the unit unattended during installation or servicing when the service panel is removed.



### DANGER: DO NOT TOUCH PIPING AND INTERNAL PARTS

Do not touch the refrigerant piping, water piping or internal parts during and immediately after operation. The piping and internal parts may be hot or cold depending on the working condition of the unit.

Your hand may suffer burns or frostbite if you touch the piping or internal parts. To avoid injury, give the piping and internal parts time to return to normal temperature or if you must touch them, be sure to wear protective gloves.

Also, at least, following information shall be provided at an accessible place of the system:

- Instructions for shutting down the system in case of an emergency.
- Name and address of fire department, police and hospital.
- Name, address and day and night telephone numbers for obtaining service.

## FIRST OF ALL

- This document is an installation manual for the Daikin RXYQ Series VRV Inverter. Before installing the unit, read this manual thoroughly and following the instructions contained in it. After installation, do a test run to make sure the unit runs properly and then explain how to operate and take care of the unit to the customer, using the operation manual.
- Lastly, make sure the customer keeps this manual, along with the operation manual in a safe place.
- This manual does not describe how to install the indoor unit. Refer to the installation manual included with the indoor unit for that.

### 2.1 Safety precautions

Please read these "Safety precautions" carefully before installing air conditioning unit and be sure to install it correctly.

After completing the installation, make sure that the unit operates properly during the start-up operation.

**Also, inform customers that they should store this installation manual along with the operation manual for future reference.**

After completing installation, conduct a trial operation to check for faults and explain to the customer how to operate the air conditioner and take care of it with the aid of operation manual. Ask the customer to store the installation manual along with the operation manual for future reference.

**This air conditioner comes under the term "appliances not accessible to the general public".**

**Please instruct the customer on how to operate the unit and keep it maintained.**

Meaning of WARNING and CAUTION notices



**WARNING**.....Failure to follow these instructions properly may result in personal injury or loss of life.



**CAUTION**.....Failure to observe these instructions properly may result in property damage or personal injury, which may be serious depending on the circumstances.



## WARNING

- Ask your dealer or qualified personnel to carry out installation work. Do not attempt to install the air conditioner yourself. Improper installation may result in water leakage, electric shocks or fire.
- Consult your local regarding what to do in case of refrigerant leakage, when the air conditioner is to be installed in a small room, it is necessary to take proper measures so that the amount of any leaked refrigerant does not exceed the concentration limit in case event of leakage. Otherwise, this may lead to an accident due to oxygen depletion.
- Install the air conditioner in accordance with the instructions in this installation manual. Improper installation may result in water leakage, electric shocks or fire.
- When installing the unit in a small room, take measures against to keep refrigerant concentration from exceeding allowable safety limits in case event of refrigerant leakage. Contact the place of purchase for more information. Excessive refrigerant in a closed ambient can lead to oxygen deficiency.
- Be sure to use only the specified accessories and parts for installation work. Failure to use the specified parts may result in the unit falling, water leakage, electric shocks or fire.
- Install the air conditioner on a foundation strong enough to withstand the weight of the unit. A foundation of insufficient strength may result in the equipment falling and causing injury.
- Carry out the specified installation work after taking into account strong winds, typhoons or earthquakes. Failure to do so during installation work may result in the unit falling and causing accidents.
- Make sure that a separate power supply circuit is provided for this unit and that all electrical work is carried out by qualified personnel according to local laws and regulations and this installation manual. An insufficient power supply capacity or improper electrical construction may lead to electric shocks or fire.
- Make sure that all wiring is secured, the specified wires are used and that there is no strain on the terminal connections or wires. Improper connections or securing of wires may result in abnormal heat build-up or fire.
- When wiring the power supply and connecting the remote controller wiring and transmission wiring, position the wires so that the EL.COMPO.BOX lid can be securely fastened. Improper positioning of the EL.COMPO.BOX lid may result in electric shocks, fire or the terminals overheating.
- If refrigerant gas leaks during installation, ventilate the area immediately. Toxic gas may be produced if the refrigerant comes into contact with fire.
- After completing installation, check for refrigerant gas leakage. Toxic gas may be produced if the refrigerant gas leaks into the room and comes into contact with a source of fire, such as a fan heater, stove or cooker.
- Do not directly touch refrigerant that has leaked from refrigerant pipes or other areas, as there is a danger of frostbite.
- Be sure to switch off the unit before touching any electrical parts.
- Do not allow children to climb on the outdoor unit and avoid placing objects on the unit. Injury may result if the unit becomes loose and falls.
- Be sure to earth the air conditioner. Do not earth the unit to a utility pipe, lightning conductor or telephone earth lead. Imperfect earthing may result in electric shocks or fire. A high surge current from lightning or other sources may cause damage to the air conditioner.
- Be sure to install an earth leakage breaker. Failure to install an earth leakage breaker may result in electric shocks or fire.



## CAUTION

- While following the instructions in this installation manual, install drain piping to ensure proper drainage and insulate piping to prevent condensation. Improper drain piping may result in indoor water leakage and property damage.
- Install the indoor and outdoor units, power cord and connecting wires at least 1 meter away from televisions or radios to prevent picture interference and noise. (Depending on the incoming signal strength, a distance of 1 meter may not be sufficient to eliminate noise.)
- Remote controller (wireless kit) transmitting distance can be shorter than expected in rooms with electronic fluorescent lamps (inverter or rapid start types). Install the indoor unit as far away from fluorescent lamps as possible.
- Make sure to provide for adequate measures in order to prevent that the outdoor unit be used as a shelter by small animals. Small animals making contact with electrical parts can cause malfunctions, smoke or fire. Please instruct the customer to keep the area around the unit clean.
- Do not install the air conditioner in the following locations:
  1. Where there is a high concentration of mineral oil spray or vapour (e.g. a kitchen). Plastic parts will deteriorate, parts may fall off and water leakage could result.
  2. Where corrosive gas, such as sulphurous acid gas, is produced. Corroding of copper pipes or soldered parts may result in refrigerant leakage.
  3. Near machinery emitting electromagnetic radiation. Electromagnetic radiation may disturb the operation of the control system and result in a malfunction of the unit.
  4. Where flammable gas may leak, where there is carbon fibre or ignitable dust suspensions in the air or where volatile flammables such as paint thinner or gasoline are handled. Operating the unit in such conditions may result in fire.
- In a domestic environment this product may cause radio interference in which case the user may be required to take adequate measures.

## 2.2 Special notice of product

### [REFRIGERANT]

#### VRV System use R410A refrigerant.

- The refrigerant R410A requires that strict precautions be observed for keeping the system clean, dry and tightly sealed. Read the chapter "REFRIGERANT PIPING" carefully and follow these procedures correctly.
  - A. Clean and dry  
Strict measures must be taken to keep impurities (including SUNISO oil and other mineral oils as well as moisture) out of the system.
  - B. Tight sealed  
Take care to keep the system tight when installing. R410A contains no chlorine, does not destroy the ozone layer and so does not reduce the earth's protection against harmful ultraviolet radiation. R410A will contribute only slightly to the greenhouse effect if released into the atmosphere.

### [DESIGN PRESSURE]

Since design pressure is 4.0 MPa or 40 bar (for R407C units : 3.3 MPa or 33 bar) the thickness of pipes must be greater than previously. Since R410A is a mixed refrigerant, the required additional refrigerant must be charged in its liquid state. (If the system is charged with refrigerant in its gaseous state, due to compositions change, the system will not function normally). The indoor units is designed for R410A use. See the catalogue for indoor unit models that can be connected. (Normal operation is not possible when connecting units that are originally designed for other refrigerants)

## 2.3 Disposal requirements

Dismantling of the unit, treatment of the refrigerant, of oil and of other parts must be done in accordance with relevant local and national legislation.

### 3. Introduction

#### 3.1 General information

This installation manual concerns the VRV, full inverter driven, heat pump system.

Depending on the type of outdoor unit which is chosen, some functionality will or will not exist. It will be indicated throughout this installation manual and brought to your attention. Certain features have exclusive model rights.

These units have (in single use) heating capacities ranging from 18 to 63 kW and cooling capacities rating from 16 to 56 kW. In multi combination the heating capacity can go up till 189 kW and in cooling till 168 kW.

The outdoor unit is designed to work in heating mode at ambient temperatures from -20°C to 21°C and in cooling mode at ambient temperatures from -5°C to 49°C.

**NOTICE**  
Design of the system must not be done at temperatures below -15°C.

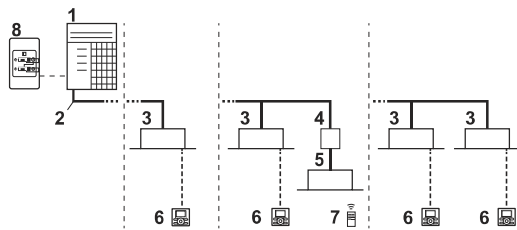

- 1 VRV heat pump outdoor unit
- 2 Refrigerant piping
- 3 VRV indoor unit
- 4 BP unit (required to connect Residential Air (RA) indoor units)
- 5 Residential Air (RA) indoor unit.
- 6 User interface (dedicated depending on indoor unit type)
- 7 User interface (wireless, dedicated depending on indoor unit type)
- 8 Cool/Heat changeover remote control switch

#### 3.2. Combination

The indoor units can be installed in the following range.

(Outdoor unit)	(Combination)	(Total capacity of indoor units)
RXYQ6A	Single unit	75 ~ 195
RXYQ8A	Single unit	100 ~ 260
RXYQ10A	Single unit	125 ~ 325
RXYQ12A	Single unit, Multi unit <sup>(a)</sup>	150 ~ 390
RXYQ14A	Single unit, Multi unit <sup>(a)</sup>	175 ~ 455
RXYQ16A	Single unit, Multi unit <sup>(a)</sup>	200 ~ 520
RXYQ18A	Single unit, Multi unit <sup>(a)</sup>	225 ~ 585
RXYQ20A	Single unit, Multi unit <sup>(a)</sup>	250 ~ 650
RXYQ22A	Multi unit	275 ~ 715
RXYQ24A	Multi unit	300 ~ 780
RXYQ26A	Multi unit	325 ~ 845
RXYQ28A	Multi unit	350 ~ 910
RXYQ30A	Multi unit	375 ~ 975
RXYQ32A	Multi unit	400 ~ 1,040
RXYQ34A	Multi unit	425 ~ 1,105
RXYQ36A	Multi unit	450 ~ 1,170
RXYQ38A	Multi unit	475 ~ 1,235
RXYQ40A	Multi unit	500 ~ 1,300
RXYQ42A	Multi unit	525 ~ 1,365
RXYQ44A	Multi unit	550 ~ 1,430
RXYQ46A	Multi unit	575 ~ 1,495
RXYQ48A	Multi unit	600 ~ 1,560
RXYQ50A	Multi unit	625 ~ 1,625
RXYQ52A	Multi unit	650 ~ 1,690
RXYQ54A	Multi unit	675 ~ 1,755
RXYQ56A	Multi unit	700 ~ 1,820
RXYQ58A	Multi unit	725 ~ 1,885
RXYQ60A	Multi unit	750 ~ 1,950

#### Note

- Be sure to connect an R410A indoor unit.
  - See the catalog for indoor unit models which can be connected.
  - Refer to the technical engineering data for multi unit combinations.
- (a) Outdoor unit can be connected combination in single unit or multi unit, see more details in the technical engineering data.



#### NOTICE

When selecting the total capacity higher than mentioned in previously, cooling and heating capacity will drop. For additional information see technical engineering data.

- If the total capacity of the connected indoor units exceeds the capacity of the outdoor unit, cooling performance may drop when running the indoor units. See the capacity table in the Engineering Data Book for details.
- There are restrictions on the refrigerant pipe connecting order between outdoor unit in the case of the multi system. Install so that the following restrictions are satisfied.

<Restrictions>  
The capacities of outdoor units A, B and C must fulfill the following conditions.  
**A ≥ B ≥ C**

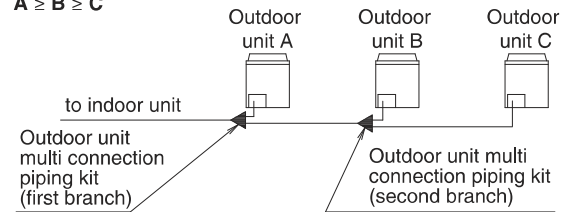

#### 3.3 Scope of the manual

This manual describes the procedures for handling, installing and connecting the VRV heat pump outdoor units. This manual has been prepared to ensure adequate maintenance of the unit, and it will provide help in case problems occur.



#### INFORMATION

The installation of the indoor unit(s) is described in the indoor unit installation manual provided with the indoor units.

## 4. Accessories

#### 4.1 Accessories supplied with this unit

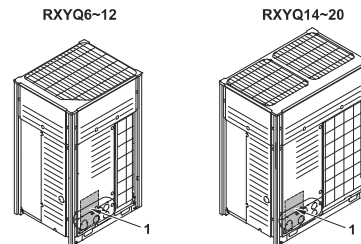

See location 1 in the figure above for reference to where following accessories are supplied with the unit.

Name	Tie wrap (1)	Tie wrap (2)	Tie wrap (3)	Gas accessory pipe (1)	
Quantity	9 pcs.	1 pc.	1 pc.	1 pc.	
Shape				Front connection	
	Small		Large		

Name	Gas accessory pipe (2)	Liquid accessory pipe (1)	Liquid accessory pipe (2)	Others
Quantity	1 pc.	1 pc.	1 pc.	<ul style="list-style-type: none"> <li>• Operation manual</li> <li>• Installation manual</li> <li>• Caution label (Addition refrigerant charge record)</li> </ul>
Shape	Bottom connection	Front connection	Bottom connection	

#### Note

(a) For RXYQ20, Front connection pipe require the combination of gas accessory pipe(1) and gas accessory pipe(2).

Do not leave any accessories supplied with this unit, until installation finished.

## 4.2 Optional accessories

To install the outdoor units, the following optional parts are also required. To select an optimum kit, refer to "9.3 Selection of refrigerant branch kits."

#### • Refrigerant branching kit

REFNET header	KHRP26M22H	KHRP26M33H	KHRP26M72H	KHRP26M73H
REFNET joint	KHRP26A22T	KHRP26A33T	KHRP26A72T	KHRP26A73T

#### • Outdoor unit multi connection piping kit

Number of outdoor units connected	2 units	3 units
Kit name	BHFP22P100	BHFP22P151

#### • Pipe size reducer

Kit name	KHRP26M73TP	KHRP26M73HP
----------	-------------	-------------

#### Note

Make sure that any separate purchased accessories are designed for use with R410A.

## 5. Overview of unit

### 5.1 Opening the unit

To gain access to the unit, front plates need to be opened as follows:

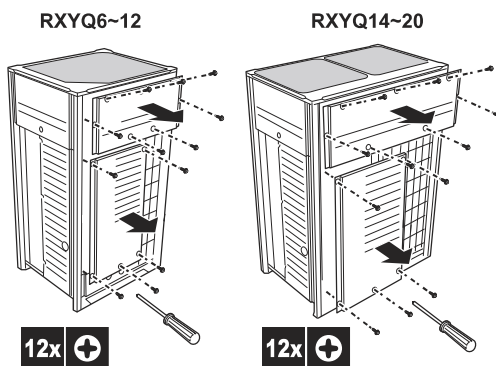

Once the front plates open, the electrical component box can be accessed by removing the electrical component box cover as follows.

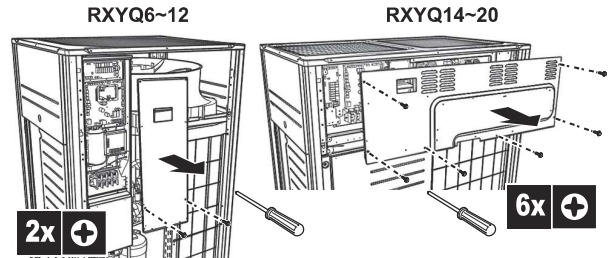

For service purposes, the push buttons on the main PCB need to be accessed. To access these push buttons, the electrical component box cover does not need to be opened. See "13.Making field settings".



#### **DANGER: Electrical shock**

See "2.General safety precautions".



#### **DANGER: Do not touch piping and internal parts.**

See "2.General safety precautions".

### 5.2 Main components in the unit

For all the models a piping diagram and outlook drawing are available. Depending on the model type some components in the main component list may not be existing in the unit.

#### Main components (see 5.2.1, 5.2.2)

- 1 Compressor (M1C)
- 2 Compressor (M2C)
- 3 Heat exchanger
- 4 Fan
- 5 Fan motor (M1F, M2F)
- 6 Accumulator
- 7 Expansion valve, main (Y1E)
- 8 Expansion valve, subcool heat exchanger (Y2E)
- 9 Expansion valve, refrigerant jacket (Y3E)
- 10 Expansion valve, refrigerant auto charge (Y4E)
- 11 Subcool heat exchanger
- 12 Oil separator
- 13 4 way valve, main (Y1S)
- 14 Solenoid valve, oil accumulator (Y2S)
- 15 Solenoid valve, oil separator 1 (Y3S)
- 16 Solenoid valve, oil separator 2 (Y4S)
- 17 Electrical component box
- 18 Stop valve, liquid
- 19 Stop valve, gas
- 20 Stop valve, automatic refrigerant charge.

### 5.2.1 RXYQ\* (6~12 HP)

#### Piping diagram

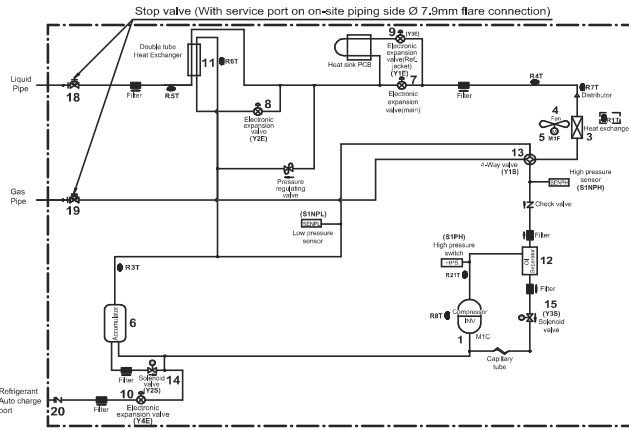

### 5.2.2 RXYQ\* (14~20 HP)

#### Piping diagram

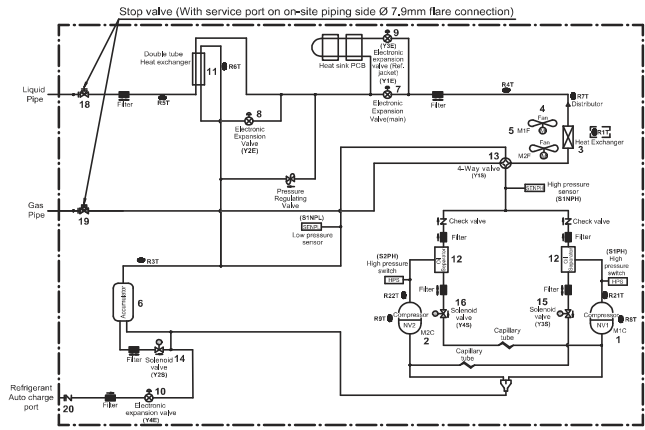

#### Outlook drawing

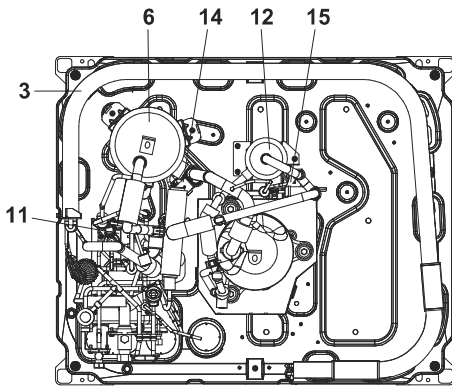

#### Outlook drawing

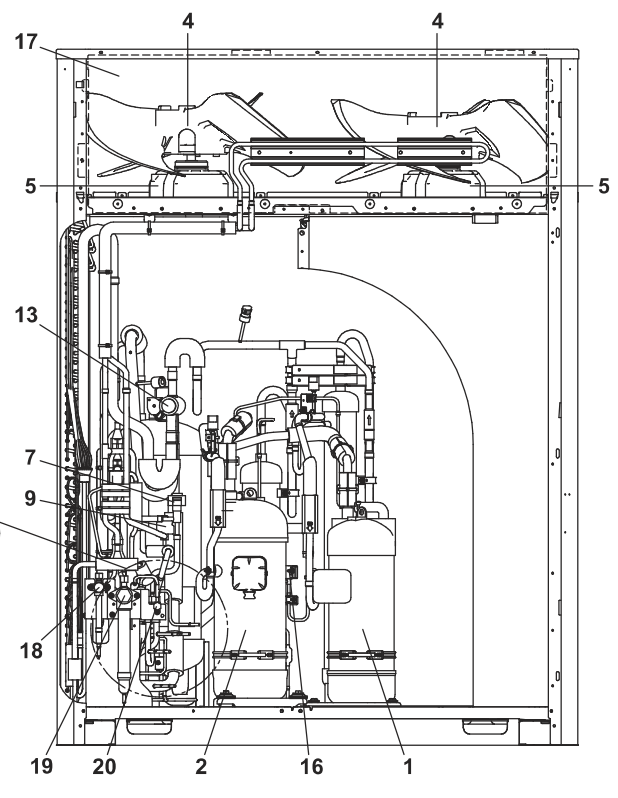
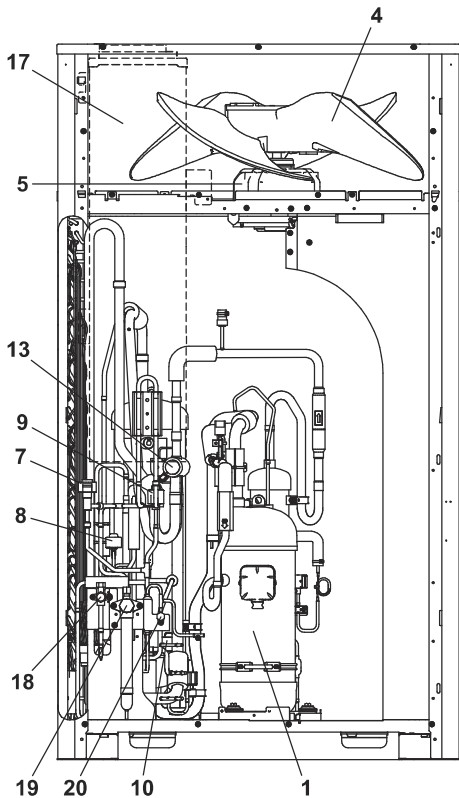
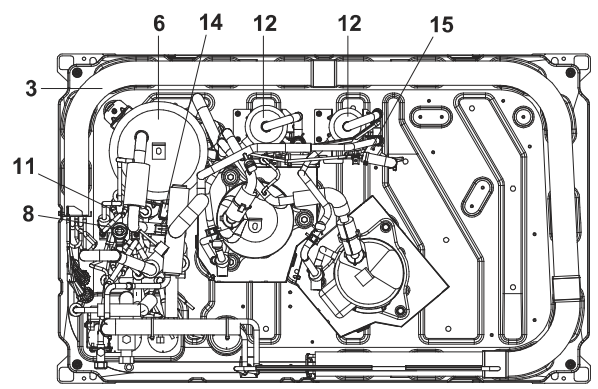



### 5.3 Main components in the electrical component box

RXYQ6~12

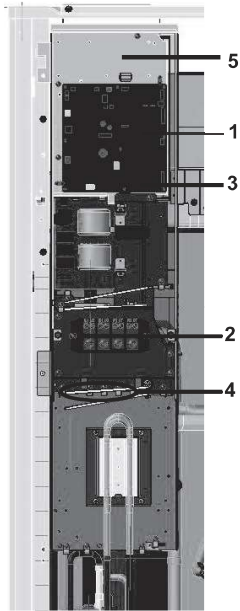

RXYQ14~20

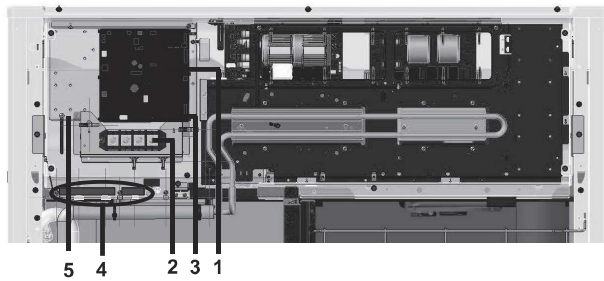

- 1 Main PCB.
- 2 Terminal block X1M: main terminal block which allows easy connection of field wiring for power supply.
- 3 Terminal X1M on main PCB: terminal block for transmission wiring.
- 4 Cable tie mountings: the cable tie mountings allow to fix the field wiring with cable ties to the electrical component box to ensure strain relief.
- 5 Over voltage PCB.



#### INFORMATION

For more details refer to the wiring diagram of the units. The wiring diagram is located on the inside of the electrical component box.

## 6. Selecting an installation location



#### CAUTION

Appliance not accessible to the general public, install it in a secured area, protected from easy access.

This unit, both indoor and outdoor, is suitable for installation in a commercial and light industrial environment.

### 6.1 General precautions on installation

Select an installation site that meets the following requirements:

- The foundation must be strong enough to support the weight of the unit. The floor is flat to prevent vibrations and noise generation and to have sufficient stability.
- The space around the unit is adequate for maintenance and servicing. The space around the unit allows for sufficient air circulation.
- There is no danger of fire due to leakage of flammable gas.
- The equipment is not intended for use in a potentially explosive atmosphere.
- Select the location of the unit in such a way that the sound generated by the unit does not disturb anyone and the location is selected according to the applicable legislation.
- All piping lengths and distances have been taken into consideration (refer "9.4 System piping (length) limitations").
- Take care that in the event of a water leak, water cannot cause any damage to the installation space and surroundings.
- When installing the unit in a smallroom, take measures in order to keep the refrigerant concentration from exceeding allowable safety limits in the event of a refrigerant leak.



#### CAUTION

Excessive refrigerant concentrations in a closed room can lead to oxygen deficiency.



#### NOTICE

The equipment described in this manual may cause electronic noise generated from radio-frequency energy. The equipment complies to specifications that are designed to provide reasonable protection against such interference. However, there is no guarantee that interference will not occur in a particular installation.

It is therefore recommended to install the equipment and electric wires keeping proper distances away from stereo equipment, personal computers, etc.

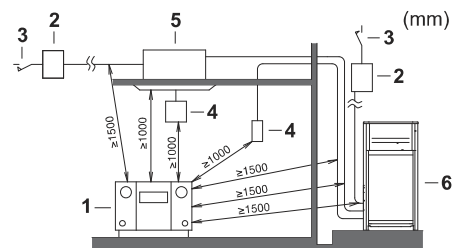

- 1 Personal computer or radio
- 2 Fuse
- 3 Earth leakage protector
- 4 User interface
- 5 Indoor unit
- 6 Outdoor unit

In places with weak reception, keep distances of 3 m or more to avoid electromagnetic disturbance of other equipment and use conduit tubes for power and transmission lines.

- The refrigerant R410A itself is nontoxic, non-flammable and is safe. In case the refrigerant leaks its concentration may exceed the allowable limit depending on room size. Due to this, it could be necessary to take measures against leakage. (See "18. Caution for refrigerant leaks").
- Do not install in the following locations:
  - Locations where sulphurous acids and other corrosive gases may be present in the atmosphere. Copper piping and soldered joints may corrode, causing refrigerant to leak.
  - Locations where a mineral oil mist, spray or vapour may be present in the atmosphere. Plastic parts may deteriorate and fall off or cause water leakage.
  - Locations where equipment that produces electromagnetic waves is found. The electromagnetic waves may cause the control system to malfunction, preventing normal operation.
  - Locations where flammable gases may leak, where thinner, gasoline and other volatile substances are handled or where carbon dust and other combustible substances are found in the atmosphere. Leaked gas may accumulate around the unit, causing an explosion.
- When installing, take strong winds, typhoons or earthquakes into account, improper installation may result in the unit turning over.

### 6.2 Weather related precautions

- Select a place where the rain can be avoided as much as possible.
- Be sure that the air inlet of the unit is not positioned towards the main wind direction. Frontal wind will disturb the operation of the unit. If necessary, use a screen to block the wind.
- Ensure that water cannot cause any damage to the location by adding water drains to the foundation and prevent water traps in the construction.
- Do not install the unit in areas where the air contains high levels of salt such as that near the ocean.

### 6.3 Selecting a location in cold climates



#### NOTICE

When operating the unit in a low outdoor ambient temperature, be sure to follow the instructions described below.

To prevent exposure to wind and snow, install a baffle plate on the air side of the outdoor unit:

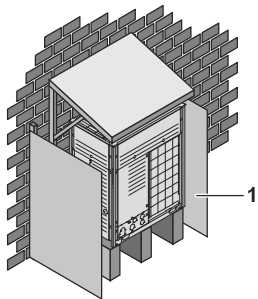

1 Baffle plate

In heavy snowfall areas it is very important to select an installation site where the snow will not affect the unit. If lateral snowfall is possible, make sure that the heat exchanger coil is not affected by the snow (if necessary construct a lateral canopy).

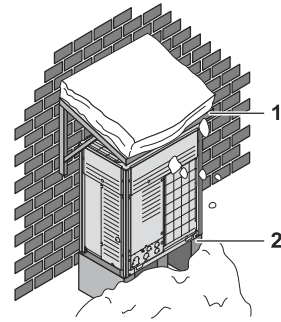

- 1 Construct a large canopy.
- 2 Construct a pedestal. Install the unit high enough from the ground to prevent burying in snow.

## 7. Dimensions and service space

### 7.1 Dimensions of outdoor unit

#### RXYQ6~12

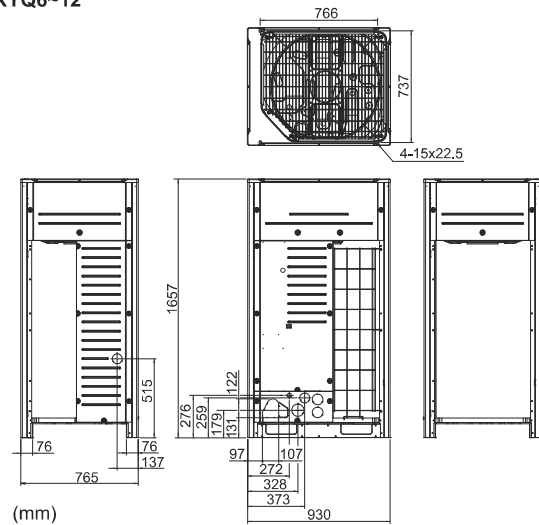

#### RXYQ14~20

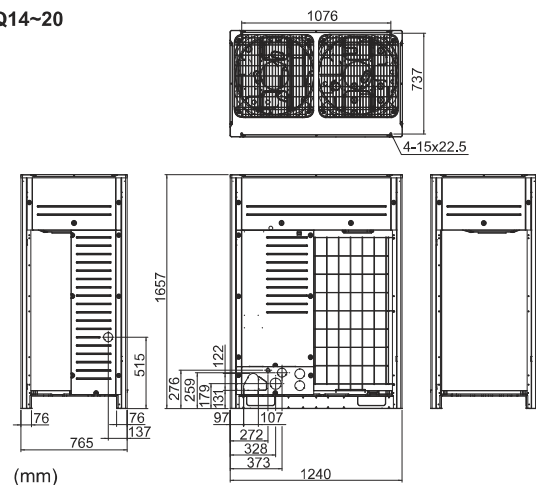

## 7.2 Service space

The space around the unit is adequate for servicing and the minimum space for air inlet and air outlet is available (refer to the figure below and choose one of the possibilities).

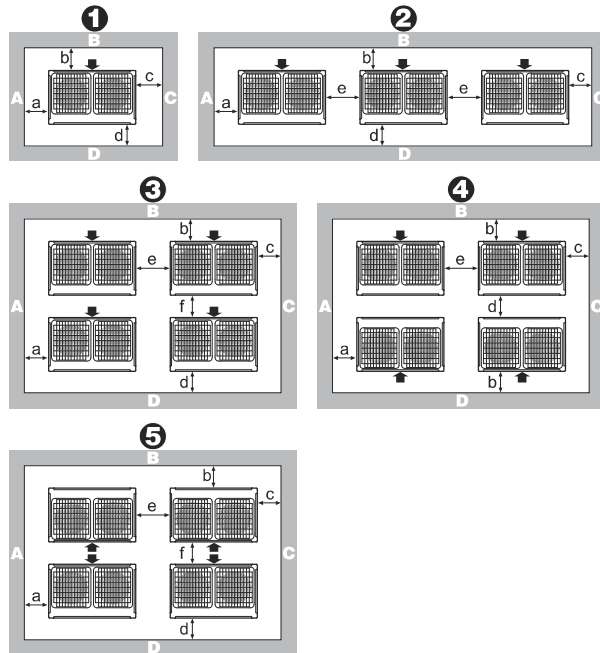

	A+B+C+D		A+B
1	a ≥ 10 mm b ≥ 300 mm c ≥ 10 mm d ≥ 500 mm	a ≥ 50 mm b ≥ 100 mm c ≥ 50 mm d ≥ 500 mm	a ≥ 200 mm b ≥ 300 mm
2	a ≥ 10 mm b ≥ 300 mm c ≥ 10 mm d ≥ 500 mm e ≥ 20 mm	a ≥ 50 mm b ≥ 100 mm c ≥ 50 mm d ≥ 500 mm e ≥ 100 mm	a ≥ 200 mm b ≥ 300 mm e ≥ 400 mm
3	a ≥ 10 mm b ≥ 300 mm c ≥ 10 mm d ≥ 500 mm e ≥ 20 mm f ≥ 600 mm	a ≥ 50 mm b ≥ 100 mm c ≥ 50 mm d ≥ 500 mm e ≥ 100 mm f ≥ 500 mm	
4	a ≥ 10 mm b ≥ 300 mm c ≥ 10 mm d ≥ 500 mm e ≥ 20 mm	a ≥ 50 mm b ≥ 100 mm c ≥ 50 mm d ≥ 500 mm e ≥ 100 mm	
5	a ≥ 10 mm b ≥ 500 mm c ≥ 10 mm d ≥ 500 mm e ≥ 20 mm f ≥ 900 mm	a ≥ 50 mm b ≥ 500 mm c ≥ 50 mm d ≥ 500 mm e ≥ 100 mm f ≥ 600 mm	

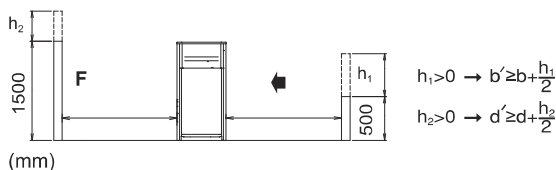

ABCD Sides along the installation site with obstacles  
 F Front side  
 ➔ Suction side

- In case of an installation site where sides A+B+C+D have obstacles, the wall heights of sides A+C have no impact on service space dimensions. Refer to the figure above for impact of wall heights of sides B+D on service space dimensions, calculate new b, d by referring above formula.

- In case of an installation site where only the sides A+B have obstacles, the wall heights have no influence on any indicated service space dimensions.
- The installation space required on these drawings are for full load heating operation without considering possible ice accumulation.  
 If the location of the installation is in a cold climate, then all dimensions above should be >500 mm to avoid accumulation of ice in between the outdoor units.

### **i** INFORMATION

- The service space dimensions in previously figure are based on cooling operation at 35°C ambient temperature (standard conditions).
- Further specifications can be found in the technical engineering data.

## 8. Inspecting and handling the unit

### 8.1 Inspection

At delivery, the unit must be checked and any damage must be reported immediately to the carrier's claims agent.

### 8.2 Handling

- When handling the unit, take into account the following:



Fragile, handle the unit with care.



Keep the unit upright in order to avoid compressor damage.

- Choose on beforehand the path along which the unit is to be brought in.
- Bring the unit as close as possible to its final installation position in its original package to prevent damage during transport.

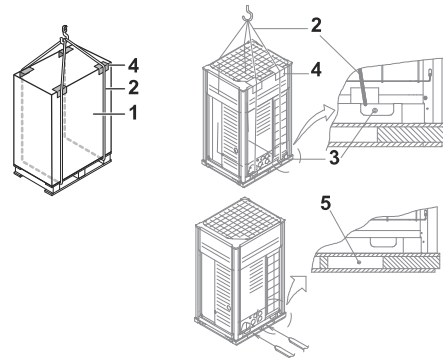

- Packaging material
- Belt sling
- Product opening
- Protector
- Skid base opening

- If use a forklift, insert the forks into the skid base opening.
- Lift the unit preferably with a crane and 2 belts sling of at least 8 m long as shown in the figure above.  
 Always use protectors to prevent belt sling damage and pay attention to the position of the unit's centre of gravity.

A forklift can only be used for transport as long as the unit remains on its pallet as shown above.

### 8.3 Installing the unit

Make sure the unit is installed level on a sufficiently strong base to prevent vibration and noise.



#### NOTICE

When the installation height of the unit needs to be increased, do not use stands support the corners only.

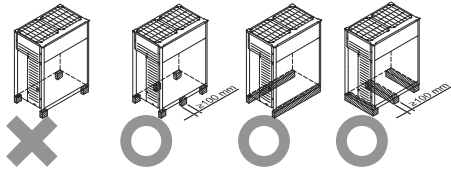

X Not allowed  
O Allowed

- The height of the foundation must at least be 150 mm from the floor.
- In heavy snowfall areas, this height should be increased, depending on the installation place and condition.
- The unit must be installed on a solid longitudinal foundation (steel beam frame or concrete) and make sure the base under the unit is larger than the grey marked area.

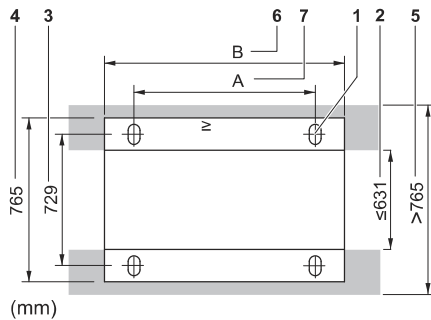

(mm)

- Hole for foundation bolt (Ø15 dia. : 4 positions)
- Inner dimension of the base
- Distance between foundation bolt holes
- Depth of unit
- Outer dimension of the base
- Longitudinal foundation dimension
- Distance between foundation bolt holes

Model	A	B
6 · 8 · 10 · 12HP type	766	930
14 · 16 · 18 · 20HP type	1076	1240

- Fasten the unit in place using four foundation bolts M12. It is best to screw in the foundation bolts until their length remains 20mm above the foundation surface.

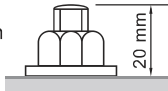

#### NOTICE

- Prepare a water drainage channel around the foundation to drain waste water from around the unit. During heating operation and when the outdoor temperatures are negative, the drained water from the outdoor unit will freeze up. If the water drainage is not taken care of, the area around the unit might be very slippery.
- When installed in a corrosive environment, use a nut with plastic washer to protect the nut tightening part from rust.

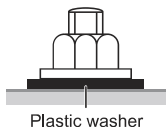

Plastic washer

## 9. Refrigerant pipe size and allowable pipe length

### 9.1 Selection of piping material



#### NOTICE

- Jointless phosphor-deoxidized copper pipe
- Select a thickness for the refrigerant piping which complies with national and local laws.
- Installation shall be done by a licensed installer, the choice of materials and installation shall confirm completely with the applicable national and international codes.

- Foreign materials inside pipes (including oils for fabrication) must be ≤30 mg/10 m.
- Temper grade: use piping with temper grade in function of the pipe diameter as listed in table below.

Pipe Ø (mm)	Temper grade of piping material
≤15.9 (5/8")	O (annealed)
≥19.1 (3/4")	1/2H (half hard)

### 9.2 Selection of piping size

Determine the proper size referring to following tables and reference figure.

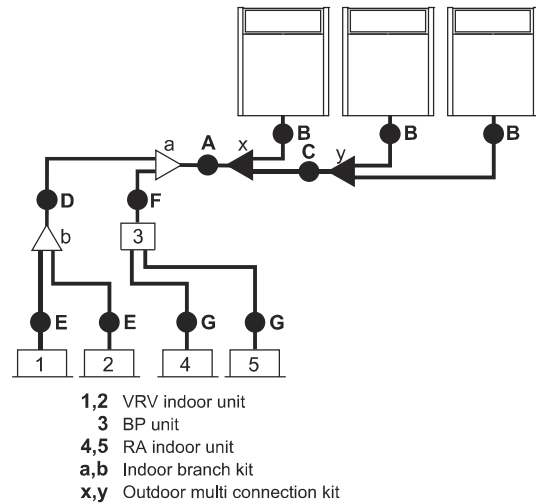

- 1,2 VRV indoor unit
- 3 BP unit
- 4,5 RA indoor unit
- a,b Indoor branch kit
- x,y Outdoor multi connection kit

#### 9.2.1 Piping between outdoor unit and (first) refrigerant branch kit: A, B, C

Choose from the following table in accordance with the outdoor unit total capacity type, connected downstream.

Outdoor unit capacity type (HP)	Piping outside diameter size (mm)	
	Gas pipe	Liquid pipe
6~8	Ø 19.1 (3/4")	Ø 9.5 (3/8")
10	Ø 22.2 (7/8")	
12~16	Ø 28.6 (1 1/8")	Ø 12.7 (1/2")
18~22		Ø 15.9 (5/8")
24	Ø 34.9 (1 3/8")	Ø 19.1 (3/4")
26~34	Ø 41.3 (1 5/8")	
36~60		

### 9.2.2 Piping between refrigerant branch kits: D

Choose from the following table in accordance with the indoor unit total capacity type, connected downstream. Do not let the connection piping exceed the refrigerant piping size chosen by the general system model name.

Total capacity index of connected indoor units.	Piping outside diameter size (mm)	
	Gas pipe	Liquid pipe
<150	Ø 15.9 (5/8")	Ø 9.5 (3/8")
150≤x<200	Ø 19.1 (3/4")	
200≤x<290	Ø 22.2 (7/8")	
290≤x<420	Ø 28.6 (1 1/8")	Ø12.7 (1/2")
420≤x<640		Ø15.9 (5/8")
640≤x<920	Ø 34.9 (1 3/8")	Ø19.1 (3/4")
≥920	Ø41.3 (1 5/8")	

#### Example:

Downstream capacity for **E**=capacity index of unit 1  
 Downstream capacity for **D**=capacity index of unit 1+capacity index of unit 2

### 9.2.3 Piping between refrigerant branch kit and BP unit: F

Pipe size for direct connection on BP unit must be based on the total capacity of the connected indoor units (only in case RA indoor units are connected).

Total capacity index to connected indoor units.	Piping outside diameter size (mm)	
	Gas pipe	Liquid pipe
20-62	Ø12.7 (1/2")	Ø 6.4 (1/4")
63-149	Ø15.9 (5/8")	Ø 9.5 (3/8")
150-208	Ø19.1 (3/4")	
~250	Ø 22.2 (7/8")	

#### Example:

Downstream capacity for **F**=capacity index of unit 4+capacity index of unit 5

### 9.2.4 Piping between BP unit and RA indoor unit: G

Only in case RA indoor units are connected.

Indoor unit capacity index	Piping outside diameter size (mm)	
	Gas pipe	Liquid pipe
20, 25, 30, 35	Ø 9.5 (3/8")	Ø 6.4 (1/4")
50	Ø12.7 (1/2")	
60		Ø 9.5 (3/8")
71 <sup>(c)</sup>	Ø15.9 (5/8")	

(c) In some indoor units, the piping size is difference.  
 Choose from the size of each indoor units.

### 9.2.5 Piping between refrigerant branch kit and indoor unit: E

Pipe size for direct connection to indoor unit must be the same as the connection size of the indoor unit (in case indoor unit is VRV Indoor).

Indoor unit capacity index	Piping outside diameter size (mm)	
	Gas pipe	Liquid pipe
20, 25, 32, 40, 50	Ø12.7 (1/2")	Ø 6.4 (1/4")
63, 80, 100, 125, 140	Ø15.9 (5/8")	Ø 9.5 (3/8")
200	Ø19.1 (3/4")	
250	Ø22.2 (7/8")	
400	Ø28.6 (1 1/8")	Ø 12.7 (1/2")
500		Ø 15.9 (5/8")

- When the equivalent pipe length between outdoor and indoor units is 90 m or more, the size of the main pipes (both gas side and liquid side) must be increased. Depending on the length of the piping, the capacity may drop, but even in such a case it is possible to increase the size of the main pipes.

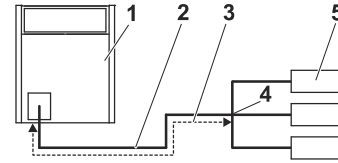

- Outdoor unit
- Main pipes
- Increase
- First refrigerant branch kit
- Indoor unit

Size up		
HP Class	Gas side (mm)	Liquid size (mm)
6~8	Ø19.1 (3/4") → Ø22.2 (7/8")	Ø9.5 (3/8") → Ø12.7 (1/2")
10	Ø22.2 (7/8") → Ø25.4 (1") <sup>(a)</sup>	
12~14	Ø28.6 (1 1/8") <sup>(b)</sup>	Ø12.7 (1/2") → Ø15.9 (5/8")
16	Ø28.6 (1 1/8") → Ø31.8 (1 1/4") <sup>(a)</sup>	
18~22	Ø34.9 (1 3/8") <sup>(b)</sup>	Ø15.9 (5/8") → Ø19.1 (3/4")
24	Ø34.9 (1 3/8") → Ø38.1 (1 1/2") <sup>(a)</sup>	
26~34	Ø41.3 (1 5/8") <sup>(b)</sup>	Ø19.1 (3/4") → Ø22.2 (7/8")
36~60	Ø41.3 (1 5/8") <sup>(b)</sup>	

(a) If this pipe diameter is not available on site, please do not size up a pipe diameter. (Without size up the pipe diameter, capacity will great decreased, but equivalent piping length can be extended up to 190m)

(b) Please use this pipe diameter only. (Without size up the pipe diameter, equivalent piping length can be extended up to 190m)

- The pipe thickness of the refrigerant piping shall comply with the applicable legislation. The minimal pipe thickness for R410A piping must be in accordance with the table below.

Pipe Ø (mm)	Minimal thickness t (mm)
Ø 6.4 (1/4")	0.80
Ø 9.5 (3/8")	
Ø 12.7 (1/2")	
Ø 15.9 (5/8")	0.99
Ø 19.1 (3/4")	0.80
Ø 22.2 (7/8")	
Ø 25.4 (1")	0.88
Ø 28.6 (1 1/8")	0.99
Ø 31.8 (1 1/4")	1.10
Ø 34.9 (1 3/8")	1.21
Ø 38.1 (1 1/2")	1.32
Ø 41.3 (1 5/8")	1.43

In this case, the additional refrigerant calculation has to be adjusted as mentioned in "14.Charging refrigerant".

### 9.3 Selection of refrigerant branch kits

#### Refrigerant REFNETS

For piping example, refer to "9.2. Selection of piping size".

- When using REFNET joints at the first branch counted from the outdoor unit side, choose from the following table in accordance with the capacity of the outdoor unit (example: REFNET joint a).

Outdoor unit capacity type (HP)	Model refrigerant branch kits
6~10	KHRP26A33T
12~22	KHRP26A72T
24~60	KHRP26A73T + KHRP26M73TP

- For REFNETS joints other than the first branch (example REFNET joint b), select the proper branch kit model based on the total capacity index of all indoor units connected after the refrigerant branch.

Indoor unit capacity index	Model refrigerant branch kits
<200	KHRP26A22T
200≤x<290	KHRP26A33T
290≤x<640	KHRP26A72T
≥640	KHRP26A73T + KHRP26M73TP

- Concerning REFNET headers, choose from the following table in accordance with the total capacity of all the indoor units connected below the REFNET header.

Indoor unit capacity index	Model refrigerant branch kits
<200	KHRP26M22H
200≤x<290	KHRP26M33H
290≤x<640	KHRP26M72H <sup>(a)</sup>
≥640	KHRP26M73H + KHRP26M73HP

(a) If the pipe size above the REFNET header is Ø34.9 or more, KHRP26M73HP is required.



#### INFORMATION

Maximum 8 branches can be connected to a header.

- How to choose an outdoor multi connection piping kit. Choose from the following table in accordance with the number of outdoor units.

Number of outdoor units	Branch kit name
2	BHFP22P100
3	BHFP22P151



#### NOTICE

Refrigerant branch kits can only be used with R410A.

### 9.4 System piping (length) limitations

#### 9.4.1 Piping length restrictions

Make sure to perform the piping installation within the range of the maximum allowable pipe length, allowable level difference and allowable length after branching as indicated below. The pattern will be discussed, including VRV indoor units combined with RA indoor units.

#### Definitions

Actual piping length: pipe length between outdoor<sup>(1)</sup> and indoor units.  
Equivalent piping length<sup>(2)</sup> : pipe length between outdoor<sup>(1)</sup> and indoor units.

Total piping length: total piping length from the outdoor<sup>(1)</sup> to all indoor units.

Difference in height between outdoor and indoor units: H1.

Difference in height between indoor and indoor units: H2.

Difference in height between outdoor and outdoor units: H3.

Difference in height between outdoor and BP unit: H4.

Difference in height between BP unit and BP unit: H5.

Difference in height between BP unit and RA indoor unit: H6.

(1) In case of multi outdoor system, re-read to the first outdoor unit multi connection piping kit as seen from the indoor unit.

(2) Assume equivalent piping length of REFNET joint=0.5 m and REFNET header=1 m (for calculation purposes).

### 9.4.2 System only containing VRV indoor units

#### System setup

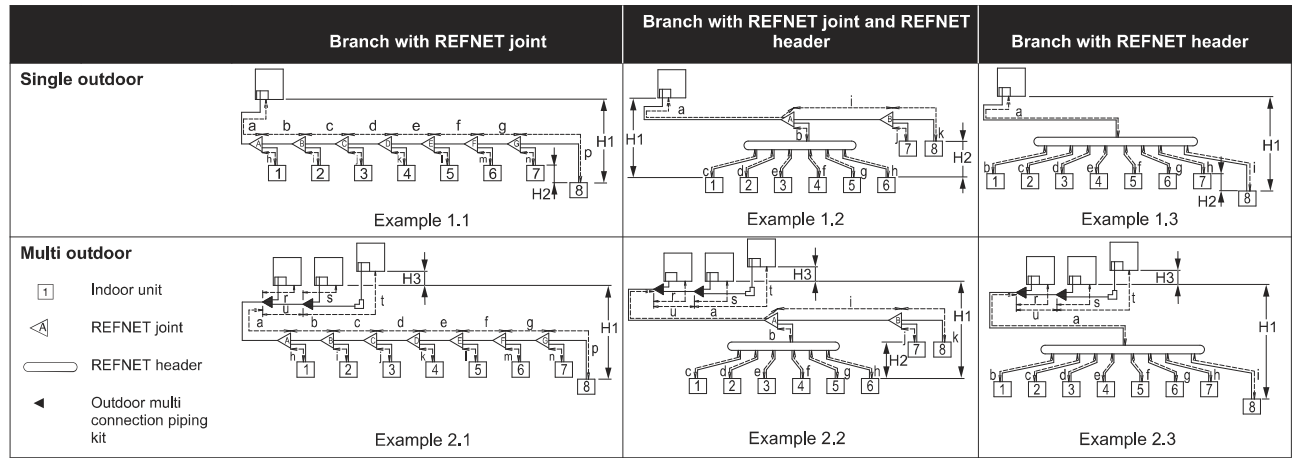

#### Maximum allowable length

- Between outdoor and indoor units (refer the recommended combination type in Engineering data book).

		Example 1.1	Example 1.2	Example 1.3
Actual piping length	165 m	unit 8: $a+b+c+d+e+f+g+p \leq 165$ m	unit 6: $a+b+h \leq 165$ m unit 8: $a+i+k \leq 165$ m	unit 8: $a+i \leq 165$ m
Equivalent length <sup>(2)</sup>	190 m	—	—	—
Total piping length	1000 m	$a+b+c+d+e+f+g+h+i+j+k+l+m+n+p \leq 1000$ m	—	—

- Between outdoor and indoor units (free multi combinations).

		Example 2.1	Example 2.2	Example 2.3
Actual piping length	135 m	unit 8: $a+b+c+d+e+f+g+p \leq 135$ m	unit 6: $a+b+h \leq 135$ m unit 8: $a+i+k \leq 135$ m	unit 8: $a+i \leq 135$ m
Equivalent length <sup>(2)</sup>	160 m	—	—	—
Total piping length	500 m	$a+b+c+d+e+f+g+h+i+j+k+l+m+n+p \leq 500$ m	—	—

**Example 3 : with standard multi layout**

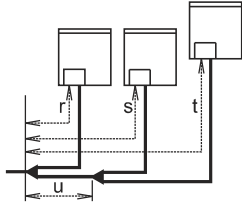

- Between outdoor branch and outdoor unit.

Actual piping length	10 m	Example 3 r, s, t ≤ 10 m; u ≤ 5 m
Equivalent length	13 m	—

**Maximum allowable height difference**

H1	≤ 50 m <sup>(a)</sup>
H2	≤ 30 m
H3	≤ 5 m

(a) Conditional extension up till 90 m is possible.  
 In case the outdoor location is higher than indoor: extension is possible up till 90 m and following 2 conditions must be fulfilled:  
 • Liquid piping size up (see table "Size up").  
 • Dedicated setting on outdoor unit is required (see [2-49] in Monitoring function and field settings)  
 In case the outdoor location is lower than indoor: extension is possible up till 90 m and following 1 condition must be fulfilled:  
 • Liquid piping size up (see table "Size up").

**Maximum allowable length after branch**

The pipe length from the first refrigerant branch kit to the indoor unit ≤ 40 m.

Example 1.1: unit 8:  $b+c+d+e+f+g+p \leq 40m$

Example 1.2: unit 6:  $b+h \leq 40m$ , unit 8:  $i+k \leq 40m$

Example 1.3: unit 8:  $i \leq 40m$

However, extension is possible if all below conditions are met. In this case limitation can be extended up to 90 m.

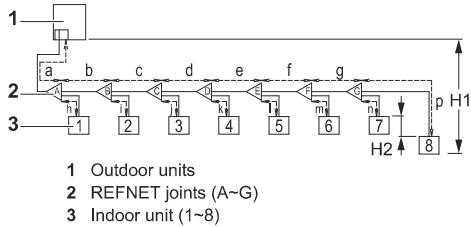

- a. The piping length between all indoor to the nearest branch kit is ≤ 40m.

Example: h, i, j ...  $p \leq 40$  m

- b. It is necessary to increase the pipe size of the gas and liquid piping if the pipe length between the first branch kit and the farthest indoor unit is over 40 m.

If the increased pipe size is larger than the pipe size of the main pipe, then the pipe size of the main pipe has to be increased as well.

Increase the pipe size as follows:  
 9.5 → 12.7; 12.7 → 15.9; 15.9 → 19.1; 19.1 → 22.2;  
 22.2 → 25.4<sup>(3)</sup>; 28.6 → 31.8<sup>(3)</sup>; 34.9 → 38.1<sup>(3)</sup>;

Example: unit 8:  $b+c+d+e+f+g+p \leq 90$  m; increase the pipe size of b, c, d, e, f, g.

(3) If this pipe diameter is unobtainable on site, please do not size up a pipe diameter. (Without size up the pipe diameter, capacity will great decreased, but equivalent piping length can be extended up to 190m)

- c. When the piping size is increased (step b), the piping length has to be counted as double (except for the main pipe and the pipes that are not increased in pipe size).

The total piping length has to be within limitations (see table previously).

Example:  
 $a+b*2+c*2+d*2+e*2+f*2+g*2+h+i+j+k+l+m+n+p \leq 1000$  m (500 m).

- d. The piping length difference between the nearest indoor from first branch to the outdoor unit and farthest indoor to the outdoor unit is ≤ 40 m.

Example: The farthest indoor unit 8. The nearest indoor unit 1 →  $(a+b+c+d+e+f+g+p)-(a+h) \leq 40$  m.

**9.4.3 System containing VRV indoor units and RA indoor units**

**System setup**

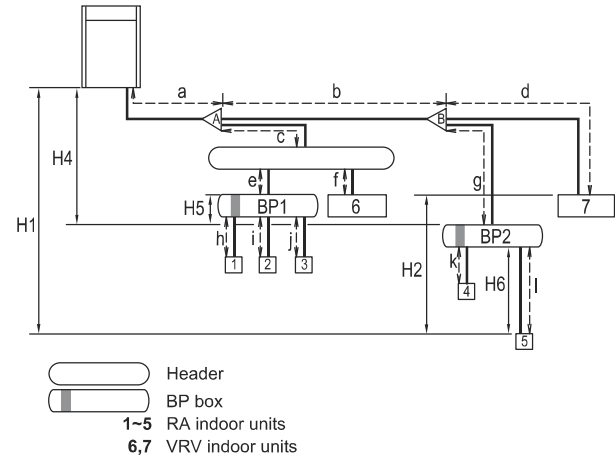

**Maximum allowable length**

- Between outdoor unit and indoor unit.

Actual piping length	100 m	Example: $a+b+g+l \leq 100$ m
Equivalent length <sup>(a)</sup>	120 m	—
Total piping length	250 m	Example: $a+b+d+g+l+k+c+e+f+h+i+j \leq 250$ m

(a) Assume equivalent piping length of REFNET joint=0.5 m and REFNET header=1 m (for calculation purposes).

- Between BP unit and indoor unit.

Indoor unit capacity index	Pipe length
<60	2~15 m
60	2~12 m
71	2~8 m

Remark: **Minimum allowable length** between outdoor unit and first refrigerant branch kit > 5 m (the refrigerant noise from the outdoor unit can be transmitted).

Example:  $a > 5$  m

**Maximum allowable height difference**

H1	≤ 50 m (40 m) (if outdoor is located below indoor units)
H2	≤ 15 m
H4	≤ 40 m
H5	≤ 15 m
H6	≤ 5 m

**Maximum allowable length after branch**

The pipe length from the first refrigerant branch kit to the indoor unit ≤ 50 m.



**Example:**  $b+g+l \leq 50$  m

If the piping length between the first branch and BP unit or VRV indoor unit is over 20m, it is necessary to increase the gas and liquid piping size between the first branch and BP unit or VRV indoor unit. If the piping diameter of the sized up piping exceeds the diameter of the piping before the first branch kit, then the latter also requires a liquid piping and gas piping size up.

### 9.5 Multi system piping installation

- Front connection  
Remove the front plate knock out holes to connect (see figure below).

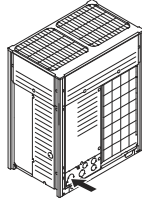

- Bottom connection  
Remove the knock out holes on the bottom frame and route the piping under the bottom frame (see figure below).

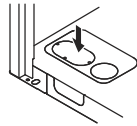

#### 9.5.1 Precautions when connecting piping between outdoor units (multiple outdoor unit system)

- To connect the piping between outdoor units, an optional multi connection piping kit BHFP22P100/151 is always required. When installing the piping, follow the instructions in the installation manual that comes with the kit.
- Only proceed with piping work after considering the limitations on installing listed here and in the chapter "10.2. Connecting the refrigerant piping" always referring to the installation manual delivered with the kit.

#### 9.5.2 Possible installation patterns and configurations

- The piping between the outdoor units must be routed level or slightly upward to avoid the risk of oil retention into the piping.

**Pattern 1**

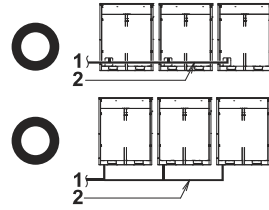

**Pattern 2**

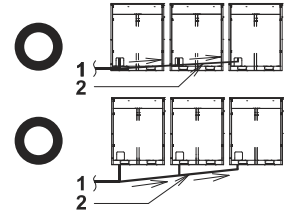

- 1 To indoor unit
- 2 Piping between outdoor units

**Prohibited patterns:** change to pattern 1 or 2.

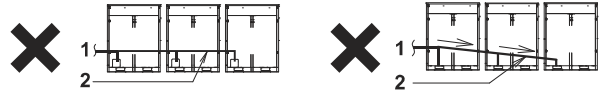

- 1 To indoor unit
- 2 Piping between outdoor units

- To avoid the risk of oil retention to the outmost outdoor unit, always connect the stop valve and the piping between outdoor units as shown in the 4 correct possibilities of the figure below.

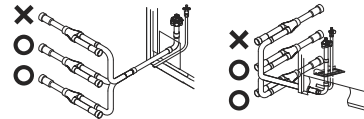

**Prohibited patterns:** change to pattern 1 or 2.

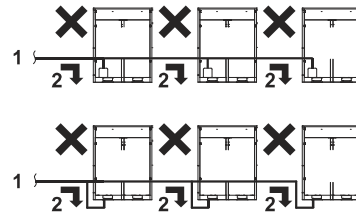

- 1 To indoor unit
- 2 Oil collects to the outmost outdoor unit

**Change to configuration as in figures below**

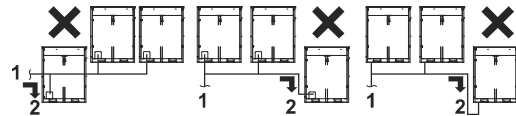

- 1 To indoor unit
- 2 Oil collects to the outmost outdoor unit when the system stops

**Correct configuration**

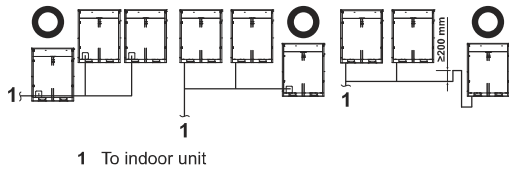

1 To indoor unit

- If the piping length between the outdoor units exceeds 2m, create a rise of 200mm or more in the gas line within a length of 2m from the kit.  
**If ≤ 2 m**

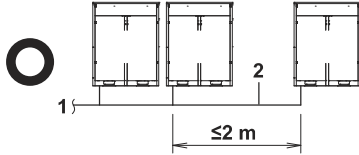

1 To indoor unit  
2 Piping between outdoor units

**If > 2 m**

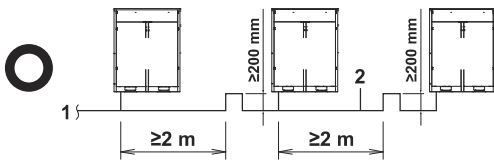

1 To indoor unit  
2 Piping between outdoor units

**10. Precautions on refrigerant piping**

- Do not allow anything other than the designated refrigerant to get mixed into the refrigerant cycle, such as air, nitrogen, etc. If any refrigerant gas leaks while working on the unit, ventilate the room thoroughly right away.
- Use R410A only when adding refrigerant
- Installation tools:  
Make sure to use installation tools (gauge manifold, charge hose, etc.) that are exclusively used for R410A installations to withstand the pressure and to prevent foreign materials (e.g., mineral oils and moisture) from mixing into the system.
- Vacuum pump:
  - Use a 2-stage vacuum pump with a non-return valve.
  - Make sure the pump oil does not flow oppositely into the system while the pump is not working.
  - Use a vacuum pump which can evacuate to -100.7 kPa (5Torr, -755 mm Hg).

**Protection against contamination when installing pipes**

Take measures to prevent foreign materials like moisture and contamination from mixing into the system.

Place	Installation period	Protection method
	More than a month	Pinch the pipe
	Less than a month	
	Regardless of the period	Pinch or tape the pipe

Block all gaps in the holes for passing out piping and wiring using sealing material (field supply) (the capacity of the unit will drop and small animals may enter the machine).

Example: passing piping out through the front.

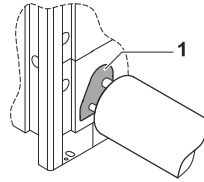

1 Close the areas marked with "1".  
(When the piping is routed from the front panel.)

- Use clean pipes only.
- Hold the pipe end downwards when removing burrs.
- Cover the pipe end when inserting it through a wall so that no dust or dirt enters the pipe.



**NOTICE**

After all the piping has been connected, make sure there is no gas leak. Use nitrogen to perform a gas leak detection.

**10.1 Caution for brazing**

- Make sure to blow through with nitrogen when brazing. Blowing through with nitrogen prevents the creation of large quantities of oxidized film on the inside of the piping. An oxidized film adversely affects valves and compressors in the refrigerating system and prevents proper operation.
- The nitrogen pressure should be set to 0.02MPa (i.e., just enough so it can be felt on the skin) with a pressure-reducing valve.

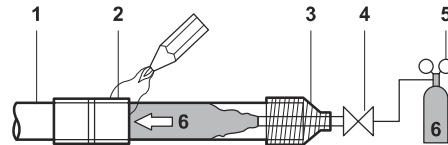

1 Refrigerant piping  
2 Part to be brazed  
3 Taping  
4 Handy valve  
5 Pressure-reducing valve  
6 Nitrogen

Do not use anti-oxidants when brazing the pipe joints. Residue can clog pipes and break equipment:

- Do not use flux when brazing copper-to-copper refrigerant piping. Use phosphor copper brazing filler alloy (BCuP) which does not require flux.
- Flux has an extremely harmful influence on refrigerant piping systems. For instance, if chlorine based flux is used, it will cause pipe corrosion or, in particular, if the flux contains fluorine, it will deteriorate the refrigerant oil.

## 10.2 Connecting the refrigerant piping



### NOTICE

Installation shall be done by an installer, the choice of materials and installation shall comply with the applicable legislation.

### 10.2.1 Decide front or side (bottom) connection

Installation of refrigerant piping is possible as front connection or side connection (when taken out from the bottom) as shown in the figure below.

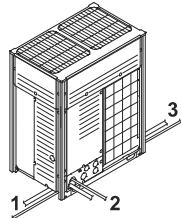

- 1 Left-side connection
- 2 Front connection
- 3 Right-side connection

For side connections, the knockout hole on the bottom plate should be removed:

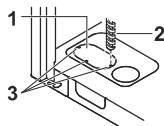

- 1 Large knockout hole
- 2 Drill
- 3 Points for drilling



### NOTICE

Precautions when knocking out knockout holes:

- Be sure to avoid damaging the casing.
- After knocking out the knockout holes, we recommend you remove the burrs and paint the edges and areas around the edges using repair paint to prevent rusting.



- When passing electrical wiring through the knockout holes, wrap the wiring with protective tape to prevent damage as shown above.

### 10.2.2 Remove sealed rubber plug

- When connecting refrigerant piping to an outdoor unit, remove the sealed rubber plug. (Refer to figure shown in right side)
- Sealed rubber plug should be removed using the below procedure.

(Refer to figure shown in right side )

1. Shutoff valve (liquid side - gas side)
2. Service port
3. Sealed rubber plug
4. Procedure 1:  
Confirm the shutoff valve is closed.
5. Procedure 2:  
Connect a charge hose to the service port of the liquid side and gas side shutoff valves and remove the gas from the pipe.

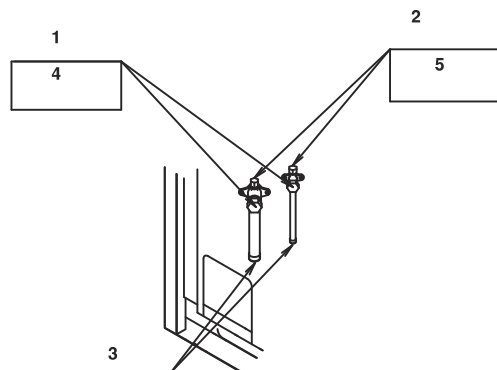

Use the following procedure to remove the sealed rubber plug:

- 1 Remove the valve cover and make sure that the stop valves are fully closed.

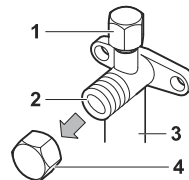

- 1 Service port and service port cover
- 2 Stop valve
- 3 Field piping connection
- 4 Stop valve cover

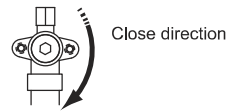

- 2 Connect the vacuuming/recovery unit to service ports of all stop valves.

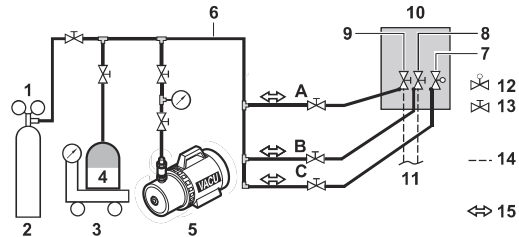

- 1 Pressure reducing valve
- 2 Nitrogen
- 3 Measuring instrument
- 4 Refrigerant R410A tank (siphon system)
- 5 Vacuum pump
- 6 Charge hose
- 7 Refrigerant auto charge valve
- 8 Gas pipe stop valve
- 9 Liquid pipe stop valve
- 10 Outdoor unit
- 11 To indoor unit
- 12 Needle valve
- 13 Stop valve
- 14 Field piping
- 15 Gas flow
- A Valve A
- B Valve B
- C Valve C

- 3 Recover gas and oil from the sealed rubber plug pipe by using a recovery unit.



### CAUTION

Do not vent gases into the atmosphere.

- 4 When all gas and oil is recovered from the sealed rubber plug pipe, disconnect the charge hose and close the service ports.
- 5 Now remove the sealed rubber plug with the help of nose plier/ suitable instrument

### 10.2.3 Connecting refrigerant piping to the outdoor unit



#### INFORMATION

All local inter unit piping are field supplied except the accessory pipes.



#### NOTICE

Precautions when connecting field piping. Add brazing material as shown in the figure.

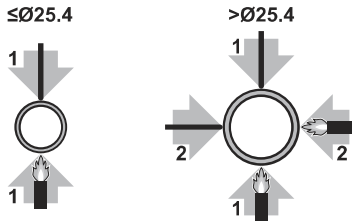

#### NOTICE

- Be sure to use the supplied accessory pipes when carrying out piping work in the field.
- Be sure that the field installed piping does not touch other pipes, the bottom panel or side panel. Especially for the bottom and side connection, be sure to protect the piping with suitable insulation, to prevent it from coming into contact with the casing.

Connection from the stop valves to the field piping can be done by using accessory pipes supplied as accessory.

The connections to the branch kits are the responsibility of the installer (field piping).

### 10.2.4 Branching the refrigerant piping

- For installation of the refrigerant branching kit, refer to the installation manual delivered with the kit.

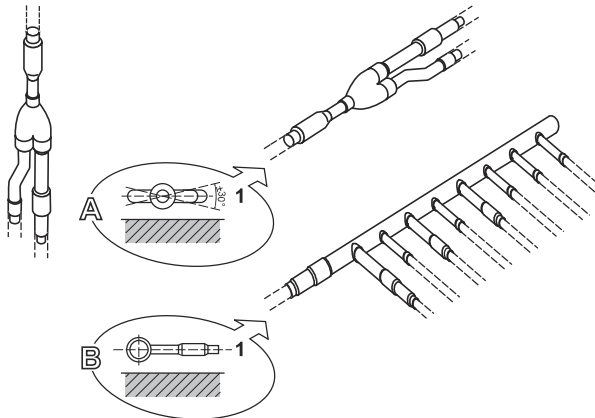

1 Horizontal surface

- 1 Mount the REFNET joint so that it branches either horizontally or vertically.
- 2 Mount the REFNET header so that it branches horizontally.

- Installation of the multi connection piping kit.

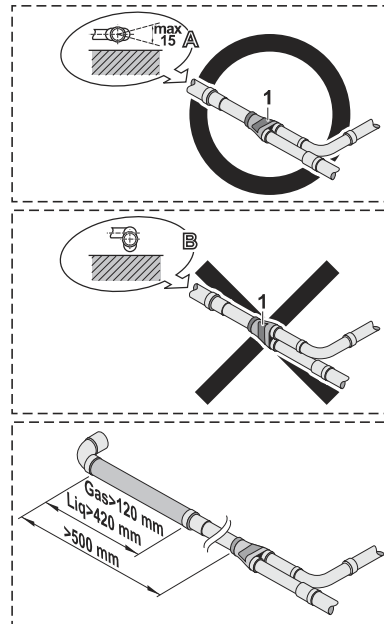

- 1 Install the joints horizontally, so that the caution label (1) attached to the joint comes to the top.
  - Do not tilt the joint more than 15° (see view A).
  - Do not install the joint vertically (see view B).
- 2 Make sure that the total length of the piping connected to the joint is absolute straight for more than 500 mm. Only if a straight field pipe length.
  - Gas field pipe length > 120 mm.
  - Liquid field pipe length > 420 mm.
- 3 Improper installation may lead to malfunction of the outdoor unit.

### 10.3 Guidelines for handling stop valve

#### 10.3.1 Cautions on handling the stop valve

- Make sure to keep both stop valves open during operation.
- The figure below shows the name of each part required in handling the stop valve.
- The stop valve is factory closed.

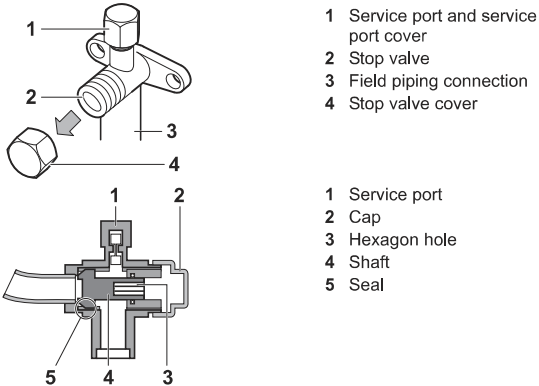

#### 10.3.2 How to use the stop valve

##### Opening the stop valve

- 1 Remove the valve cover.
- 2 Insert a hexagon wrench into the stop valve and turn the stop valve counterclockwise.
- 3 When the stop valve cannot be turned any further, stop turning. The valve is now open.

To fully open the  $\varnothing 19.1$  or  $\varnothing 25.4$  gas line stop valve, turn the hexagonal wrench until a torque between 27 and 33 N•m is achieved. Inadequate torque may cause leakage of refrigerant and breakage of the stop valve cap.

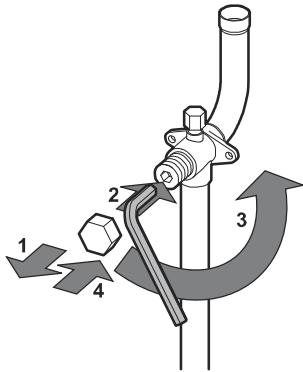

#### NOTICE

Pay attention that mentioned torque range is applicable for opening  $\varnothing 19.1$  and  $\varnothing 25.4$  gas line stop valves only.

##### Closing the stop valve

- 1 Remove the valve cover.
- 2 Insert a hexagon wrench into the stop valve and turn the stop valve clockwise.
- 3 When the stop valve cannot be turned any further, stop turning. The valve is now closed.

Closing direction

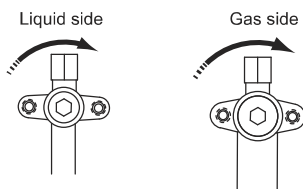

#### 10.3.3 Cautions on handling the stop valve cover

- The stop valve cover is sealed where indicated by the arrow. Take care not to damage it.
- After handling the stop valve, make sure to tighten the stop valve cover securely. For the tightening torque, refer to the table below.
- Check for refrigerant leaks after tightening the stop valve cover.

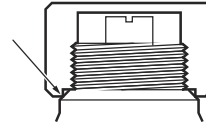

#### 10.3.4 Cautions on handling the service port

- Always use a charge hose equipped with a valve depressor pin, since the service port is a Schrader type valve.
- After handling the service port, make sure to tighten the service port cover securely. For the tightening torque, refer to the table below.
- Check for refrigerant leaks after tightening the service port cover.

#### 10.3.5 Tightening torques

##### [Tightening torque]

The sizes of the stop valves on each model and the tightening torque for each size are listed in the table below.

<Size of stop valve>

	6 • 8 • 10HP type	12HP type	14HP type	16HP type	18HP type	20HP type
Liquid side stop valve	$\varnothing 9.5$ The 12HP type corresponds to the 12.7-diameter onsite piping using the included piping.	$\varnothing 12.7$ The 18~20HP type corresponds to the 15.9-diameter onsite piping using the accessory piping.				
Gas side stop valve	$\varnothing 19.1$ The 10HP type corresponds to the 22.2-diameter onsite piping using the accessory piping.	$\varnothing 25.4$ The 12~18HP type corresponds to the 28.6-diameter onsite piping using the accessory piping.				$\varnothing 28.6$

<Tightening torque>

Stop valve size	Stop Valve Seal Structure	Tighten torque N•m (Turn clockwise to close)			Service port
		Shaft (valve body)		Cap (valve lid)	
$\varnothing 9.5$	Front - Seal Type	$6.0 \pm 0.6$	Hexagonal wrench 4 mm	$15.0 \pm 1.5$	$12.7 \pm 1.2$
$\varnothing 12.7$		$9.0 \pm 0.9$		$20.0 \pm 2.0$	
$\varnothing 15.9$		$15.0 \pm 1.5$	Hexagonal wrench 6 mm	$25.0 \pm 2.5$	
$\varnothing 19.1$	Front - Seal Type + Back - Seal Type	$30.0 \pm 3.0$		Hexagonal wrench 8 mm	
$\varnothing 25.4$			Hexagonal wrench 10 mm		
$\varnothing 28.6$					

## 10.4 Leak test and vacuum drying

It is very important that all refrigerant piping work is done before the units (outdoor or indoor) are powered on.

When the units are powered on, the expansion valves will initialize. This means that they will close. Leak test and vacuum drying of field piping and indoor units is impossible when this happens.

Therefore, there will be explained 2 methods for initial installation, leak test and vacuum drying.

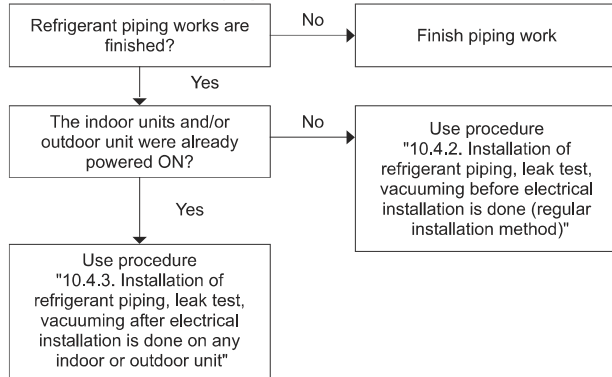

### 10.4.1 General guidelines

- Use a 2-stage vacuum pump with a non-return valve which can evacuate to a gauge pressure of  $-100.7$  kPa (5 Torr absolute,  $-755$  mm Hg).
- Connect the vacuum pump to the service port of all 3 stop valves to increase efficiency (refer to "10.4.4.Setup").



#### NOTICE

Do not purge the air with refrigerants. Use a vacuum pump to evacuate the installation.

### 10.4.2 Installation of refrigerant piping, leak test, vacuuming before electrical installation is done (regular installation method)

When all piping work is complete, it is necessary to:

- Check for any leakages in the refrigerant piping.
- Perform vacuum drying to remove all moisture, air or nitrogen in the refrigerant piping.

If there is a possibility of moisture being present in the refrigerant piping (for example, rainwater may have entered the piping), carry out the vacuum drying procedure below until all moisture has been removed.

All piping inside the unit has been factory tested for leaks.

Only field installed refrigerant piping needs to be checked. Therefore, make sure that all the outdoor unit stop valves are firmly closed before performing leak test or vacuum drying.



#### NOTICE

Make sure that all (field supplied) field piping valves are OPEN (not outdoor unit stop valves!) before you start leak test and vacuuming.

### 10.4.3 Installation of refrigerant piping, leak test, vacuuming after electrical installation is done on any indoor or outdoor unit

Apply outdoor unit setting [2-21]=1 before starting leak test and vacuuming.

This setting will open field expansion valves to guarantee a R410A piping pathway.



#### NOTICE

- Make sure that all (field supplied) field piping valves are OPEN (not outdoor unit stop valves!) before you start leak test and vacuuming.
- Make sure that all indoor units connected to the outdoor unit are powered on.
- Wait until the outdoor unit has finished the initialisation to apply setting [2-21].

When all piping work is complete, it is necessary to:

- Check for any leakages in the refrigerant piping.
- Perform vacuum drying to remove all moisture, air or nitrogen in the refrigerant piping.

If there is a possibility of moisture being present in the refrigerant piping (for example, rainwater may have entered the piping), first carry out the vacuum drying procedure below until all moisture has been removed.

All piping inside the unit has been factory tested for leaks.

Only field installed refrigerant piping needs to be checked. Therefore, make sure that all the stop valves are firmly closed before performing leak test or vacuum drying. (See "10.4.4 Set up" and "10.4 Leak test and vacuum drying")

### 10.4.4 Setup

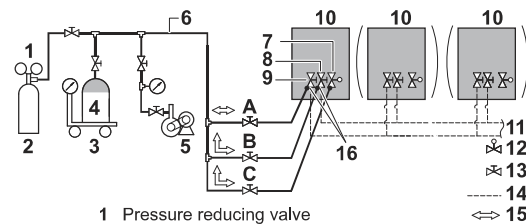

- 1 Pressure reducing valve
- 2 Nitrogen
- 3 Measuring instrument
- 4 Refrigerant R410A tank (siphon system)
- 5 Vacuum pump
- 6 Charge hose
- 7 Refrigerant auto charge valve
- 8 Gas line stop valve
- 9 Liquid line stop valve
- 10 Outdoor unit
- 11 To indoor unit
- 12 Needle valve
- 13 Stop valve
- 14 Field piping
- 15 Gas flow
- 16 Stop valve service port
- A Valve A
- B Valve B
- C Valve C

Which valves?	State of valves
State of the valves A, B, C and the stop valve	Performing the airtightness test and vacuum drying (Gas and Liquid stop valve always close, if not may be cause of refrigerant leakage)
Valve A	Open
Valve B	Open
Valve C	Close
Liquid side stop valve	Close
Gas side stop valve	Close



#### NOTICE

The connections to the indoor units and all indoor units should also be leak and vacuum tested. Keep any possible (field supplied) field piping valves open as well.

Refer to the indoor unit installation manual for more details. Leak test and vacuum drying should be done before the power supply is set to the unit. If not, see also the flow chart earlier described in this chapter (see "10.4.Leak test and vacuum drying").

### 10.4.5 Leak test

The leak test must satisfy the specifications of EN 378-2:

#### 1 Vacuum leak test:

- 1.1 Evacuate the system from the liquid and gas piping to  $-100.7$  kPa (5 Torr) for more than 2 hours.
- 1.2 Once reached, turn off the vacuum pump and check that the pressure does not rise for at least 1 minute.
- 1.3 Should the pressure rise, the system may either contain moisture (see vacuum drying below) or have leaks.

#### 2 Pressure leak test:

- 2.1 Break the vacuum by pressurizing with nitrogen gas to a minimum gauge pressure of 0.2 MPa (2 bar). Never set the gauge pressure higher than the maximum operation pressure of the unit, i.e. 4.0 MPa (40 bar).
- 2.2 Test for leaks by applying a bubble test solution to all piping connections.
- 2.3 Discharge all nitrogen gas.



#### NOTICE

Make sure to use a recommended bubble test solution from your wholesaler. Do not use soap water, which may cause cracking of flare nuts (soap water may contain salt, which absorbs moisture that will freeze when the piping gets cold), and/or lead to corrosion of flared joints (soap water may contain ammonia which causes a corrosive effect between the brass flare nut and the copper flare.)

### 10.4.6 Vacuum drying

To remove all moisture from the system, proceed as follows:

- 1 Evacuate the system for at least 2 hours to a target vacuum of  $-100.7$  kPa.
- 2 Check that, with the vacuum pump turned off, the target vacuum is maintained for at least 1 hour.
- 3 If you fail to reach the target vacuum within 2 hours or maintain the vacuum for 1 hour, the system may contain too much moisture.
- 4 In that case, break the vacuum by pressurizing with nitrogen gas to a gauge pressure of 0.05 MPa (0.5 bar) and repeat steps 1 to 3 until all moisture has been removed.
- 5 The outdoor stop valves can now be opened, and/or additional refrigerant can be charged (see "14.3 Method for adding refrigerant").



#### INFORMATION

After opening the stop valve, it is possible that the pressure in the refrigerant piping does not rise. This might be caused by e.g., the closed state of the expansion valve in the outdoor unit circuit, but does not present any problem for correct operation of the unit.



#### NOTICE

The connections to the indoor units and all indoor units should also be leak and vacuum tested. Keep, if existing, all (field supplied) field valves to the indoor units open as well.

Leak test and vacuum drying should be done before the power supply is set to the unit. If not, see "10.4 Leak test and vacuum drying" for more information.

## 11. Pipe insulation

After finishing the leak test and vacuum drying, the piping must be insulated. Take into account the following points:

- Make sure to insulate the connection piping and refrigerant branch kits entirely.
- Be sure to insulate the liquid and gas piping (for all units).
- Use heat resistant polyethylene foam which can withstand a temperature of 70°C for liquid piping and polyethylene foam which can withstand a temperature of 120°C for gas piping.
- Reinforce the insulation on the refrigerant piping according to the installation environment.

Ambient temperature	Humidity	Minimum thickness
$\leq 30^{\circ}\text{C}$	75% to 80% RH	15 mm
$> 30^{\circ}\text{C}$	$\geq 80\%$ RH	20 mm

- If there is a possibility that condensation on the stop valve might drip down into the indoor unit through gaps in the insulation and piping because the outdoor unit is located higher than the indoor unit, this must be prevented by sealing up the connections. See below figure.

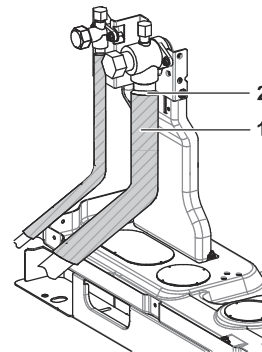

- 1 Insulation material
- 2 Caulking etc.

## 12. Electrical wiring work

### 12.1 Precautions on electrical wiring work



#### WARNING

Electrical installation. All field wiring and components must be installed by a licensed electrician and must comply with the applicable legislation.



#### NOTICE

Electrical wiring work recommendations. To persons in charge of electrical wiring work: Do not operate the unit until the refrigerant piping is complete. "10.4 Leak test and vacuum drying". Running the unit before the piping is ready will break the compressor.



#### DANGER: Electrical shock

See "2. General safety precautions".



### WARNING

- A main switch or other means for disconnection, having a contact separation in all poles, must be incorporated in the fixed wiring in accordance with the applicable legislation.
- Use only copper wires.
- All field wiring must be carried out in accordance with the wiring diagram supplied with the unit and the instructions given below.
- Never squeeze bundled cables and be sure that it does not come in contact with the non-insulated piping and sharp edges. Be sure no external pressure is applied to the terminal connections.
- Power supply wires must be attached securely.
- If the power supply has a missing or wrong N-phase, equipment will break down.
- Be sure to establish an earth. Do not earth the unit to a utility pipe, surge absorber, or telephone earth. Incomplete earth may cause electrical shock.
- Be sure to install an earth leakage protector in accordance with the applicable legislation. Failure to do so may cause electric shock or fire.
- Be sure to use a dedicated power circuit, never use a power supply shared by another appliance.



### WARNING

- When installing the earth leakage protector be sure that it is compatible with the inverter (resistant to high frequency electric noise ) to avoid unnecessary opening of the earth leakage protector.
- As this unit is equipped with an inverter, installing a phase advancing capacitor not only will deteriorate power factor improvement effect, but also may cause a capacitor abnormal heating accident due to high-frequency waves. Therefore, never install a phase advancing capacitor.
- Be sure to install the required fuses or circuit breakers.
- Do not operate until refrigerant piping work is completed. (If operated before completion of the piping work, the compressor may break down.)
- Never remove a thermistor, sensor, etc., when connecting power wiring and transmission wiring. (If operated without thermistor, sensor, etc., the compressor may break down.)

## 12.2 System overview of field wiring

Field wiring consists of power supply (always including earth) and indoor-outdoor communication (= transmission) wiring.

### Examples:

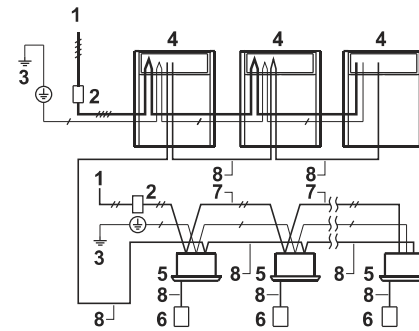

- 1 Field power supply (with earth leakage protector)
- 2 Main switch
- 3 Earth connection
- 4 Outdoor unit
- 5 Indoor unit
- 6 User interface
- 7 Power supply wiring (sheathed cable)
- 8 Transmission wiring (shielded cable) (16V)
- Power supply 3N~50/60 Hz
- Power supply 1~50/60 Hz
- Earth wiring

## 12.3 Opening and closing the electrical component box



### CAUTION

- Do not apply excessive force when opening the electronic component box cover. Excessive force can deform the cover, resulting in entering of water to cause equipment failure.
- When closing the electrical component box cover, make sure that the sealing material on the lower back side of the cover is not caught and bend towards the inside.

### RXYQ6~12

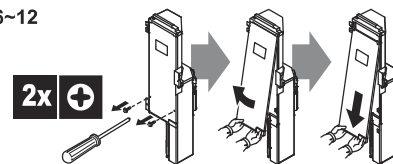

### RXYQ14~20

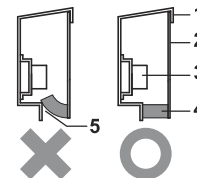
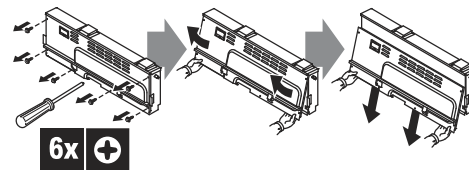

- 1 Electrical component box cover
- 2 Front side
- 3 Power supply terminal block
- 4 Sealing material
- 5 Moisture, dirt and lizards could enter
- X Not allowed
- O Allowed



## 12.4 Requirements

The power supply must be protected with the required safety devices, i.e. a main switch, a slow blow fuse on each phase and an earth leakage protector in accordance with the applicable legislation.

Selection and sizing of the wiring should be done in accordance with the applicable legislation based on the information mentioned in the table below.

### Standard Model

Model	Minimum circuit ampere	Recommended fuses
RXYQ6A	16.1 A	20 A
RXYQ8A	16.1 A	20 A
RXYQ10A	22.0 A	25 A
RXYQ12A	23.0 A	25 A
RXYQ14A	30.0 A	35 A
RXYQ16A	31.0 A	35 A
RXYQ18A	31.0 A	35 A
RXYQ20A	39.0 A	50 A
RXYQ22A	46.0 A	50 A
RXYQ24A	46.0 A	50 A
RXYQ26A	53.0 A	60 A
RXYQ28A	54.0 A	60 A
RXYQ30A	54.0 A	60 A
RXYQ32A	62.0 A	70 A
RXYQ34A	62.0 A	70 A
RXYQ36A	69.0 A	80 A
RXYQ38A	76.0 A	90 A
RXYQ40A	77.0 A	90 A
RXYQ42A	84.0 A	100 A
RXYQ44A	85.0 A	100 A
RXYQ46A	85.0 A	100 A
RXYQ48A	92.0 A	110 A
RXYQ50A	92.0 A	110 A
RXYQ52A	93.0 A	110 A
RXYQ54A	93.0 A	110 A
RXYQ56A	101 A	125 A
RXYQ58A	108 A	125 A
RXYQ60A	116 A	150 A

For all models:  
Phase and frequency: 3N~50 Hz  
Voltage: 380-415 V  
Transmission line section: 0.75~1.25mm<sup>2</sup>, maximum length is 1000 m.

If the total transmission wiring exceeds these limits, it may result in communication error.



### NOTICE

When using residual current operated circuit breakers, be sure to use a high-speed type 200 mA rated residual operating current.

## 12.5 Routing

It is important to keep the power supply and the transmission wiring separated from each other. In order to avoid any electrical interference the distance between both wiring should always be at least 50 mm.

### 12.5.1 Transmission wiring routing

The transmission wiring outside the unit should be wrapped and routed together with the field piping.

Field piping can be routed from front or bottom of the unit (going left or right). Refer to "10.2.Connecting the refrigerant piping".

### Rules for transmission wiring routing

- Be sure to follow the limits below. If the unit-to-unit cables are beyond these limits, it may result in malfunction of transmission:
  - Maximum wiring length: 1000 m.
  - Total wiring length: 2000 m.
  - Maximum inter unit wiring length between outdoor units: 30 m.
  - Maximum number of branches: 16.
  - Maximum number of independent interconnectable systems: 10.
  - Transmission wiring to cool/heat selector : 500 m.
- Up to 16 branches are possible for unit-to-unit cabling. No branching is allowed after branching (see figure below).

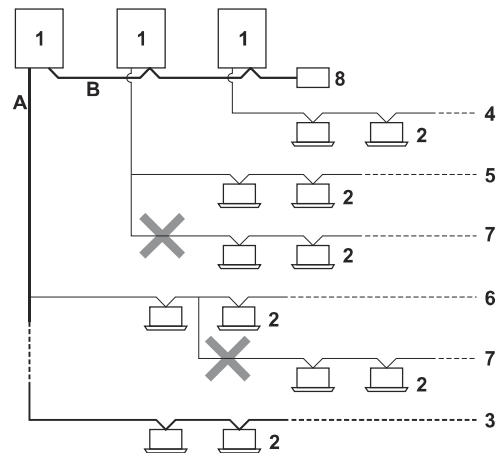

- 1 Outdoor unit
- 2 Indoor unit
- 3 Main line
- 4 Branch line 1
- 5 Branch line 2
- 6 Branch line 3
- 7 No branch is allowed after branch
- 8 Central user interface (etc...)
- A Transmission wiring between outdoor unit and indoor unit(s)
- B Transmission wiring between outdoor units

- Never connect the power supply to transmission wiring terminal block. Otherwise the entire system may break down.
- Never connect 400 V to the terminal block of the transmission wiring. Doing so will break the entire system:
  - The wiring from the indoor units must be connected to the F1/F2 (In-Out) terminals on the PC board in the outdoor unit.
  - After installing the transmission wires inside the unit, wrap them along with the on-site refrigerant pipes using tie wrap and finishing tape, as shown in figure below.

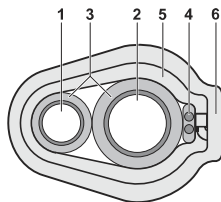

- 1 Liquid pipe
- 2 Gas pipe
- 3 Insulator
- 4 Transmission wiring (F1/F2)
- 5 Tie wrap (3) (Accessories)
- 6 Finishing tape

For the above wiring, always use vinyl cords with 0.75 to 1.25mm<sup>2</sup> shielded or cables (2-core wires).



#### NOTICE

- Be sure to keep the power line and transmission line apart from each other. Transmission wiring and power supply wiring may cross, but may not run parallel.
- Transmission wiring and power supply wiring may not touch internal piping (except INV PCB cooling pipe) in order to avoid wire damage due to high temperature piping.
- Firmly close the lid and arrange the electrical wires so as to prevent the lid or other parts from coming loose.

Transmission wiring routing to the unit and inside the unit.  
Transmission wiring can be routed through the front side only:

- Fix transmission wire with tie wrap (1) (Accessories) to low voltage wiring. See figures below, item 6.
- Possible transmission wire entrance hole (close hole to avoid bugs/dirt from entering). See figures below, item 4.
- Possible transmission wire entrance hole (close hole to avoid bugs/dirt from entering). Fix transmission wiring to pipe insulation with tie wrap (3) (Accessories). See figures below, item 5.
- Inside the electronic component box, the transmission wire should be fixed on several locations with tie wraps to low voltage wiring. See figures below, items 2 and 6.
- Fix transmission wire with tie wrap (2) (Accessories) to heat exchanger fixing plate (hole). See figures below, item 8.

#### RXYQ6~12

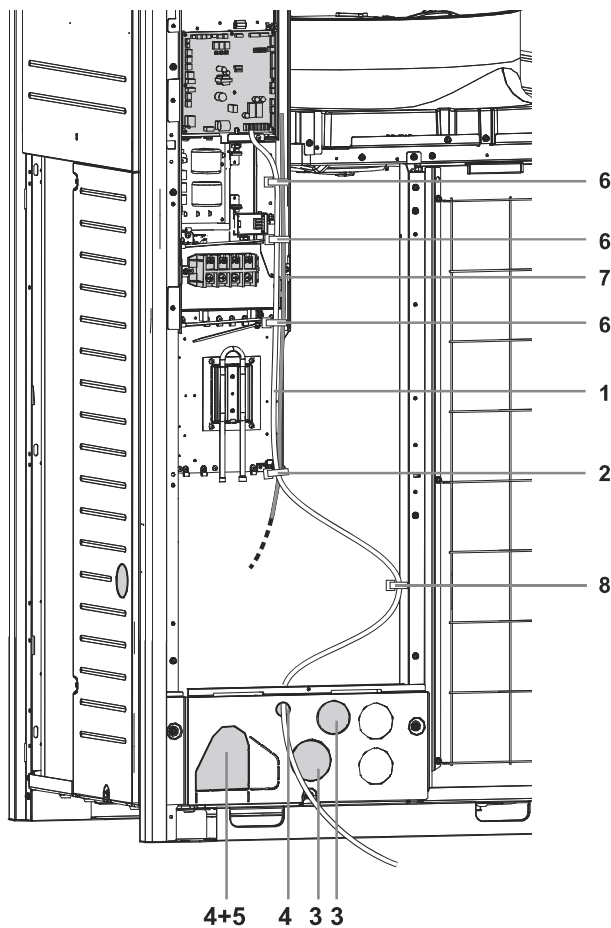

RXYQ14~20

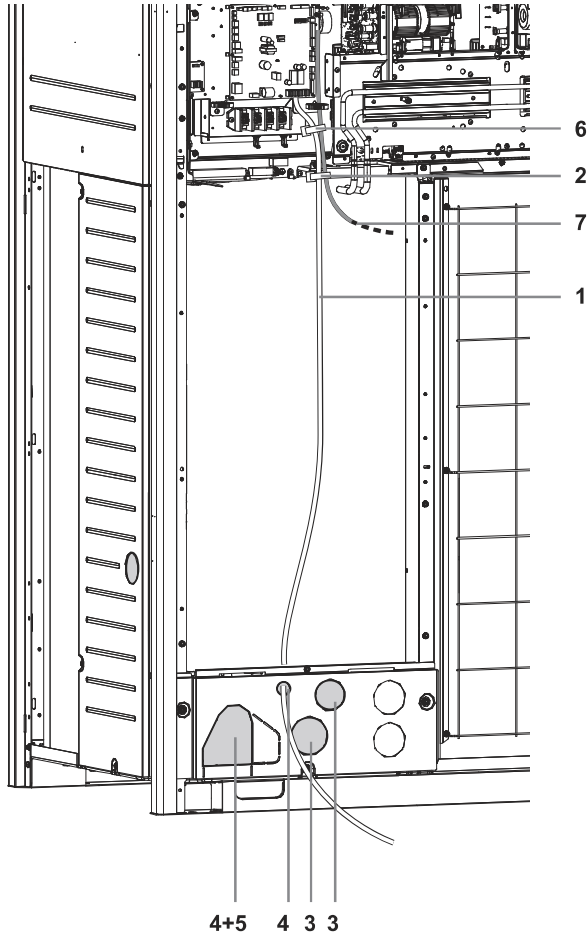

- 1 Transmission wiring
- 2 Fix wiring with tie wrap
- 3 Possible power supply wire entrance hole <sup>(a)</sup>
- 4 Possible transmission wire entrance hole <sup>(a)</sup>
- 5 Possible transmission wire entrance hole. <sup>(a)</sup> Fix wiring to pipe insulation with tie wrap (3) (Accessories)
- 6 Inside the electronic component box, the wiring should be fixed on several locations with tie wraps to the factory mounted low voltage wiring.
- 7 Factory mounted low voltage wiring
- 8 Fix wiring with tie wrap (2) (Accessories) to heat exchanger fixing plate (hole).

(a) Knockout hole has to be removed. Close the hole to avoid small animals or dirt from entering.

12.5.2 Power supply wiring routing

Power supply wire routing to the unit and inside the unit. The power supply wiring can be routed from the front and left side.

- Front side. In order to route the power supply from the front side, the available knockout holes can be used:
  - Fix the power supply cable to the foreseen wire clips with a tie wrap (1) (Accessories). See figures below, item 2.
  - Front plate: possible power supply wire entrance hole (close hole to avoid bugs/dirt from entering). See figures below, item 3.
  - Side plate: possible power supply wire entrance hole (close hole to avoid bugs/dirt from entering). Use conduit. See figures below, item 4.

RXYQ6~12

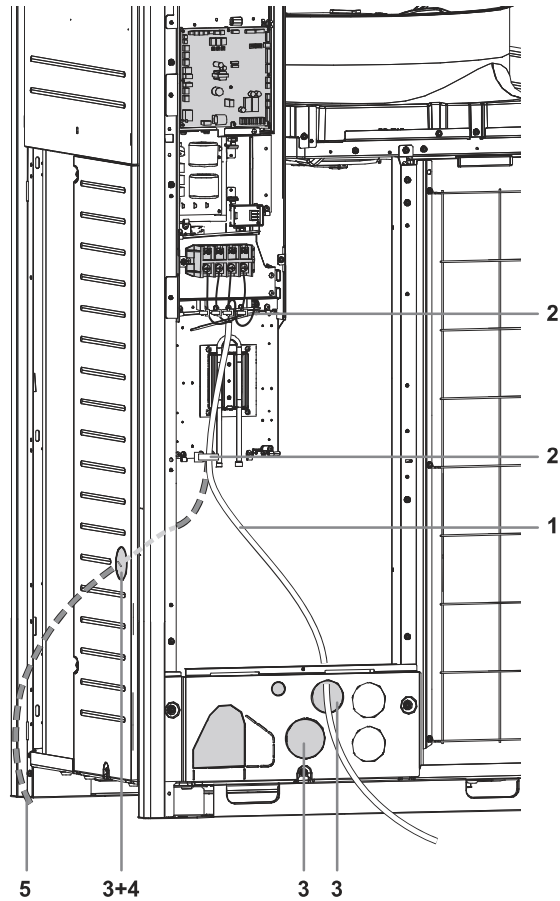

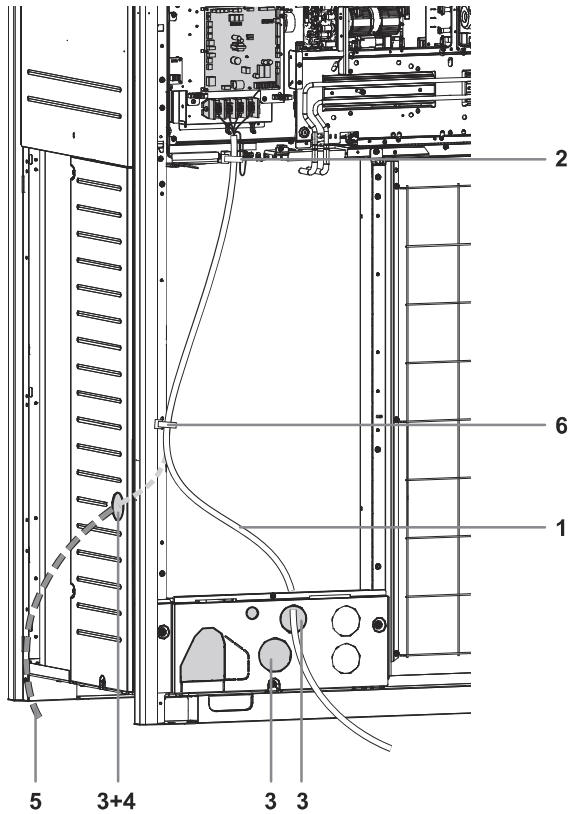

- 1 Power supply wire.
- 2 Fix wiring with tie wrap (1) (Accessories).
- 3+4 Possible power supply wire entrance hole<sup>(a)</sup>.
- 5 Alternative power supply routing.
- 6 Fix wiring with tie wrap (1) (Accessories) to support plate.

(a) Knockout hole has to be removed. Close the hole to avoid small animals or dirt from entering.

**12.5.3 Precautions when knocking out knockout holes**

- To punch a knockout hole, hit on it with a hammer.
- After knocking out the holes, we recommend removing any burrs and paint the edges and areas around the holes using repair paint to prevent rusting.
- When passing electrical wiring through the knockout holes, prevent damage to the wires by wrapping the wiring with protective tape, putting the wires through field supplied protective wire conduits at that location, or install suitable field supplied wire nipples or rubber bushings into the knockout holes.

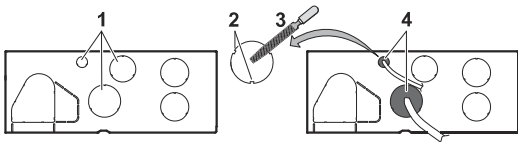

- 1 Knockout hole
- 2 Burr
- 3 Remove burrs
- 4 If there are any possibilities that small animals enter the system through the knockout holes, plug the holes with packing materials (to be prepared on-site)

**12.6 Connection**

This chapter gives an explanation how to route and connect the wiring within the unit.

**12.6.1 Connection of transmission wiring to the system**

**In case of single outdoor unit installation**

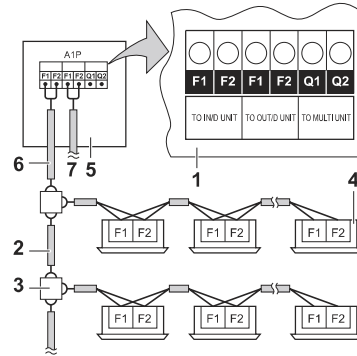

- 1 Outdoor unit PCB board (A1P)
- 2 Use the conductor of shielded wire (2 wire) (no polarity)
- 3 Terminal board (field supply)
- 4 Indoor unit
- 5 Outdoor unit
- 6 Outdoor - indoor unit transmission (F1/F2)
- 7 Outdoor - other system transmission (F1/F2)

**In case of multi outdoor unit installation**

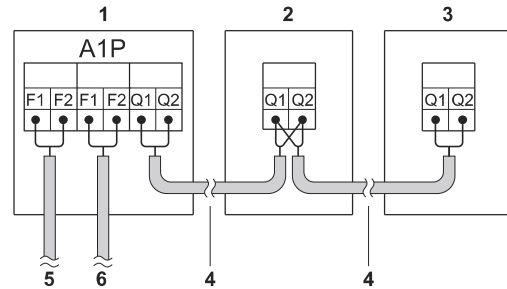

- 1 Unit A (master unit)
- 2 Unit B (slave unit)
- 3 Unit C (slave unit)
- 4 Inter unit transmission wiring (Q1/Q2)
- 5 Outdoor-indoor unit transmission (F1/F2)
- 6 Outdoor-other system transmission (F1/F2)

- The interconnecting wiring between the outdoor units in the same piping system must be connected to the Q1/Q2 (Out Multi) (4) terminals. Connecting the wires to the F1/F2 terminals results in system malfunction.
- The wiring for the other systems must be connected to the F1/F2 (Out-Out) (6) terminals of the PCB board in the outdoor unit to which the interconnecting wiring for the indoor units is connected.
- The base unit is the outdoor unit to which the interconnecting wiring for the indoor units is connected.

## 12.6.2 Connection of wiring to terminals

### Transmission wiring in outdoor unit

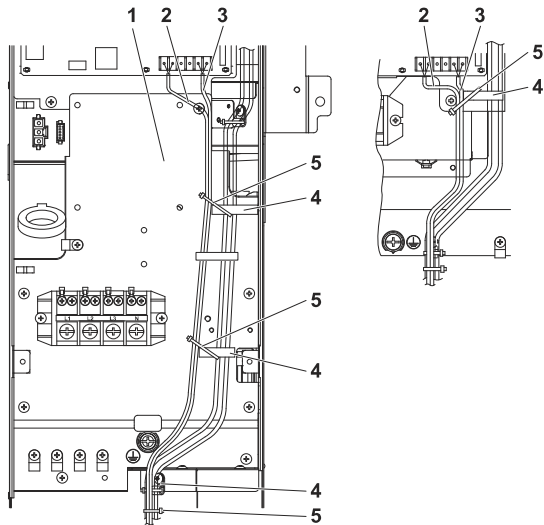

- 1 Fix to the indicated plastic clamps using field supplied clamping material
- 2 Wiring between the units (indoor-outdoor) (F1/F2 left)
- 3 Internal transmission wiring (Q1/Q2)
- 4 Plastic clamp
- 5 Field supplied clamps

Care should be taken for connecting the wires to the terminal block.

See the table below for the tightening torque of the transmission wiring terminals.

Screw size	Tightening torque (N·m)
M3.5 (A1P)	0.88±0.08

- Never connect the power supply to transmission wiring terminal block. Otherwise the entire system may break down.
- Be careful about polarity of the transmission wiring.

### Power supply

The power supply must be clamped to the plastic clamp using field supplied clamp material.

The green and yellow striped wire must be used for earthing only (refer to the figure below).

#### RXYQ6~12

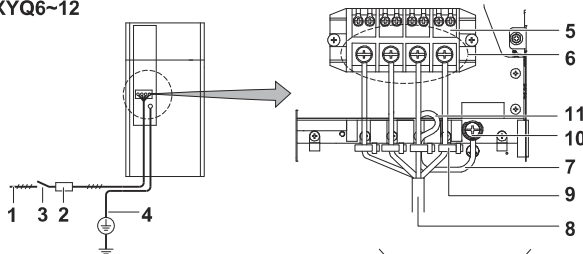

#### RXYQ14~20

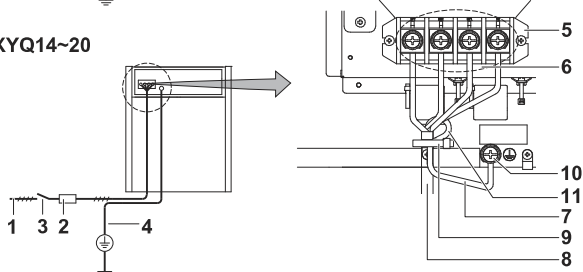

- 1 Power supply (3N~50 Hz, 380~415 V / 3N~60 Hz, 380 V)
- 2 Fuse
- 3 Earth leakage protector
- 4 Earth wire
- 5 Power supply terminal block
- 6 Connect each power wire: RED to L1, WHT to L2, BLK to L3 and BLU to N
- 7 Earth wire (GRN/YLW)
- 8 Clamp the power supply to the plastic clamp using a tie wrap (1) (Accessories) to prevent external force being applied to the terminal.
- 9 Tie wrap (1) (Accessories)
- 10 Cup washer
- 11 When connecting the earth wire, it is recommended to perform curling.



### NOTICE

- When routing earth wires, secure clearance of 25 mm or more away from compressor lead wires. Failure to observe this instruction properly may adversely affect correct operation of other units connected to the same earth.
- When connecting the power supply, the earth connection must be made before the current-carrying connections are established. When disconnecting the power supply, the current-carrying connections must be separated before the earth connection is. The length of the conductors between the power supply stress relief and the terminal block itself must be as such that the current-carrying wires are tautened before the earth wire is in case the power supply is pulled loose from the stress relief.



### NOTICE

Precautions when laying power wiring:

- Do not connect wiring of different thicknesses to the power terminal block (slack in the power wiring may cause abnormal heat).
- Be sure to use crimp-style terminal with insulating sleeves for connections. (See the figure below.)

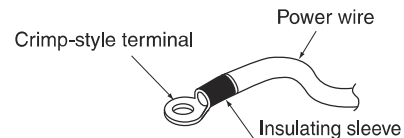

- When connecting wiring which is the same thickness, do as shown in the figure below.



- For wiring, use the designated power wire and connect firmly, then secure to prevent outside pressure being exerted on the terminal board.
- Use an appropriate screwdriver for tightening the terminal screws. A screwdriver with a small head will damage the head and make proper tightening impossible.
- Over-tightening the terminal screws may break them.
- See the table below for tightening torque for the terminal screws.

Tightening torque (N·m)	
M8 (Power terminal block)	6.3±0.6
M8 (Ground)	
M3.5 (Inter-unit wiring terminal block)	0.88±0.08



## NOTICE

Recommendations when connecting the earth wire

Wire it so that it comes through the cut out section of the cup washer. (An improper earth connection may prevent a good earthing from being achieved.) (see the figure below.)

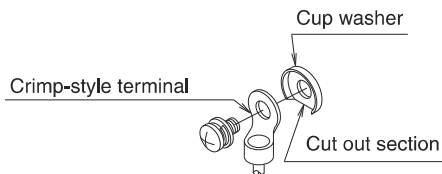

## Connecting the power supply to multiple outdoor units

To connect the power supply for multiple outdoor units to each other, ring tongues have to be used. No bare cable can be used.

The ring washer which is standard provided should be removed in that case.

Attaching both cables to the power supply terminal should be done as indicated.

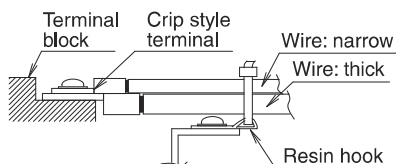

## 13. Making field settings

To continue the configuration of the VRV heat pump system, it is required to give some input to the logic board of the unit. This chapter will describe how manual input is possible by operating the push buttons/DIP switches on the logic board and reading the feedback from the 7 segment displays.

For VRV heat pump system it is alternatively possible to make several commissioning field setting through a personal computer interface (for this, option EKPCCAB1 is required). The installer can prepare the configuration (off-site) on PC and afterwards upload the configuration to the system.

### 13.1 Accessing the push buttons on the logic board

It is not required to open the complete electronic component box to access the push buttons on the logic board and read out the 7 segment display(s).

To access you can remove the front plate (see figure). Now you can open the inspection cover of the electrical component box front plate (see figure). You can see the three push buttons and the three 7 segment displays and DIP switches.

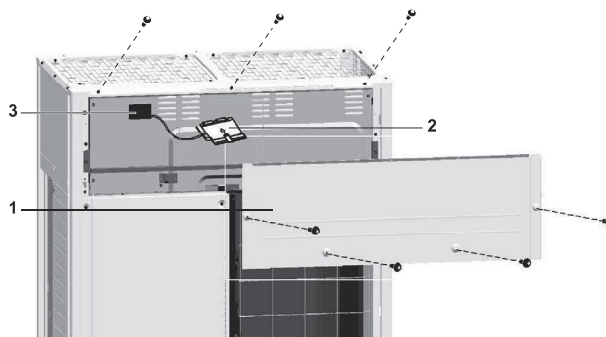

- 1 Front plate
- 2 Inspection cover
- 3 Main PCB with 3 seven segment display and 3 push buttons

Operate the switches and push buttons with an insulated stick (such as a closed ball-point pen) to avoid touching of live parts.



Location of the 7 segment displays, buttons and DIP switches:

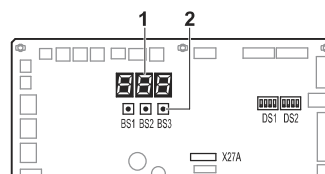

- BS1 MODE** for changing the set mode
- BS2 SET** for field setting
- BS3 RETURN** for field setting
- DS1, DS2** DIP switches
- 1 7 segment displays (3x)
- 2 Push buttons

Segment display indications:



## 13.2 Operating the push buttons and DIP switches on the logic board

### 13.2.1 Operating the push buttons

By operating the push buttons it is possible to:

- Perform special actions (test run, etc).
- Perform field settings (demand operation, low noise, etc).

Below procedure explains how to operate the push buttons to reach the required mode in the menu, select the correct setting and modify the value of the setting. This procedure can be used any time special settings and regular field setting are discussed in this manual.

Setting definition: [A-B]=C; A=mode; B=setting; C=setting value. A, B and C are numerical values for field settings. Parameter C has to be defined. It can be a chosen from a set (0, 1, 2, 3, 4, 5, ...) or regarded as an ON/OFF (1 or 0) depending on the contents. This is informed when the field setting is explained.



## INFORMATION

During special operation (e.g., test run, etc.) or when a malfunction happened, information will contain letters and numerical values.

## Functions of the push button switches which are located on the outdoor PCB (A1P)

Turn on the power supply of the outdoor unit and all indoor units. When the communication between indoor units and outdoor unit(s) is established and normal, the segment indication state will be as below (default situation when shipped from factory).

When turning on the power supply: flashing as indicated. First checks on power supply are executed (1~2 min).



When no trouble occurs: lighted as indicated (8~10 min).



Ready for operation: blank display indication as indicated.



When above situation cannot be confirmed after 12 min, the malfunction code can be checked on the indoor unit user interface and the outdoor unit segment display. Solve the malfunction code accordingly. The communication wiring should be checked at first.



### INFORMATION

Be sure to turn the power on at least 6 hours before operation in order to have power running to the crank case heater.

## Accessing modes

BS1 is used to change the mode you want to access.

### • Access mode 1

Push BS1 one time. Segment indication changes to:



### • Access mode 2

Push BS1 for at least 5 seconds. Segment indication changes to:



### INFORMATION

If you get confused in the middle of the process, push BS1. Then it returns to idle situation (no indication on segment displays: blank)

## Mode 1

Mode 1 is used to set basic settings and to monitor the status of the unit.

- Changing and access the setting in mode 1:  
Once mode1 is selected (push BS1 1 time), you can select the wanted setting. It is done by pushing BS2. Accessing the selected setting's value is done by pushing BS3 1 time.
- To quit and return to the initial status, press BS1.

### Example:

Checking the content of parameter [1-10] (to know how many indoor units are connected to the system).

[A-B]=C in this case defined as: A=1; B=10; C=the value we want to know/monitor:

- Make sure the segment indication is as during normal operation (default situation when shipped from factory).
- Push BS1 1 time; result segment display:



Result: mode 1 is accessed.

- Push BS2 10 times; result segment display:



Result: mode 1 setting 10 is addressed.

- Push BS3 1 time; the value which is returned (depending on the actual field situation), is the amount of indoor units which are connected to the system.  
Result: mode1 setting 10 is addressed and selected, return value is monitored information
- To leave the monitoring function, push BS1 1 time, you will return to the default situation when shipped from factory.

## Mode 2

Mode2 is used to set field settings of the outdoor unit and system.

- Changing and access the setting in mode 2:  
Once mode 2 is selected (push BS1 for more than 5 seconds), you can select the wanted setting. It is done by pushing BS2. Accessing the selected setting's value is done by pushing BS3 1 time.
- To quit and return to the initial status, press BS1.
- Changing the value of the selected setting in mode 2:
  - Once mode 2 is selected (push BS1 for more than 5 seconds) you can select the wanted setting. It is done by pushing BS2.
  - Accessing the selected setting's value is done by pushing BS3 1 time.
  - Now BS2 is used to select the required value of the selected setting.
  - When the required value is selected, you can define the change of value by pushing BS3 1 time.
  - Press BS3 again to start operation according to the chosen value.

### Example:

Checking the content of parameter [2-18] (to define the high static pressure setting of the outdoor unit's fan).

[A-B]=C in this case defined as: A=2; B=18; C=the value we want to know/change

- Make sure the segment indication is as during normal operation (default situation when shipped from factory).
- Push BS1 for over 5 seconds; result segment display:



Result: mode 2 is accessed.

- Push BS2 18 times; result segment display:



Result: mode 2 setting 18 is addressed.

- Push BS3 1 time; the value which is returned (depending on the actual field situation), is the status of the setting. In the case of [2-18], default value is "0", which means the function is not active.  
Result: mode2 setting 18 is addressed and selected, return value is the current setting situation.
- To change the value of the setting, push BS2 till the required value appears on the segment indication. When achieved, define the setting value by pushing BS3 1 time. To start operation according to the chosen setting, confirm again by pushing BS3.
- To leave the monitoring function, push BS1 2 times, you will return to the default situation when shipped from factory.

### 13.2.2 Operating the DIP switches

By operating the DIP switches it is possible to:

What to do with DIP switch DS1	
1	OFF=not installed=factory setting
2-4	NOT USED DO NOT CHANGE THE FACTORY SETTING
What to do with DIP switch DS2	
1-4	NOT USED DO NOT CHANGE THE FACTORY SETTING

## 14. Charging refrigerant

### 14.1 Precautions



#### NOTICE

- Refrigerant cannot be charged until field wiring has been completed.
- Refrigerant may only be charged after performing the leak test and the vacuum drying.
- When charging a system, care shall be taken that its maximum permissible charge is never exceeded, in view of the danger of liquid hammer.
- Charging with an unsuitable substance may cause explosions and accidents, so always ensure that the appropriate refrigerant R410A is charged.
- Refrigerant containers shall be opened slowly.
- Always use protective gloves and protect your eyes when charging refrigerant.
- When the refrigerant system is to be opened, refrigerant must be treated according to the applicable legislation.



#### DANGER: Electrical shock

See "2. General safety precautions".

- To avoid compressor breakdown. Do not charge the refrigerant more than the specified amount.
- This outdoor unit is factory charged with refrigerant and depending on pipe sizes and pipe lengths some systems require additional charging of refrigerant.
- In case re-charge is required, refer to the name plate of the unit. It states the type of refrigerant and necessary amount.

## 14.2 Calculating the additional refrigerant charge

### How to calculate the additional refrigerant to be charged

Additional refrigerant to be charged=R (kg). R should be rounded off in units of 0.1 kg.

$$R=[(X_1 @ \text{Ø}22.2) \times 0.36+(X_2 @ \text{Ø}19.1) \times 0.26+(X_3 @ \text{Ø}15.9) \times 0.17+(X_4 @ \text{Ø}12.7) \times 0.11+(X_5 @ \text{Ø}9.5) \times 0.057+(X_6 @ \text{Ø}6.4) \times 0.022 ]+A$$

$X_{1...6}$  =Total length (m) of liquid piping size at Øa

A parameter (kg)	Total indoor unit capacity CR <sup>(a)</sup>	HP			
		6~8	10~12	14~16	18~20
Piping length≤30 m	50%≤CR≤105%	0			0.5
	105%<CR≤130%	0.5			1.0
	130%<CR≤160%	0.5			1.3
	160%<CR≤200%	0.5	0.7	1.0	1.5
Piping length>30 m	50%≤CR≤70%	0			0.5
	70%<CR≤85%	0.3	0.5		1.0
	85%<CR≤105%	0.7	1.0		1.5
	105%<CR≤130%	1.2	1.5		2.0
	130%<CR≤160%	1.2	1.5		2,3
	160%<CR≤200%	1.2	1.7	2.0	2.5

(a) CR=Connection ratio.

Piping length is considered the distance from the outdoor unit to the farthest indoor unit.

In case of a multi-outdoor-unit system, add the sum of the individual outdoor unit charge factors.

When using metric piping, please take into account following table concerning the weight factor to be allocated. It should be substituted in the formula for R.

Inch piping	
size (Ø) (mm)	Weight factor
Ø6.4 (1/4")	0.022
Ø9.5 (3/8")	0.057
Ø12.7 (1/2")	0.11
Ø15.9 (5/8")	0.17
Ø19.1 (3/4")	0.26
Ø22.2 (7/8")	0.36

When selecting indoor unit, following table with connection ratio limitation has to be respected. More detailed information can be found in technical engineering data.

Used indoor units	Total capacity CR <sup>(a)</sup>	Allowable capacity connection ratio	
		VRV	RA
VRV	50~200%	50~200%	—
VRV + RA	80~130%	0~130%	0~130%
RA	80~130%	—	80~130%

(a) Connection ratio.



## 14.3 Method for adding refrigerant

### 14.3.1 Flow chart

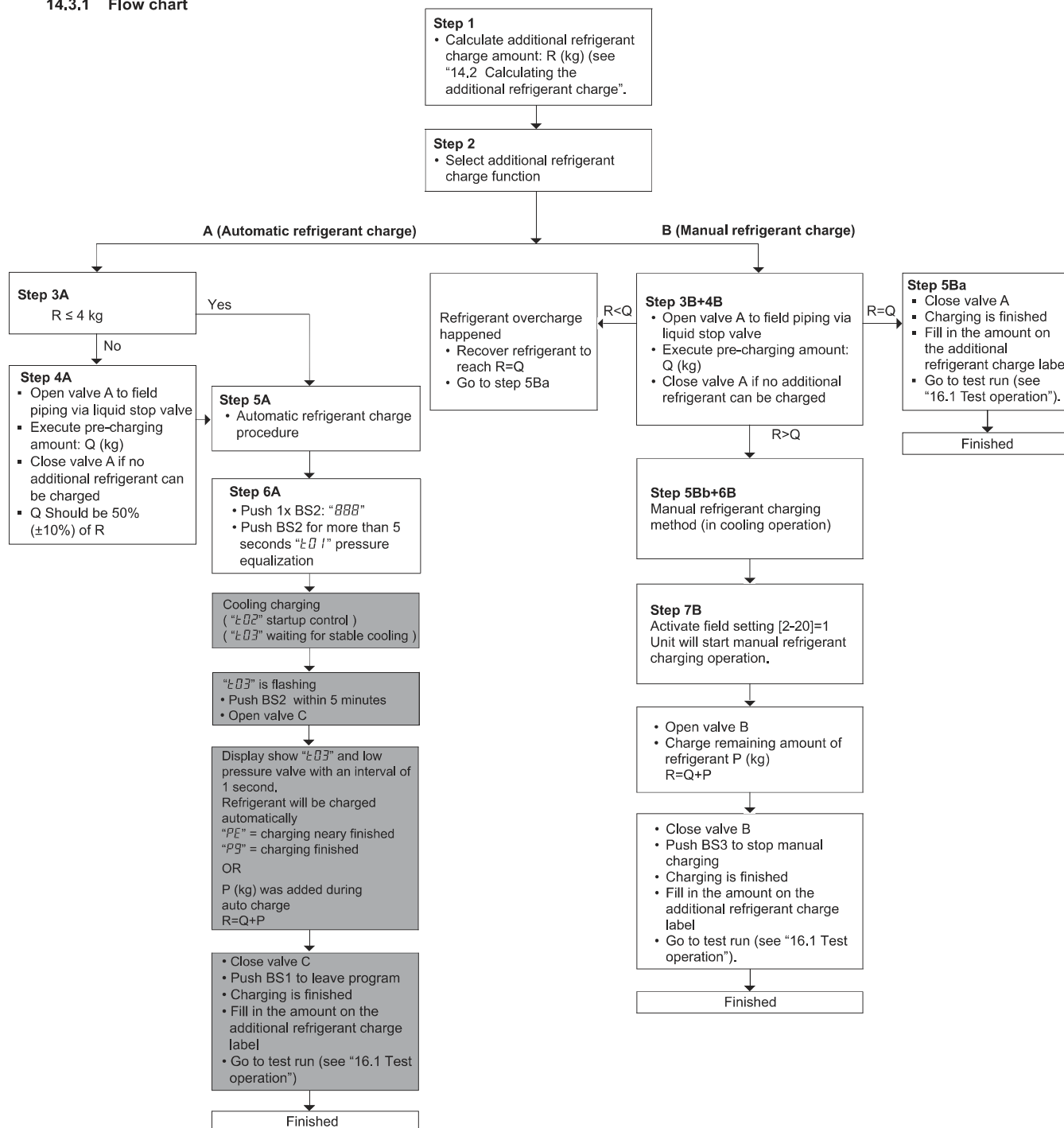

See figure "Location of valves" ; for more information refer to the text in this chapter.

Be sure to charge the specified amount of refrigerant in liquid state. Since this refrigerant is a mixed refrigerant, adding it in gas form may cause the refrigerant composition to change, preventing normal operation.

- Before charging, check whether the refrigerant cylinder is equipped with a siphon tube or not.

Charge the liquid refrigerant with the cylinder in upright position.



Charge the liquid refrigerant with the cylinder in upside-down position.



- Be sure to use tools exclusively for R410A to ensure required pressure resistance and to prevent foreign materials from mixing into the system.



#### NOTICE

Charging with an unsuitable substance may cause explosions and accidents, so always make sure that the appropriate refrigerant (R410A) is charged. Refrigerant containers must be opened slowly.



## CAUTION

- If charge refrigerant without automatic charging procedure, refrigerant amount may be over the permissible quantity and result to liquid hammer.
- Always use protective gloves and protect your eyes when charging refrigerant.
- When the refrigerant charging procedure is done or when pausing, close the valve of the refrigerant tank immediately. If the tank is left with the valve open, the amount of refrigerant which is properly charged may get off point. More refrigerant may be charged by any remaining pressure after the unit has stopped.



## NOTICE

- If the power of some units is turned off, the charging procedure cannot be finished properly.
- In case of a multiple outdoor system, turn on the power of all outdoor units.
- Make sure to turn ON the power 6 hours before starting the operation. This is necessary to warm the crankcase by the electric heater.
- If operation is performed within 12 minutes after the indoor and outdoor units are turned on, the compressor will not operate before the communication is established in a correct way between outdoor unit(s) and indoor units.
- Before starting charging procedures, check if the segment display indication of the outdoor unit A1P PCB is as normal (see "Functions of the push button switches which are located on the outdoor PCB (A1P)"). If a malfunction code is present, see "16.2. Malfunction code list".
- Make sure all connected indoor units are recognised
- Close the front panel before any refrigerant charge operation is executed. Without the front panel attached the unit cannot judge correctly whether it is operating properly or not.



## NOTICE

In case of maintenance and the system (outdoor unit+field piping+indoor units) does not contain any refrigerant any more (e.g., after refrigerant reclaim operation), the unit has to be charged with its original amount of refrigerant (refer to the nameplate on the unit) by pre-charging before the automatic charging function can be started.

### 14.3.2 Charging method

As explained during vacuum drying method, once vacuum drying is finished, additional refrigerant charging can start.

There are two methods to charge additional refrigerant. Use the selected method following the described procedure below.

- Adding refrigerant by using the automatic refrigerant charging function.  
See "A. Adding refrigerant by using the automatic charging function". This method uses an automated method for charging refrigerant.
- Adding refrigerant by using the manual refrigerant charging function.  
See "B. Adding refrigerant by using the manual charging function". This method uses a manual method for charging refrigerant.

A flow chart is available which gives an overview of the possibilities and actions to be taken (see "14.3.1 Flow chart").

Follow the steps as described below and take into account whether you want to use the automatic charge function or not.

- 1 Calculate the additional amount of refrigerant to be added using the formula mentioned in "14.2 Calculating the additional refrigerant charge".
- 2 Select additional refrigerant charge function **A** or **B**.

## A Perform Automatic refrigerant charge function.

- 3A Check the additional refrigerant amount R (kg)
  - Total additional refrigerant is 4 kg or less ( $R \leq 4$  kg) perform the automatic refrigerant charging procedure as explained in step 5A.
  - Total additional refrigerant amount more than 4 kg ( $R > 4$  kg) perform the pre-charging procedure as explained in step 4A.
- 4A The first 50% ( $\pm 10\%$ ) of additional refrigerant can be charged without outdoor unit operation.
  - Pre-charging can be done without compressor running by connecting the refrigerant bottle only to the liquid stop valve service port (open valve A). Make sure that the stop valves are closed (valve C and valve B+gas line stop valve)

### Location of valves

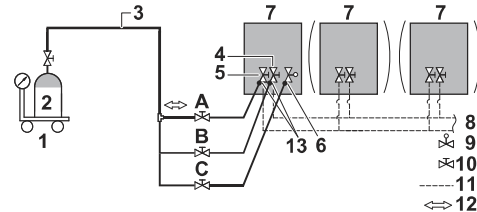

- 1 Measuring instrument
- 2 Refrigerant R410A tank (siphon system)
- 3 Charge hose
- 4 Gas line stop valve
- 5 Liquid line stop valve
- 6 Refrigerant auto charge valve
- 7 Outdoor unit
- 8 To indoor unit
- 9 Needle valve
- 10 Stop valve
- 11 Field piping
- 12 Gas flow
- 13 Stop valve service port
- A Valve A
- B Valve B
- C Valve C

- After pre-charging, perform the refrigerant charge operation as shown below and charge the remaining refrigerant of the additional charging amount through valve C. Open the liquid and gas side stop valves. Valves A and B and C must remain closed !



## INFORMATION

For a multi outdoor unit system, it is not required to connect all charge ports to a refrigerant tank.

The refrigerant will be charged with 22 kg in 1 hour time at an outdoor temperature of 30°C DB or with 6 kg at an outdoor temperature of 0°C DB.

If you need to speed up in case of a multiple outdoor system, connect the refrigerant tanks to each outdoor unit.



## NOTICE

- The unit's internal piping is already factory charged with refrigerant, so be careful when connecting the charge hose.
- After adding the refrigerant, do not forget to close the lid of the refrigerant charging port. The tightening torque for the lid is 11.5 to 13.9 N·m.
- In order to ensure uniform refrigerant distribution, it may take the compressor  $\pm 10$  minutes to start up after the unit has started operation. This is not a malfunction.

## 5A Adding refrigerant by using the automatic charging function



## INFORMATION

The automatic refrigerant charging has limits as described below.

- Outdoor temperature: 0°C DB~43°C DB.
- Indoor temperature: 10°C DB~32°C DB.

- 6A** The remaining additional refrigerant charge can be charged by operating the outdoor unit depending on the ambient limitation conditions (see previously page).

*Procedure*

- Idle (default) screen is shown.
- Push BS2 once, indication "888".
- Push BS2 for more than 5 seconds, wait while the unit is preparing for operation. Segment display indication: "L01" (pressure control is executed):
  - Cooling operation is started: indication "L02" till "L03" will be displayed (start up control; waiting stable cooling operation).
- When "L03" starts flashing (ready for charging), push BS2 within 5 minutes. Open valve C. If BS2 is not pushed within 5 minutes, a malfunction code will appear:
  - Cooling operation: malfunction code "P2" will appear. Push BS3 to restart the procedure.

*Cooling (middle segment indicates "0")*

Automatic charging will continue, the segment indication shows the current low pressure value and the status indication "L03" intermittent.

If the segment indication/user interface of indoor unit shows "PE" code, charging is almost finished. When the unit stops operating, close valve C and check whether the segment indication/user interface of indoor unit shows "P9".

This indicates the automatic charging in cooling program was finished successfully.



**INFORMATION**

When the charging amount is little, the "PE" code may not be displayed, but instead the "P9" code will be displayed immediately.



**INFORMATION**

- When a malfunction is detected during the procedure (e.g. in case of closed stop valve), a malfunction code will be displayed. In that case, refer to "16.2 Malfunction code list" and solve the malfunction accordingly. Resetting the malfunction can be done by pushing BS3. The procedure can be restarted from 6A).
- Aborting the automatic refrigerant charge is possible by pushing BS1. The unit will stop and return to idle condition.

*Information which may occur during additional refrigerant charging procedures:*

*PB:* Indoor unit freeze up prevention

**Action:** Close valve C . Reset malfunction by pushing BS1. Retry auto charge procedure.

*P2:* Abnormal low pressure drop

**Action:** Close valve C . Reset malfunction by pushing BS1. Check following items before retry auto charge procedure:

- Check if the gas side stop valve is opened correctly.
- Check if the valve of the refrigerant cylinder is opened.
- Check if the air inlet and outlet of the indoor units are not obstructed.

Other malfunction code: close valve C . Confirm the malfunction code and take corresponding action, "16.2 Malfunction code list".

- B** Perform Manual refrigerant charge function.

- 3B** The first 10 kg of additional refrigerant can be charged without outdoor unit operation.

If the additional refrigerant amount is smaller than 10 kg (R < 10kg), perform the pre-charging procedure as explained in step 4B and 5Ba below.

If the additional refrigerant charge is larger than 10 kg (R ≥ 10kg), perform step 4B till the end of the procedure 7B.

- 4B** Pre-charging can be done without compressor running by connecting the refrigerant bottle only to the liquid stop valve service port (open valve A). Make sure that the stop valves are closed (valve B+liquid line stop valve+gas line stop valve)

**Location of valves**

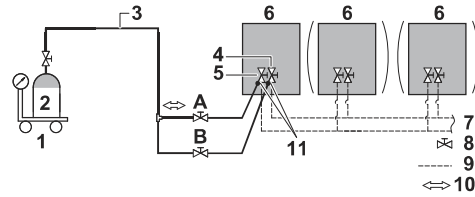

- 1 Measuring instrument
- 2 Refrigerant R410A tank (siphon system)
- 3 Charge hose
- 4 Gas line stop valve
- 5 Liquid line stop valve
- 6 Outdoor unit
- 7 To indoor unit
- 8 Stop valve
- 9 Field piping
- 10 Gas flow
- 11 Stop valve service port
- A Valve A
- B Valve B

- 5Ba** If the calculated additional refrigerant amount is reached by above pre-charging procedure, close valve A. Refrigerant charging is finished.

- 5Bb** If the total amount of refrigerant could not be charged by pre-charging, then close valve A and go to step 6B. Follow step 7B depending on the chosen charging method.



**INFORMATION**

If the total additional refrigerant amount was reached in step 5B (by pre-charging only), record the amount of refrigerant that was added on the additional refrigerant charge label provided with the unit and attach it on the back side of the front panel.

Perform the test procedure as described in "16.1 Test operation".

- 6B** After pre-charging, perform the refrigerant charge operation as shown below and charge the remaining refrigerant of the additional charging amount through valve B. Open the liquid and gas side stop valves. Valves A and B must remain closed!



**INFORMATION**

For a multi outdoor unit system, it is not required to connect all charge ports to a refrigerant tank.

The refrigerant will be charged with ±22 kg in 1 hour time at an outdoor temperature of 30°C DB or with ±6 kg at an outdoor temperature of 0°C DB.

If you need to speed up in case of a multiple outdoor system, connect the refrigerant tanks to each outdoor unit.



**NOTICE**

- The unit's internal piping is already factory charged with refrigerant, so be careful when connecting the charge hose.
- After adding the refrigerant, do not forget to close the lid of the refrigerant charging port. The tightening torque for the lid is 12.7±1.2 N·m.
- In order to ensure uniform refrigerant distribution, it may take the compressor ±10 minutes to start up after the unit has started operation. This is not a malfunction.

## Adding refrigerant by using the manual charging function

**7B** The remaining additional refrigerant charge can be charged by operating the outdoor unit by means of the manual refrigerant charge operation mode:

- Turn on the power of the indoor units and outdoor unit.
- Take all the precautions mentioned in "start-up and configuration" into account.
- Activate outdoor unit setting [2-20]=1 to start manual refrigerant charge mode.  
**Result:** The unit will start operation, Valve B can be opened. Charging of remaining additional refrigerant can be done. When the remaining calculated additional refrigerant amount is added, close valve B and push BS3 to stop the manual refrigerant charging procedure.



### INFORMATION

- The manual refrigerant charge operation will automatically stop within 30 minutes. If charging is not completed after 30 minutes, perform the additional refrigerant charging operation again.
- When a malfunction is detected during the procedure (e.g., in case of closed stop valve), a malfunction code will be displayed. In that case, refer to "16.2 Malfunction code list" and solve the malfunction accordingly. Resetting the malfunction can be done by pushing BS3. The procedure can be restarted from **7B**.
- Aborting the manual refrigerant charge is possible by pushing BS3. The unit will stop and return to idle condition.

### 14.3.3 Checks after adding refrigerant

- Are the stop valves for liquid and gas open?
- Is the amount of refrigerant, that has been added, recorded on the refrigerant charge label?



### NOTICE

Make sure to open all stop valves after (pre-) charging the refrigerant.

Operating with the stop valves closed will damage the compressor.

## 15. Monitoring function and field settings

The operation of the outdoor unit can further be defined by changing some field settings. Next to making field settings it is also possible to confirm the current operation parameters of the unit.

Below relevant Monitoring mode (mode 1) and Field setting mode (mode 2) settings are explained in detail. How to access them, how to change the value of the settings and how to confirm them is explained in "13. Making field settings". In that chapter, an example is given on how to make a setting. It is advised to check this procedure before accessing, checking and changing below settings.

Once the default situation of the segment indication is confirmed (see "13. Making field settings"), the mode 1 and mode 2 can be accessed.

Making settings is done via the master outdoor unit.

### 15.1 Mode 1

Mode 1 can be used to monitor the current situation of the outdoor unit. Some field setting contents can be monitored as well.

Below the settings in mode 1 are explained.

[1-0]= Shows whether the unit you check is a master, slave 1 or slave 2 unit

- No indication=undefined situation
- 0=outdoor unit is master unit
- 1=outdoor unit is slave 1 unit
- 2=outdoor unit is slave 2 unit

Master, slave 1 and slave 2 indications are relevant in multiple outdoor unit system configurations. The allocation of which outdoor unit is master, slave 1 or slave 2 are decided by the unit's logic.

**The master unit should be used to input field settings in mode 2.**

[1-1]= Shows the status of low noise operation

- 1=unit is currently operating under low noise restrictions
- 0= unit is currently not operating under low noise restrictions

Low noise operation reduces the sound generated by the unit compared to nominal operating conditions.

Low noise operation can be set in mode 2. There are two methods to activate low noise operation of the outdoor unit system.

The first method is to enable an automatic low noise operation during night time by field setting. The unit will operate at the selected low noise level during the selected time frames.

The second method is to enable low noise operation based on an external input. For this operation an optional accessory is required.

[1-2]= Shows the status of power consumption limitation operation

- 1=unit is currently operating under power consumption limitation
- 0=unit is currently not operating under power consumption limitations

Power consumption limitation reduces the power consumption of the unit compared to nominal operating conditions.

Power consumption limitation can be set in mode 2. There are two methods to activate power consumption limitation of the outdoor unit system.

The first method is to enable a forced power consumption limitation by field setting. The unit will always operate at the selected power consumption limitation.

The second method is to enable power consumption limitation based on an external input. For this operation an optional accessory is required.

[1-5]= Shows the current T<sub>e</sub> target parameter position.  
Refer to "15.3 Energy saving and optimum operation" for more details about the contents of this value.

[1-6]= Shows the current T<sub>e</sub> target parameter position.  
Refer to "15.3 Energy saving and optimum operation" for more details about the contents of this value.

[1-10]= Shows the total number of connected indoor units  
It can be convenient to check if the total number of indoor units which are installed match the total number of indoor units which are recognized by the system. In case there is a mismatch, It is advised to check the communication wiring path between outdoor and indoor units (F1/F2 communication line).

[1-13]= Shows the total number of connected outdoor units (in case of multiple outdoor system).  
It can be convenient to check if the total number of outdoor units which are installed matches the total number of outdoor units which are recognized by the system. In case there is a mismatch, It is advised to check the communication wiring path between outdoor and outdoor units (Q1/Q2 communication line).

[1-17]= Shows the latest malfunction code.

[1-18]= Shows the malfunction code which occurred 1 time before current malfunction code.

[1-19]= Shows the malfunction code which occurred 2 time before current malfunction code.  
  
When the latest malfunction codes were reset by accident on an indoor unit user interface, they can be checked again through this monitoring settings. For the content or reason behind the malfunction code see "16.2 Malfunction code list", where most relevant malfunction codes are explained. Detailed information about malfunction codes can be consulted in the service manual of this unit.

[1-38]= Shows the number of RA indoor units connected to the system.

[1-40]= Shows the current cooling comfort setting. See "15.3 Energy saving and optimum operation" for more details about this setting.

[1-41]= Shows the current heating comfort setting. See "15.3 Energy saving and optimum operation" for more details about this setting.

## 15.2 Mode 2

Mode 2 is used to change the field settings of the system. Consulting the current field setting value and changing the current field setting value is possible.

In general, normal operation can be resumed without special intervention after changing field settings.

Some field settings are used for special operation (e.g., 1 time operation, recovery/vacuuming setting, manual adding refrigerant setting, etc.). In such a case, it is required to abort the special operation before normal operation can restart. It will be indicated in below explanations.

[2-0]= Cool/Heat selection setting  
Default value=0.  

- 0=Each individual outdoor unit can select Cool/Heat operation
- 1=Master unit decides Cool/Heat operation when outdoor units are connected in multiple system combination
- 2=Slave unit for Cool/Heat operation when outdoor units are connected in multiple system combination

 Change [2-0]=0,1 or 2 in function of required functionality.

[2-8]=  $T_e$  target temperature  $T_e$  fix control  
Default value=2

Value [2-8]	$T_e$ target
2	6 (Default)
3	7
4	8
5	9
6	10
7	11

Change [2-8]=2~7 in function of required operation method during cooling.

This unit can operate with " $T_e$  fix control" and "Eco mode". Eco mode means "VRT" & "VRT smart" control.

[2-9]=  $T_c$  target temperature  $T_c$  fix control  
Default value=6

Value [2-9]	$T_c$ target
1	41
3	43
6	46 (Default)

Change [2-9]=1,3 or 6 in function of required operation method during heating.

This unit can operate with " $T_c$  fix control" and "Eco mode". Eco mode means "VRT" & "VRT smart" control.

[2-11]= Eco level setting for Eco mode via External control adaptor (Optional).

Value [2-11]	Meaning	Level
0	Inactive (Default)	—
1	Eco mode active by low noise terminal short-circuit	Standard
2	Eco mode active by demand terminal short-circuit	2-C short circuit = Low 3-C short circuit = Standard

Eco mode can be activated by short circuit the terminal on External control adaptor (Optional) according to [2-11] setting. ([2-23] should be "0")

This unit can operate with " $T_e$  or  $T_c$  fix control" and "Eco mode". Eco mode means "VRT" & "VRT smart" control.

If the terminal on external control adaptor is not connected by short circuit with [2-11]≠0, the system operates according to [2-8] or [2-9] setting.

[2-12]= Enable the low noise function and/or power consumption limitation via external control adaptor (DTA104A61/62)

If the system needs to be running under low noise operation or under power consumption limitation conditions when an external signal is sent to the unit, this setting should be changed. This setting will only be effective when the optional external control adaptor (DTA104A61/62) is installed.

Default value=0  
To activate this function change [2-12]=1.

[2-18]= Fan high static pressure setting  
In order to increase the static pressure the outdoor unit fan is delivering, this setting should be activated. For details about this setting, see technical specifications.  
Default value=0.  
To activate this function change [2-18]=1.

[2-20]= Manual additional refrigerant charge  
In order to add the additional refrigerant charge amount in a manual way (without automatic refrigerant charging functionality), following setting should be applied. Further instructions regarding the different ways to charge additional refrigerant into your system can be found in chapter "14.3 Method for adding refrigerant".  
Default value=0  
To activate this function change [2-20]=1

To stop the manual additional refrigerant charge operation (when the required additional refrigerant amount is charged), push BS3. If this function was not aborted by pushing BS3, the unit will stop its operation after 30 minutes. If 30 minutes was not sufficient to add the needed refrigerant amount, the function can be reactivated by changing the field setting again.

[2-21]= Refrigerant recovery/vacuuming mode  
In order to achieve a free pathway to reclaim refrigerant out of the system or to remove residual substances or to vacuum the system it is necessary to apply a setting which will open required valves in the refrigerant circuit so the reclaim of refrigerant or vacuuming process can be done properly.  
Default value=0  
To activate function change [2-21]=1

To stop the refrigerant recovery/vacuuming mode, push BS3. If BS3 is not pushed, the system will remain in refrigerant recovery/vacuuming mode.

[2-22]= Night time low noise setting and level  
By changing this setting, you activate the automatic low noise operation function of the unit and define the level of operation. Depending on the chosen level, the noise level will be lowered (4:Level4<3:Level3<2:Level2<1:Level1).  
The start and stop moments for this function are defined under setting [2-26] and [2-27].  
Default value=0.  
To activate function change [2-22]=1,2,3 or 4.

[2-23]= Eco mode invalid setting  
Eco mode becomes invalid by this setting  
When this configuration is set, it is not possible to turn Eco mode ON/OFF using external control adaptor or other setting.  
Default value=0, Eco mode is active.  
T<sub>e</sub> fix control [2-23]=1  
T<sub>c</sub> fix control [2-23]=2  
T<sub>e</sub> & T<sub>c</sub> fix control [2-23]=4

[2-25]= Low noise operation level via the external control adaptor  
If the system needs to be running under low noise operation conditions when an external signal is sent to the unit, this setting defines the level of low noise that will be applied (4:Level4<3:Level3<2:Level2<1:Level1).  
This setting will only be effective when the optional external control adaptor (DTA104A61/62) is installed and the setting [2-12] was activated.  
Default value=2.  
To activate function change [2-25]=1,2,3 or 4.

[2-26]= Low noise operation start time  
Change [2-26]=1,2 or 3 in function of required timing.  
Default value=2.

Value [2-26]	Start time Night time low noise operation (approximately)
1	22:00
2	22:00 (default)
3	24:00

This setting is used in conjunction with setting [2-22].

[2-27]= Low noise operation stop time  
Default value=3

Value [2-27]	Stop time Night time low noise operation (approximately)
1	6:00
2	7:00
3	8:00 (default)

This setting is used in conjunction with setting [2-22].

[2-30]= Power consumption limitation level (step 1) via the external control adaptor (DTA104A61/62).

If the system needs to be running under power consumption limitation conditions when an external signal is sent to the unit, this setting defines the level power consumption limitation that will be applied for step 1. The level is according to the table.

Default value=3

Change [2-30]=1,2,3,4,5,6,7 or 8 in function of required limitation.

Value [2-30]	Power consumption limitation (approximately)
1	60%
2	65%
3	70% (default)
4	75%
5	80%
6	85%
7	90%
8	95%

[2-31]= Power consumption limitation level (step 2) via the external control adaptor (DTA104A61/62).

If the system needs to be running under power consumption limitation conditions when an external signal is sent to the unit, this setting defines the level power consumption limitation that will be applied for step 2. The level is according to the table.

Default value=1.

Change [2-31]=1,2 or 3 in function of required limitation.

Value [2-31]	Power consumption limitation (approximately)
1	40% (default)
2	50%
3	55%

[2-32]= Forced, all time, power consumption limitation operation (no external control adaptor is required to perform power consumption limitation).

If the system always needs to be running under power consumption limitation conditions, this setting activates and defines the level power consumption limitation that will be applied continuously. The level is according to the table.

Default value=0 (OFF).

Value [2-32]	Restriction reference
0	Function not active (default)
1	Follows [2-30] setting
2	Follows [2-31] setting

Change [2-32]=0,1 or 2 in function of required limitation.

[2-49]= Max, level difference setting  
In case the outdoor location is higher than indoor, extension is possible up till 90 m, Refer to [2-49] for dedicated setting.

Value [2-49]	Max, level difference setting
0	OFF (default)
1	ON

[2-81]= Cooling comfort setting for VRT and VRT smart control  
Default value=1

Value [2-81]	Cooling comfort setting
0	Eco
1	Mild (default)
2	Quick
3	Powerful

Change [2-81]=0,1,2 or 3 in function of required limitation.

This setting is used in conjunction with setting [2-8]. For more information and advice about the impact of these settings, see "15.3 Energy saving and optimum operation".

[2-82]= Heating comfort setting for VRT and VRT smart control  
Default value=1

Value [2-82]	Heating comfort setting
0	Eco
1	Mild (default)
2	Quick
3	Powerful

Change [2-82]=0,1,2 or 3 in function of required limitation.

This setting is used in conjunction with setting [2-9]. For more information and advice about the impact of these settings, see "15.3 Energy saving and optimum operation".

[2-83]= Master user interface allocation in case VRV indoor units and RA indoor units are used at the same time. By changing setting [2-83], you can allow the VRV indoor unit to be the operation mode selector (system power OFF/ON is required after applying this setting).

- [2-83]=1 RA indoor unit has mode selection right (default setting).
- [2-83]=0 VRV indoor unit has mode selection right.

[2-90]= Indoor unit without power supply  
There are condition for this setting  
Ask Daikin sales company when this setting is necessary.

[2-96]= Eco level setting for Eco mode by main PCB  
Default value=0

Value [2-96]	Eco level setting
0	– (default)
1	Low
2	Standard

## 15.3 Energy saving and optimum operation

This VRV heat pump system is equipped with two kind of advanced energy saving functionality (VRT and VRT smart control). Detecting all connected indoor unit type, advanced energy saving functionality type is selected automatically. Depending on the priority, emphasises can be put on energy saving or comfort level. Several parameters can be selected, resulting in the optimal balance between energy consumption and comfort for the particular application.

Several patterns are available and explained below. Modify the parameters to the needs of your building and to realize the best balance between energy consumption and comfort.

### 15.3.1 Four main operation methods are available:

#### • Basic

The refrigerant temperature is fixed independent from the situation. It corresponds to the standard operation which is known and can be expected from/under previous VRV systems:

- To activate this operation method under cooling operation: Change field setting [2-23]=1 or disconnect the circuit between terminal on external control adapter with [2-11]≠0.
- To activate this operation method under heating operation: Change field setting [2-23]=2 or disconnect the circuit between terminal on external control adapter with [2-11]≠0.

#### • Automatic for VRT control

The refrigerant temperature is set depending on the outdoor ambient conditions. As such adjusting the refrigerant temperature to match the required load (which is also related to the outdoor ambient conditions).

E.g., when your system is operating in cooling, you do not need as much cooling under low outdoor ambient temperatures (e.g., 25°C) as under high outdoor ambient temperatures (e.g., 35°C). Using this idea, the system automatically starts increasing its refrigerant temperature, automatically reducing the delivered capacity and increasing the system's efficiency.

- This operation is selected automatically with checking connected indoor unit type.

E.g., when your system is operating in heating, you do not need as much heating under high outdoor ambient temperatures (e.g., 20°C) as under low outdoor ambient temperatures (e.g., -5°C). Using this idea, the system automatically starts decreasing its refrigerant temperature, automatically reducing the delivered capacity and increasing the system's efficiency.

- This operation is selected automatically with checking connected indoor unit type.

#### • Automatic for VRT smart control

The refrigerant temperature is set depending on the required capacity sent from every indoor unit.

- This operation is selected automatically with checking connected indoor unit type.

#### • Hi-sensible

The refrigerant temperature is set higher/lower (cooling/heating) compared to basic operation. The focus under high sensible mode is comfort feeling for the customer.

The selection method of indoor units is important and has to be considered as the available capacity is not the same as under basic operation. For details concerning to Hi-sensible applications, please contact your dealer.

- To activate this setting under cooling operation: change field setting [2-8] to the appropriate value, matching the requirements of the pre-designed system containing a high sensible solution.

Value [2-8]	T <sub>a</sub> target
3	7
4	8
5	9
6	10
7	11

- To activate this setting under heating operation: change field setting [2-9] to the appropriate value, matching the requirements of the pre-designed system containing a high sensible solution.

Value [2-9]	T <sub>c</sub> target
1	41
3	43

### 15.3.2 Several comfort settings are available in VRT control

For each of above modes automatic for VRT control and hi-sensible, a comfort level can be selected. The comfort level is related to the timing and the effort (energy consumption) which is put in achieving a certain room temperature by temporarily changing the refrigerant temperature to different values in order to achieve requested conditions more quickly.

#### • Powerful

Overshoot (during heating operation) or undershoot (during cooling operation) is allowed compare to the requested refrigerant temperature, in order to achieve the required room temperature very fast. The overshoot is allowed from the start up moment.

In case of cooling operation the evaporating temperature is allowed to go down to 3°C on temporary base depending on the situation.

In case of heating operation the condense temperature is allowed to go down to 49°C on temporary base depending on the situation.

When the request from the indoor units becomes more moderate, the system will eventually go to the steady state condition which is defined by the operation method above.

- To activate the powerful comfort setting under cooling operation, change field setting [2-81]=3.
- To activate the powerful comfort setting under heating operation, change field setting [2-82]=3.

#### • Quick

Overshoot (during heating operation) or undershoot (during cooling operation) is allowed compared to the requested refrigerant temperature, in order to achieve the required room temperature very fast. The overshoot is allowed from the start up moment.

In case of cooling operation the evaporating temperature is allowed to go down to 6°C on temporary base depending on the situation.

In case of heating operation the condense temperature is allowed to go up to 46°C on temporary base depending on the situation.

When the request from the indoor units becomes more moderate, the system will eventually go to the steady state condition which is defined by the operation method above.

- To achieve the quick comfort setting under cooling operation, change field setting [2-81]=2.
- To achieve the quick comfort setting under heating operation, change field setting [2-82]=2.

#### • Mild

Overshoot (during heating operation) or undershoot (during cooling operation) is allowed compared to the requested refrigerant temperature, in order to achieve the required room temperature very fast. The overshoot is not allowed from the start up moment. The start up occurs under the condition which is defined by the operation mode above.

In case of cooling operation the evaporating temperature is allowed to go down to 6°C on temporary base depending on the situation.

In case of heating operation the condense temperature is allowed to go up to 46°C on temporary base depending on the situation.

When the request from the indoor units becomes more moderate, the system will eventually go to the steady state condition which is defined by the operation method above.

The start up condition is different from the powerful and quick comfort setting.

- To activate the mild comfort setting under cooling operation, change field setting [2-81]=1.
- To activate the mild comfort setting under heating operation, change field setting [2-82]=1.

#### • Eco

The original refrigerant temperature target, which is defined by the operation method (see above) is kept without any correction, unless for protection control.

- To activate the eco comfort setting under cooling operation, change field setting [2-81]=0.
- To activate the eco comfort setting under heating operation, change field setting [2-82]=0.

No matter which control is selected, variations on the behaviour of the system are still possible due to protection controls to keep the unit operating under reliable conditions. The intentional target, however, is fixed and will be used to obtain the best balance between energy consumption and comfort, depending on the application type.

## 16. Test run

### 16.1 Test operation

After installation and once the field settings are defined, the installer is obliged to verify correct operation. Therefore a test run must be performed according to the procedures described below.

#### 16.1.1 Precautions before starting test operation

During test operation, the outdoor unit and the indoor units will start up:

- Make sure that the preparations of all indoor units are finished (field piping, electrical wiring, air purge, ...). See installation manual of the indoor units for details.



#### CAUTION

Do not insert fingers, rods or other objects into the air inlet or outlet. When the fan is rotating at high speed, it will cause injury.



#### CAUTION

**Do not perform the test operation while working on the indoor units.**

When performing the test operation, not only the outdoor unit, but the connected indoor unit will operate as well. Working on an indoor unit while performing a test operation is dangerous.



#### CAUTION

- During tests never pressurize the appliances with a pressure higher than the maximum allowable pressure (as indicated on the nameplate of the unit).
- If refrigerant gas leaks, ventilate the area immediately. Toxic gas may be produced if refrigerant gas comes into contact with fire.
- Never directly touch any accidental leaking refrigerant. This could result in severe wounds caused by frostbite.



#### DANGER: Do not touch piping and internal parts.

See "2. General safety precautions".



**DANGER: Electrical shock**

See "2. General safety precautions".

**INFORMATION**

Note that during the first running period of the unit, required power input may be higher. This phenomenon originates from the compressor that requires a 50 hour run elapse before reaching smooth operation and stable power consumption. Reason is that the scroll is made out of iron and that it takes some time to smooth the surfaces that make contact.

**16.1.2 Test operation**

The procedure below describes the test operation of the complete system. This operation checks and judges following items:

- Check of wrong wiring (communication check with indoor units).
- Check of the stop valves opening.
- Judgement of piping length.

On top of this system test operation, indoor units operation should also be checked separately.

- Make sure to carry out the system test operation after the first installation. Otherwise, the malfunction code U3 will be displayed on the user interface and normal operation or individual indoor unit test run cannot be carried out.
- Abnormalities on indoor units cannot be checked for each unit separately. After the test operation is finished, check the indoor units one by one by performing a normal operation using the user interface. Refer to the indoor unit installation manual for more details concerning the individual test run.

**INFORMATION**

- It may take 10 minutes to achieve a uniform refrigerant state before the compressor starts.
- During the test operation, the refrigerant running sound or the magnetic sound of a solenoid valve may become loud and the display indication may change. These are not malfunctions.

**Procedure**

- 1 Close all front panels in order to not let it be the cause of misjudgement (except the electrical component box inspection opening service cover).
- 2 Make sure all field settings you want are set.
- 3 Turn ON the power to the outdoor unit and the connected indoor units.

**NOTICE**

Be sure to turn on the power 6 hours before operation in order to have power running to the crankcase heater and to protect the compressor.

- 4 Make sure the default (idle) situation is existing; see "13.2 Operating the push buttons and DIP switches on the logic board". Push BS2 for 5 seconds or more. The unit will start test operation.

- The test operation is automatically carried out, the outdoor unit display will indicate "E01" and the indication "Test operation" and "Under centralized control" will display on the user interface of indoor units.

Steps during the automatic system test run procedure:

- "E01": control before start up (pressure equalization)
- "E02": cooling start up control
- "E03": cooling stable condition
- "E04": communication check
- "E05": stop valve check
- "E06": pipe length check
- "E07": refrigerant amount check
- "E08": in case [2-88]=0, detailed refrigerant situation check
- "E09": pump down operation
- "E10": unit stop

**INFORMATION**

If use Automatic refrigerant charge function "E07" and "E08" on test run will not show. It have been checked during the Automatic refrigerant charge operation.

- During the test operation, it is not possible to stop the unit operation from a user interface. To abort the operation, press BS3. The unit will stop after ±30 seconds.

- 5 Check the test operation results on the outdoor unit segment display.

- Normal completion: no indication on the segment display (idle)
- Abnormal completion: indication of malfunction code on the segment display  
Refer to "16.1.3 Correcting after abnormal completion of the test operation" to take action for correcting the abnormality. When the test operation is fully completed, normal operation will be possible after 5 minutes.

**16.1.3 Correcting after abnormal completion of the test operation**

The test operation is only completed if there is no malfunction code displayed on the user interface or outdoor unit segment display. In case of a displayed malfunction code, perform correcting actions as explained in the malfunction code table. Carry out the test operation again and confirm that the abnormality is properly corrected.

**INFORMATION**

Refer to the installation manual of the indoor unit for other detailed malfunction codes related to indoor units.

**16.2 Malfunction code list**

In case of a displayed malfunction code, perform correcting actions as explained in the malfunction code table.

After correcting the abnormality, press BS3 to reset the malfunction code and retry operation.

The malfunction code which is displayed on the outdoor unit will indicate a main malfunction code and a sub code. The sub code indicates more detailed information about the malfunction code. The malfunction code will be displayed intermittent.

Example:

Main code	Sub code
E3	- 01

With an interval of 1 second, the display will switch between main code and sub code.

Below table gives an overview of the malfunction codes which may appear.

Main code	Malfunction code			Contents	Solution
	Sub code				
	Master	Slave 1	Slave 2		
E3	01	03	05	High pressure switch was activated (S1PH) - A1P(X2A).	Check stop valve situation or abnormalities in (field) piping or airflow over air cooled coil.
	02	04	06	<ul style="list-style-type: none"> <li>Refrigerant overcharge.</li> <li>Stop valve closed.</li> </ul>	<ul style="list-style-type: none"> <li>Check refrigerant amount+recharge unit.</li> <li>Open stop valve.</li> </ul>
	13	14	15	Stop valve closed (liquid).	Open liquid stop valve.
	20	21	22	High pressure switch was activated (S2PH) - A1P(X3A).	Check stop valve situation or abnormalities in (field) piping or airflow over air cooled coil.
E4	01	02	03	Low pressure malfunction : <ul style="list-style-type: none"> <li>Stop valve closed.</li> <li>Refrigerant shortage.</li> <li>Indoor unit malfunction.</li> </ul>	<ul style="list-style-type: none"> <li>Open stop valve.</li> <li>Check refrigerant amount+recharge unit.</li> <li>Check the user interface's display or Transmission wiring between the outdoor unit and the indoor unit.</li> </ul>
E9	01	05	08	Electronic expansion valve malfunction (main) (Y1E) - A1P(X21A).	Check connection on PCB or actuator.
	03	06	09	Electronic expansion valve malfunction (subcool) (Y2E) - A1P(X22A).	Check connection on PCB or actuator.
	26	27	28	Electronic expansion valve malfunction (refrigerant auto charge) (Y4E) - A1P(X25A).	Check connection on PCB or actuator.
F3	01	03	05	Discharge temperature too high (R21T/R22T) : <ul style="list-style-type: none"> <li>Stop valve closed.</li> <li>Refrigerant shortage.</li> </ul>	<ul style="list-style-type: none"> <li>Open stop valve.</li> <li>Check refrigerant amount+recharge unit.</li> </ul>
	20	21	22	Compressor casing temperature too high (R8T/R9T) : <ul style="list-style-type: none"> <li>Stop valve closed.</li> <li>Refrigerant shortage.</li> </ul>	<ul style="list-style-type: none"> <li>Open stop valve.</li> <li>Check refrigerant amount+recharge unit.</li> </ul>
F6		02		<ul style="list-style-type: none"> <li>Refrigerant overcharge.</li> <li>Stop valve closed.</li> </ul>	<ul style="list-style-type: none"> <li>Check refrigerant amount+recharge unit.</li> <li>Open stop valve.</li> </ul>
H9	01	02	03	Ambient temperature sensor malfunction (R1T) - A1P(X18A).	Check connection on PCB or actuator.
J3	16	22	28	Discharge temperature sensor malfunction (R21T): open circuit - A1P (X19A).	Check connection on PCB or actuator.
	17	23	29	Discharge temperature sensor malfunction (R21T): short circuit - A1P (X19A).	Check connection on PCB or actuator.
	18	24	30	Discharge temperature sensor malfunction (R22T): open circuit - A1P (X19A).	Check connection on PCB or actuator.
	19	25	31	Discharge temperature sensor malfunction (R22T): short circuit - A1P (X19A).	Check connection on PCB or actuator.
	38	42	44	Compressor casing temperature sensor malfunction (R9T): open circuit - A1P (X19A).	Check connection on PCB or actuator.
	39	43	45	Compressor casing temperature sensor malfunction (R9T): short circuit - A1P (X19A).	Check connection on PCB or actuator.
	47	49	51	Compressor casing temperature sensor malfunction (R8T): open circuit - A1P (X19A).	Check connection on PCB or actuator.
	48	50	52	Compressor casing temperature sensor malfunction (R8T): short circuit - A1P (X19A).	Check connection on PCB or actuator.
J5	01	03	05	Suction temperature sensor malfunction (R3T) - A1P (X30A).	Check connection on PCB or actuator.
J6	01	02	03	De-icing temperature sensor malfunction (R7T) - A1P (X30A)	Check connection on PCB or actuator
J7	06	07	08	Liquid temperature sensor (after subcool HE) malfunction (R5T) - A1P (X30A).	Check connection on PCB or actuator.
J8	01	02	03	Liquid temperature sensor (coil) malfunction (R4T) - A1P (X30A).	Check connection on PCB or actuator.
J9	01	02	03	Gas temperature sensor (after subcool HE) malfunction (R6T) - A1P (X30A).	Check connection on PCB or actuator.
JR	06	08	10	High pressure sensor malfunction (S1NPH): open circuit - A1P (X32A).	Check connection on PCB or actuator.
	07	09	11	High pressure sensor malfunction (S1NPH): short circuit - A1P (X32A).	Check connection on PCB or actuator.
JC	06	08	10	Low pressure sensor malfunction (S1NPL): open circuit - A1P (X31A).	Check connection on PCB or actuator.
	07	09	11	Low pressure sensor malfunction (S1NPL): short circuit - A1P (X31A).	Check connection on PCB or actuator.
LE	14	15	16	Transmission outdoor unit - inverter: INV1 transmission trouble - A1P (X20A, X28A, X40A).	Check connection.
	19	20	21	Transmission outdoor unit - inverter: FAN1 transmission trouble - A1P (X20A, X28A, X40A).	Check connection.
	24	25	26	Transmission outdoor unit - inverter: FAN2 transmission trouble - A1P (X20A, X28A, X40A).	Check connection.
	30	31	32	Transmission outdoor unit - inverter: INV2 transmission trouble - A1P (X20A, X28A, X40A).	Check connection.

Malfunction code				Contents	Solution
Main code	Subcode				
	Master	Slave 1	Slave 2		
P1	01	02	03	INV1 unbalanced power supply voltage.	Check if power supply is within range.
	07	08	09	INV2 unbalanced power supply voltage.	Check if power supply is within range.
U1	16	17	18	Open phase for power supply.	Check if power supply is within range.
	19	20	21	Hz error for power supply.	Check if power supply is within range.
U2	01	08	11	INV1 voltage power shortage.	Check if power supply is within range.
	02	09	12	INV1 power phase loss.	Check if power supply is within range.
	22	25	28	INV2 voltage power shortage.	Check if power supply is within range.
	23	26	29	INV2 power phase loss.	Check if power supply is within range.
U3	03			Malfunction code: System test run not yet executed (system operation not possible).	Execute system test run.
	04			System test run abnormal ending.	Execute test run again.
U4	01			Faulty wiring to indoor - outdoor.	Check (F1/F2) wiring.
	03			Faulty indoor system.	Check indoor system transmissions wire.
U7	01			Warning: faulty wiring to Q1/Q2.	Check (Q1/Q2) wiring.
	02			Malfunction code: faulty wiring to Q1/Q2.	Check (Q1/Q2) wiring.
	11			<ul style="list-style-type: none"> <li>Too many indoor units are connected to F1/F2 line.</li> <li>Bad wiring between outdoor and indoor units.</li> </ul>	Check indoor unit amount and total capacity connected.
U9	01			<ul style="list-style-type: none"> <li>System mismatch. Wrong type of indoor units combined (R410A, R407C, RA).</li> <li>Indoor unit malfunction.</li> </ul>	Check if other indoor units have malfunction and confirm indoor unit mix is allowed.
UR	03			Connection malfunction over indoor units or type mismatch (R410A, R407C, RA).	Check if other indoor units have malfunction and confirm indoor unit mix is allowed.
	18			Connection malfunction over indoor units or type mismatch (R410A, R407C, RA).	Check if other indoor units have malfunction and confirm indoor unit mix is allowed.
	31			Wrong unit combination (multi system).	Check if unit types are compatible.
UF	01			Auto address malfunction (inconsistency).	Check if transmission wired unit amount matches with powered unit amount (by monitor mode) or wait till initialization is finished.
	05			Stop valve closed or wrong (during system test run).	Open stop valves.
UH	01			Auto address malfunction (inconsistency).	Check if transmission wired unit amount matches with powered unit amount (by monitor mode) or wait till initialization is finished.



## INFORMATION

References can be found on the wiring diagram.

Information code		Contents	Solution
Main code			
<i>Leak detection function related.</i>			
E-1		Unit is not prepared to execute leak detection operation.	Refer to requirements to be able to execute leak detection operation.
E-2		Indoor unit is out of temperature range for leak detection operation.	Retry when ambient conditions are satisfied.
E-3		Outdoor unit is out of temperature range for leak detection operation.	Retry when ambient conditions are satisfied.
E-4		Too low pressure was noticed during leak detection operation	Restart leak detection operation.
E-5		Indicates an indoor unit which is not compatible with leak detection functionality is installed.	Refer to requirements to be able to execute leak detection operation.
<i>Auto charging related.</i>			
P2		Unusual low pressure on suction line.	Close valve C immediately. Push BS3 to reset. Check following items before retrying auto charge procedure: <ul style="list-style-type: none"> <li>Check if the gas side stop valve is opened correctly.</li> <li>Check if the valve of the refrigerant cylinder is opened.</li> <li>Check if the air inlet and outlet of the indoor unit are not obstructed.</li> </ul>
P8		Freeze-up prevention indoor unit.	Close valve C immediately. Push BS3 to reset. Retry auto charge procedure.
PE		Automatic charging nearly finished.	Prepare for auto charge stopping.
P9		Automatic charging finished.	Finish auto charge mode.

## 17. Operation of the unit

Once the unit is installed and test operation of outdoor unit and indoor units is finished, the operation of the system can start.

For operating the indoor unit, the user interface of the indoor unit should be switched ON. Refer to the indoor unit operation manual for more details.

## 18. Caution for refrigerant leaks

### 18.1 Introduction

The installer and system specialist shall secure safety against leakage according to local regulations or standards. The following standards may be applicable if local regulations are not available.

This system uses R410A as refrigerant. R410A itself is an entirely safe non-toxic, non-combustible refrigerant. Nevertheless care must be taken to ensure that air conditioning facilities are installed in a room which is sufficiently large. This assures that the maximum concentration level of refrigerant gas is not exceeded, in the unlikely event of major leak in the system and this in accordance to the local applicable regulations and standards.

### 18.2 Maximum concentration level

The maximum charge of refrigerant and the calculation of the maximum concentration of refrigerant is directly related to the humanly occupied space in to which it could leak.

The unit of measurement of the concentration is  $\text{kg}/\text{m}^3$  (the weight in kg of the refrigerant gas in  $1\text{m}^3$  volume of the occupied space).

Compliance to the local applicable regulations and standards for the maximum allowable concentration level is required.

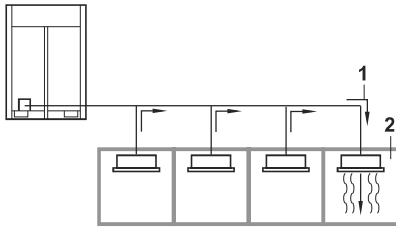

- 1 Direction of the refrigerant flow
- 2 Room where refrigerant leak has occurred (outflow of all the refrigerant from the system)

Pay special attention to places, such as basements etc., where refrigerant can stay, since refrigerant is heavier than air.

### 18.3 Procedure for checking maximum concentration

Check the maximum concentration level in accordance with steps 1 to 4 below and take whatever action is necessary to comply.

- 1 Calculate the amount of refrigerant (kg) charged to each system separately.

<p>Amount of refrigerant in a single unit system (amount of refrigerant with which the system is charged before leaving the factory)</p>	+	<p>Additional charging amount (amount of refrigerant added locally in accordance with the length or diameter of the refrigerant piping)</p>	=	<p>Total amount of refrigerant (kg) in the system</p>
--	---	---	---	---



#### NOTICE

Where a single refrigerant facility is divided into 2 entirely independent refrigerant systems, use the amount of refrigerant with which each separate system is charged.

- 2 Calculate the volume of the room ( $\text{m}^3$ ) where the indoor unit is installed.

In a case such as the following, calculate the volume of (A), (B) as a single room or as the smallest room.

- A Where there are no smaller room divisions:

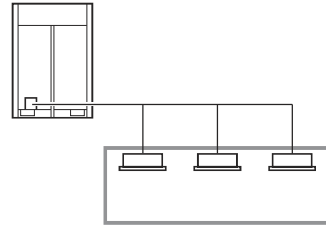

- B Where there is a room division, but there is an opening between the rooms sufficiently large to permit a free flow of air back and forth.

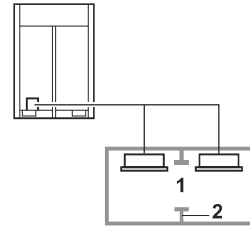

- 1 Opening between the rooms
  - 2 Partition
- (Where there is an opening without a door or where there are openings above and below the door which are each equivalent in size to 0.15% or more of the floor area.)

- 3 Calculating the refrigerant density using the results of the calculations in steps 1 and 2 above.

$$\frac{\text{Total volume of refrigerant in the refrigerant system}}{\text{Size (m}^3\text{) of smallest room in which there is an indoor unit installed}} \leq \text{Maximum concentration level (kg/m}^3\text{)}$$

If the result of the above calculation exceeds the maximum concentration level, a ventilation opening to the adjacent room shall be made.

- 4 After opening to the adjacent room are made, re-calculate. If result of calculation exceeds the maximum concentration level. Room re-modified are required, please contact your dealer.

**NOTE**

**NOTE**



# ***DAIKIN AIRCONDITIONING INDIA PVT. LTD.***

Head office:

12th Floor, Building No.9, Tower A,  
DLF Cyber City, DLF Phase-III,  
Gurgaon-122 002, Haryana, India  
[www.daikinindia.com](http://www.daikinindia.com)



**DAIKIN**



# OPERATION MANUAL

**VRV X** System Air Conditioner

RXYQ6ARY6  
RXYQ8ARY6  
RXYQ10ARY6  
RXYQ12ARY6  
RXYQ14ARY6  
RXYQ16ARY6  
RXYQ18ARY6  
RXYQ20ARY6

Thank you for purchasing this Daikin air conditioner. Carefully read this operation manual before using the air conditioner. It will tell you how to use the unit properly and help you if any trouble occurs. After reading the manual, keep it in your custody for future reference.

See also the operation manual included with the indoor unit for details on the indoor unit.

Store the operation manual included with the indoor unit together with this operation manual in a safe place.

After receiving the warranty card from the dealer, store it in a safe place.

# Operation manual

## Contents

	Page
1. Definitions.....	1
1.1. Meaning of warnings and symbols.....	1
1.2. Meaning of used terms.....	1
1.3. Safety precautions.....	2
2. Introduction.....	6
2.1. General information.....	6
2.2. System layout.....	6
3. Before operation.....	7
4. User interface.....	7
5. Operation range.....	7
6. Operation procedure.....	7
6.1. Cooling, heating, fan only, automatic operation and dry operation.....	7
6.2. Program dry operation.....	9
6.3. Adjusting the air flow direction.....	9
6.4. Setting the master user interface.....	10
6.5. Precautions for group control system or two user interface control system.....	11
7. Energy saving and optimum operation.....	11
8. Maintenance.....	12
8.1. Maintenance after a long stop period (e.g., at the beginning of the season).....	12
8.2. Maintenance before a long stop period (e.g., at the end of the season).....	12
9. Symptoms that are not air conditioner troubles.....	12
9.1. The system does not operate.....	12
9.2. Cool/Heat cannot be changed over.....	12
9.3. Fan operation is possible, but cooling/heating do not work.....	12
9.4. The fan strength does not correspond to the setting.....	12
9.5. The fan direction does not correspond to the setting.....	13
9.6. White mist comes out of a unit.....	13
9.7. The user interface display reads “U4” or “U5” and stops, but then restarts after a few minutes.....	13
9.8. Noise of air conditioners.....	13
9.9. Dust comes out of the unit.....	13
9.10. The units can give off odours.....	13
9.11. The outdoor unit fan does not spin.....	13
9.12. The display shows “  ”.....	13
9.13. The compressor in the outdoor unit does not stop after a short heating operation.....	13
9.14. The inside of an outdoor unit is warm even when the unit has stopped.....	13
9.15. Does not cool very well.....	13
9.16. Hot air can be felt when the indoor unit is stopped.....	13
10. Troubleshooting.....	14
11. After-sales service and warranty.....	14
11.1. Warranty period.....	14
11.2. After-sales service.....	14
11.3. Shortening of “maintenance cycle” and “replacement cycle” needs to be considered in following situations.....	15
11.4. Malfunction codes.....	16

## 1. Definitions

### 1.1. Meaning of warnings and symbols

Warnings in this manual are classified according to their severity and probability of occurrence.



#### **DANGER**

Indicates an imminently hazardous situation, which if not avoided, will result in death or serious injury.



#### **WARNING**

Indicates a potentially hazardous situation, which if not avoided, could result in death or serious injury.



#### **CAUTION**

Indicates a potentially hazardous situation, which if not avoided, may result in minor or moderate injury. It may also be used to alert against unsafe practices.



#### **NOTICE**

Indicates situations that may result in equipment or property-damage accidents only.



#### **INFORMATION**

This symbol identifies useful tips or additional information. Some types of danger are represented by special symbols:



Electric current.



Danger of burning and scalding.

### 1.2. Meaning of used terms

#### **Installation manual:**

Instruction manual specified for a certain product or application, explaining how to install, configure and maintain it.

#### **Operation manual:**

Instruction manual specified for a certain product or application, explaining how to operate it.

#### **Maintenance instructions:**

Instruction manual specified for a certain product or application, which explains (if relevant) how to install, configure, operate and/or maintain the product or application.

**Dealer:**

Sales distributor for products as per the subject of this manual.

**Installer:**

Technical skilled person who is qualified to install products as per the subject of this manual.

**User:**

Person who is owner of the product and/or operates the product.

**Service company:**

Qualified company which can perform or coordinate the required service to the unit.

**Applicable legislation:**

All international, European, national and local directives, laws, regulations and/or codes which are relevant and applicable for a certain product or domain.

**Accessories:**

Equipment which is delivered with the unit and which needs to be installed according to instructions in the documentation.

**Optional equipment:**

Equipment which can optionally be combined to the products as per the subject of this manual.

**Field supply:**

Equipment which needs to be installed according to instructions in this manual, but which are not supplied by Daikin.

**1.3. Safety precautions**

To gain full advantage of the air conditioner's functions and to avoid malfunction due to mishandling, we recommend that you read this instruction manual carefully before use.

Read the precautions thoroughly to avoid misuse of the equipment.

This air conditioner is classified under "appliances not accessible to the general public".

- The precautions described herein are classified as WARNING and CAUTION. They both contain important information regarding safety. Be sure to observe all precautions without fail.
- There are three kinds of safety precaution and tips listed in the following.



**WARNING.....** • Failure to follow these instructions properly may result in personal injury or loss of life.

- This unit contains electrical and hot parts.
- Before operating the unit, be sure the installation has been carried out correctly by an installer. If you feel unsure about operation, contact your installer for advice and information.



**CAUTION.....** • Failure to observe these instructions properly may result in property damage or personal injury, which may be serious depending on the circumstances.

- After reading, keep this manual in a convenient place so that you can refer to it whenever necessary. If the equipment is transferred to a new user, be sure also to hand over the manual.

**WARNING**

- **Do not place objects in direct proximity of the outdoor unit and do not let leaves and other debris accumulate around the unit.**

Leaves are a hotbed for small animals which can enter the unit.

Once in the unit, such animals can cause malfunctions, smoke or fire when making contact with electrical parts.

- **Consult your local dealer about installation work.** Doing the work yourself may result in water leakage, electric shocks or fire hazards.

- **Do not insert fingers, rods or other objects into the air inlet or outlet.**

When the fan is rotating at high speed, it will cause injury.

- **Never let the indoor unit or the user interface get wet.**

It may cause an electric shock or a fire.

- **Do not put user interface in risk to wet place.**

If water enter into controller, risk to electric leakage and cause to electronics parts damaged.

- **Be sure to use fuses with the correct ampere reading.**

Do not use improper fuses, copper or other wires as a substitute, as this may result in electric shock, fire, injury or damage to the unit.

- **Consult your local dealer regarding what to do in case of refrigerant leakage.**  
When the air conditioner is to be installed in a small room, it is necessary to take proper measures so that the amount of any leaked refrigerant does not exceed the concentration limit in the event of leakage. Otherwise, this may lead to an accident due to oxygen depletion.
- **Beware of fire in case of refrigerant leakage.**  
If the air conditioner is not operating correctly, i.e. not generating cool or warm air, refrigerant leakage could be the cause.  
Consult your dealer for assistance. The refrigerant within the air conditioner is safe and normally does not leak. However, in the event of a leakage, contact with a naked burner, heater or cooker may result in generation of noxious gas. Do not longer use air conditioner until a qualified service person confirms that the leakage has been repaired.
- **Do not use the air conditioner until a service person confirms that the portion where the refrigerant leaks happened is repaired.**
- **Turn off any combustible heating devices, ventilate the room and contact the dealer where you purchased the unit.**
- **Improper installation or attachment of equipment or accessories could result in electric shock, short circuit, leaks, fire or other damage to the equipment.**
- **Consult your local dealer regarding modification, repair and maintenance of the air conditioner.**  
Improper workmanship may result in water leakage, electric shocks or fire hazards.
- **Consult your local dealer regarding relocation and reinstallation of the air conditioner.**  
Improper installation work may result in leakage, electric shocks or fire hazards.
- **Before cleaning, be sure to stop the operation, turn the breaker off or pull out the supply cord.**  
Otherwise, an electric shock and injury may result.
- **Do not operate the air conditioner with wet hands.**  
An electric shock may result.
- **Do not wash the air conditioner with water, as this may result in electric shocks or fire.**
- **Be sure to install an earth leakage breaker.**  
Failure to install an earth leakage breaker may result in electric shocks or fire.  
In order to avoid electric shock or fire, make sure that an earth leak detector is installed.
- **Consult the dealer if the air conditioner submerges owing to a natural disaster, such as a flood or typhoon.**  
Do not operate the air conditioner in that case, or otherwise a malfunction, electric shock or fire may result.
- **Do not start or stop operating the air conditioner with the power supply breaker turned ON or OFF.**  
Otherwise, fire or water leakage may result. Furthermore, the fan will rotate abruptly if power failure compensation is enabled, which may result in injury.
- **Do not use the product in the atmosphere contaminated with oil vapor, such as cooking oil or machine oil vapor.**  
Oil vapor may cause crack damage, electric shocks or fire.
- **Do not install the air conditioner at any place where there is a danger of flammable gas leakage.**  
In case of a gas leakage, build-up of gas near the air conditioner may result in fire hazards.
- **Contact professional personnel about attachment of accessories and be sure to use only accessories specified by the manufacturer.**  
If a defect results from your own workmanship, it may result in water leaks, electric shock or fire.
- **Do not use the product in places with excessive oily smoke, such as cooking room, or in places with flammable gas, corrosive gas, or metal dust.**  
Using the product in such places may cause fire or product failures.
- **When the air conditioner is malfunctioning (giving off a burning odour, etc.) turn off power to the unit and contact your local dealer.**  
Continued operation under such circumstances may result in a failure, electric shocks or fire hazards.
- **Do not place flammable sprays or operate spray containers near the unit as this may result in fire.**
- **Do not clean the product with organic solvents such as paint thinner.**  
The use of organic solvents may cause crack damage to the product, electric shocks or fire.

- **Be sure to use a dedicated power supply for the air conditioner.**

The use of any other power supply may cause heat generation, fire or product failures.

- **Consult your dealer regarding cleaning the inside of the air conditioner.**

Improper cleaning may cause breakage of plastic parts, water leakage and other damage as well as electric shocks.

- **Be sure the air conditioner is electrically earthed.**

In order to avoid electric shock, make sure that the unit is grounded and that the earth wire is not connected to gas or water pipe, lightning conductor or telephone earth wire.

- **Do not place a flower vase or anything containing water on the unit. Water may enter the unit, causing an electric shock or fire.**

- **Avoid placing the controller in a spot which can be splashed with water. Water entering the machine may cause an electric leak or may damage the internal electronic parts.**

- **Be aware that prolonged, direct exposure to cool or warm air from the air conditioner or to air that is too cool or too warm can be harmful to your physical condition and health.**

### CAUTION

- **Do not remove the outdoor unit's fan guard.**

The guard protects against the unit's high speed fan, which may cause injury.

- **Do not place objects that are susceptible to moisture directly beneath the indoor or outdoor units.**

Under certain conditions, condensation on the main unit or refrigerant pipes, air filter dirt or drain blockage may cause dripping, resulting in fouling or failure of the object concerned.

- **To avoid oxygen depletion, ensure that the room is adequately ventilated if equipment such as a burner is used together with the air conditioner.**

- **Do not place flammable sprays near the unit as this can cause explosions.**

- **Do not place appliances that produce naked flames in places exposed to the air flow from the unit as this may impair combustion of the burner.**

- **Do not place burners or heaters in places exposed to the air flow from the unit as this may impair combustion of the burner or heater.**

- **Do not place heaters directly below the unit, as resulting heat can cause deformation.**

- **Do not allow a child to mount on the outdoor unit or avoid placing any object on it.**

Falling or tumbling may result in injury.

- **Do not block air inlets or outlets.**

Impaired air flow may result in insufficient performance or trouble.

- **Arrange the drain hose to ensure smooth drainage.**

Imperfect drainage may cause wetting of the building, furniture etc.

- **Arrange the drain hose to ensure smooth drainage.**

Imperfect drainage may cause wetting.

- **Be sure that children, plants or animals are not exposed directly to air flow from the unit, as adverse effects may ensue.**

- **Do not wash air conditioner or user interface, causing an electric shock or fire.**

- **Do not put flammable containers, such as spray cans, within 1 m from the blow-off mouth.**

The containers may explode because the warm air output of the outdoor unit will affect them.

- **Arrange the drain to ensure complete drainage.**

If proper drainage from the outdoor drain pipe does not occur during air conditioner operation, there could be a blockage due to dirt and debris build-up in the pipe.

This may result in a water leakage from the indoor unit. Under these circumstances, stop air conditioner operation and consult your dealer for assistance.

- **The appliance is not intended for use by unattended young children or infirm persons.** Impairment of bodily functions and harm to health may result.

- **Children should be supervised to ensure that they do not play with the unit or its user interface.**

Accidental operation by a child may result in impairment of bodily functions and harm health.

- **To avoid injury, do not touch the air inlet or aluminium fins of the unit.**  
These fins are sharp and could result in cutting injuries.
  - **Never touch the internal parts of the controller.**  
Do not remove the front panel. Touching certain internal parts will cause electric shocks and damage to the unit. Please consult your dealer about checking and adjustment of internal parts.
  - **Do not leave user interface wherever there is a risk of wetting.**  
If water gets into the remote controller there is a risk of electrical leakage and damage to electronic components.
  - **Turn off the main power switch when the air conditioner is not to be used for prolonged periods.**  
When the main power switch is left on, some electric power (watts) is still consumed even if the air conditioner is not operating. Therefore, switch off the main power switch to save energy. When resuming operation, to ensure smooth running, turn on the main power switch 6 hours before operating the air conditioner again.
  - **Watch your steps at the time of air filter cleaning or inspection.**  
High-place work is required, to which utmost attention must be paid.  
If the scaffold is unstable, you may fall or topple down, thus causing injury.
  - **Take care of scaffolding and exercise caution when working high above ground level.**
  - **Do not operate with the control panel lid open.**  
If water gets inside the panel, it may result in equipment failure or electric shock.
  - **Do not sit or place objects on the outdoor unit**  
Falling yourself or objects could cause injury.
  - **Do not let children play on or around the outdoor unit.**  
If they touch the unit carelessly, injury may be caused.
  - **Never operate user interface buttons with hard, pointed objects.**  
This may result in remote controller damage.
  - **Do not pull or twist user interface cord.**  
This may cause malfunctioning.
  - **Do not use the air conditioner for purposes other than those for which it is intended.**  
Do not use the air conditioner for cooling precision instruments, food, plants, animals or works of art as this may adversely affect the performance, quality and/or longevity of the object concerned
  - **After prolonged use, check the unit stand and its mounts for damage.**  
If left in a damaged condition, the unit may fall and cause injury.
  - **Do not place items which might be damaged by moisture under the indoor unit.**  
Condensation may form if the humidity is above 80%, if the drain outlet is blocked or the filter is polluted.
  - **Ensure that user interface is not exposed to direct sunlight.**  
This will cause discoloration of the LCD display with resulting loss of readability.
  - **Do not wipe the controller panel with benzene or other organic solvent.**  
This will cause discoloration and/or peeling. If the panel needs cleaning, use a damp cloth with some water-diluted neutral detergent. Wipe with a dry cloth afterwards.
  - **Do not operate the air conditioner when using a room fumigation type insecticide.**  
Fumigation chemicals deposited in the unit could endanger the health of those who are hyper-sensitive to touch chemicals.
-

## Installation Site

### Regarding places for installation

- **Install the air conditioner in a well-ventilated place that is free of obstructions**
- **Do not use the air conditioner in the following kinds of places:**
  - a. Where there is considerable use of mineral oil such as cutting oil.
  - b. Where there is much salt such as a beach area.
  - c. Where there is sulphur gas such as in a hot-spring resort.
  - d. Where there are considerable voltage fluctuations such as a factory.
  - e. Where there are motor vehicles or marine vessels.
  - f. Where there is considerable atmospheric oil such as in cooking areas.
  - g. Where there are machines generating electromagnetic radiation.
  - h. Where the air contains acidic or alkaline steam or a vapour.

### Wiring

- **All wiring must be performed by an authorized electrician.**

Always consult your dealer about wiring.  
Never do it by yourself.
- **Only use the dedicated power supply circuit provided for this air conditioner.**

### Also pay attention to operating noise.

- **Select the following kinds of location:**
  - a. A place that can sufficiently withstand the weight of the air conditioner with less running noises and vibrations.
  - b. A place where warm airflow from the air outlet of the outdoor unit and operating noise do not cause a nuisance to neighbours.
- **Be sure there are no obstructions near the air outlet of the outdoor unit.**
- **Obstructions may result in poor performance and increased operating noise.**

If abnormal noise occur, ask your dealer for advise.
- **Make sure that the piping is heat insulated.**

If the piping is frozen and broken, scalding or water leakage may result.  
Consult your installer.

### System relocation

- **Consult your Daikin about remodelling and relocation.**

## 2. Introduction

### 2.1. General information

The indoor unit part of VRV heat pump system can be used for heating/cooling applications. The type of indoor unit which can be used depends on the outdoor units series.

#### NOTICE

For future modifications or expansions of your system:

A full overview of allowable combinations (for future system extensions) is available in technical engineering data and should be consulted. Contact your installer to receive more information and professional advice.

In general following type of indoor units can be connected to a VRV heat pump system (not exhaustive list, depending on outdoor unit model and indoor unit model combinations):

- VRV direct expansion indoor units (air to air applications).
- RA direct expansion indoor units (air to air applications).

Combination of VRV direct expansion indoor units with RA direct expansion units is allowed.

For more specifications, see technical engineering data.

### 2.2. System layout

Your VRV heat pump series outdoor unit can be one of following models: RXYQ: Single and multi non-continuous heating model.

Depending on the type of outdoor unit which is chosen, some functionality will or will not exist. It will be indicated throughout this operation manual when certain features have exclusive model rights or not.

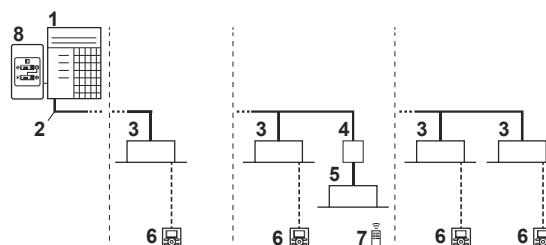

1. VRV outdoor unit
2. Refrigerant piping
3. VRV direct expansion indoor unit
4. BP unit (required to connect Residential Air or Sky Air indoor units)
5. Residential Air Direct Expansion indoor units
6. User interface (dedicated depending on indoor unit type)
7. User interface (wireless, dedicated depending on indoor unit type)
8. Cool/Heat changeover remote control switch.



### 3. Before operation

This operation manual is for the following systems with standard control. Before initiating operation, contact your dealer for the operation that corresponds to your system type and mark. If your installation has a customized control system, ask your dealer for the operation that corresponds to your system.

Operation modes (depending on indoor unit type):

- Heating and Cooling (air to air). ☀️ ❄️
- Fan only operation (air to air). 🌀
- Dry operation. 💧
- Automatic operation. ⏸️

Dedicated functions exist depending on the type of indoor unit, refer to dedicated installation/operation manual for more information.

### 4. User interface

This operation manual will give a non-exhaustive overview of the main functions of the system.

Detailed information on required actions to achieve certain functions can be found in the dedicated installation and operation manual of the indoor unit.

Refer to the operation manual of the installed user interface.

### 5. Operation range

Use the system in the following temperature and humidity ranges for safe and effective operation.

	❄️	☀️
Outdoor temperature	-5~49°C DB	-20~21°C DB -20~15.5°C WB
Indoor temperature	21~32°C DB 14~25°C WB	15~27°C DB
Indoor humidity	≤80%(a)	



(a) To avoid condensation and water dripping out of the unit. If the temperature or the humidity is beyond these conditions, safety devices may be put in action and the air conditioner may not operate.

Above operation range is only valid in case direct expansion indoor units are connected to the VRV system.

### 6. Operation procedure

- Operation procedure varies according to the combination of outdoor unit and user interface. Read the chapter 3 “Before operation”
- To protect the unit, turn on the main power switch 6 hours before operation. And do not turn off the power supply during the air conditioning season because of smoothly start up.
- If the main power supply is turned off during operation, operation will restart automatically after the power turns back on again.

#### 6.1 Cooling, heating, fan only, automatic operation and dry operation

- The operation mode cannot be changed with the remote controller whose display shows “” (change over under centralized control). Change the operation mode with user interface whose display dose not show “”.
- When the display  “change over under centralized control” flashes, refer to “6.4. Setting the master user interface”
- The fan may keep on running for about 1 minute after the heating operation stops for removing the heat in the indoor unit.
- The air flow rate may adjust itself depending on the room temperature or the fan may stop immediately. This is not a malfunction.

#### FOR SYSTEM WITHOUT COOL / HEAT SELECTOR

#### STARTING THE SYSTEM

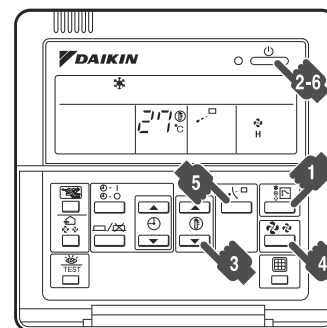

- 1 Press the operation mode selector button several times and select the operation mode of your choice
  - “ ❄️ ” Cooling operation
  - “ ☀️ ” Heating operation
  - “ 🌀 ” Fan only operation
  - “ 💧 ” Dry operation
  - “ ⏸️ ” Automatic operation.
- 2 Press the ON/OFF button. The operation lamp lights up and the system starts operation.

## Overview of the changeover remote control switch

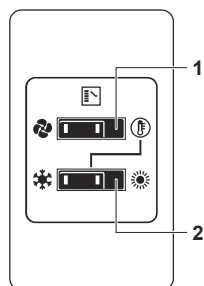

- 1. FAN ONLY/AIR CONDITIONING SELECTOR SWITCH**  
Set the switch to for fan only operation or to for heating or cooling operation.
- 2. COOL/HEAT CHANGEOVER SWITCH**  
Set the switch to for cooling or to for heating.

## Operating the changeover remote control switch

- Select operation mode with the cool/heat changeover switch as follows:

Cooling operation Heating operation Fan only operation

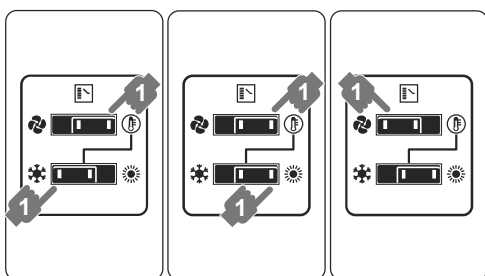

- Press the ON/OFF button on the user interface.  
The operation lamp lights up and the system starts operating.

### ADJUSTMENT

For adjustment the desired temperature, fan speed and air flow direction (only for the remote controller, follow the procedure shown below.)

- Press the temperature setting button

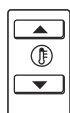

Each time this button is pressed, the temperature setting rises or lowers 1°C.

### NOTE

- Set the temperature within the operation range.
  - The temperature setting is impossible for fan only operation.
- Press the fan speed control button and select the fan speed of your preference.
  - Press air flow direction adjust button.  
Refer to the chapter “6.3 Adjusting the air flow direction” for details.

### STOPPING THE SYSTEM

- Press the ON/OFF button once again.  
The operation lamp goes off and the system stops operation.

## NOTICE

- Do not turn off the power immediately after the unit stops, but wait for at least 5 minutes.
- The system need at least 5 minutes for residual operation of drain pump device.  
Turning off the power immediately will cause water leak or trouble.

## Explanation of heating operation

It may take longer to reach the set temperature for general heating operation than for cooling operation.

The following operation is performed in order to prevent the heating capacity from dropping or cold air from blowing.

## Defrost operation

- In heating operation, freezing of the outdoor unit's air cooled coil increases over time, restricting the energy transfer to the outdoor unit's coil. Heating capability decreases and the system needs to go into defrost operation to be able to deliver enough heat to the indoor units:
- When a RXYQ outdoor unit is installed, the indoor unit will stop fan operation, the refrigerant cycle will reverse and energy from inside the building will be used to defrost the outdoor unit coil.
- The indoor unit will indicate defrost operation on the displays .

## Hot start

- In order to prevent cold air from blowing out of an indoor unit at the start of heating operation, the indoor fan is automatically stopped. The display of the user interface shows . It may take some time before the fan starts. This is not a malfunction.

## INFORMATION

- The heating capacity drops when the outside temperature falls. If this happens, use another heating device together with the unit. (When using together with appliances that produce open fire, ventilate the room constantly).  
Do not place appliances that produce open fire in places exposed to the air flow from the unit or under the unit.
- It takes some time to heat up the room from the time the unit is started since the unit uses a hot-air circulating system to heat the entire room.
- If the hot air rises to the ceiling, leaving the area above the floor cold, we recommend that you use the circulator (the indoor fan for circulating air). Contact your dealer for details.

## 6.2 Program dry operation

- The function of this program is to decrease the humidity in your room with minimal temperature decrease (minimal room cooling).
- The microcomputer automatically determines temperature and fan speed (cannot be set by the user interface).
- The system does not go into operation if the room temperature is low (<20°C).

### FOR SYSTEM WITHOUT COOL / HEAT SELECTOR

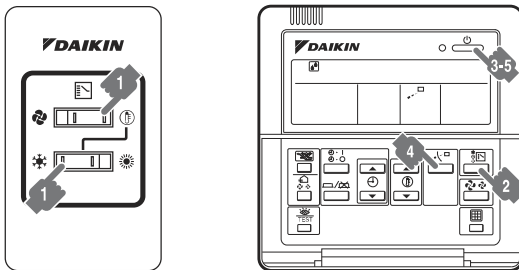

### Starting the system

1. Select cooling operation mode with the cool/heat changeover remote control switch.
2. Press the operation mode selector button several times and select  (program dry operation).
3. Press the ON/OFF button of the user interface. The operation lamp lights up and the system starts operating.
4. Press the air flow direction adjust button (only for Double-flow, Multi-flow, Corner, Ceiling-suspended and Wall-mounted). Refer to "6.3 Adjusting the air flow direction".

### Stopping the system

5. Press the ON/OFF button of the user interface once again. The operation lamp goes off and the system stops operating.



### NOTICE

Do not turn off power immediately after the unit stops, but wait for at least 5 minutes.

## 6.3 Adjusting the air flow direction

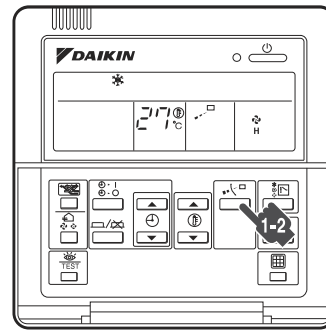

1. Press the air flow direction button to select the air direction.

The air flow flap display swings as shown right and the air flow direction continuously varies. (Automatic swing setting)



2. Press the air flow direction adjust button to select the air direction of your choice.



The air flow flap display stops swinging and the air flow direction is fixed. (Fixed air flow direction setting)



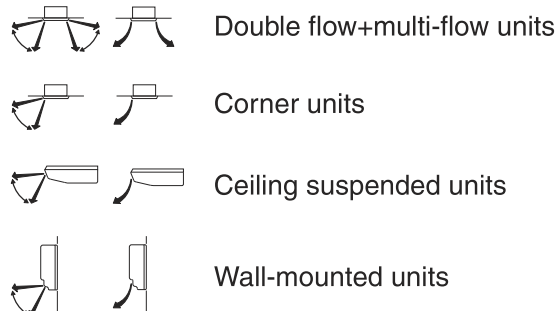

### Movement of the air flow flap



For the following conditions, a microcomputer controls the air flow direction which may be different from the display.

COOLING	HEATING
<ul style="list-style-type: none"> <li>• When the room temperature is lower than the set temperature.</li> </ul>	<ul style="list-style-type: none"> <li>• When starting operation.</li> <li>• When the room temperature is higher than the set temperature.</li> <li>• At defrost operation.</li> </ul>
<ul style="list-style-type: none"> <li>• When operating continuously at horizontal air flow direction.</li> <li>• When continuous operation with downward air flow is performed at the time of cooling with a ceiling-suspended or a wall-mounted unit, the microcomputer may control the flow direction, and then the user interface indication will also change.</li> </ul>	

The air flow direction can be adjusted in one of the following ways:

- The air flow flap itself adjusts its position.
- The air flow direction can be fixed by the user.  
Automatic  or desired position 

**NOTICE**

- The movable limit of the flap is changeable. Contact your dealer for details. (only for double-flow, multiflow, corner, ceiling-suspended and wall-mounted).
- Avoid operating in the horizontal direction . It may cause dew or dust to settle on the ceiling or flap.

**6.4 Setting the master user interface**

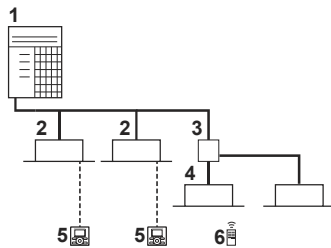

1. VRV heat pump outdoor unit
2. VRV direct expansion indoor unit
3. BP unit (required to connect Residential Air or Sky Air Direct Expansion indoor units)
4. Residential Air Direct Expansion indoor units
5. User interface (dedicated depending on indoor unit type)
6. User interface (wireless, dedicated depending on indoor unit type)

When the system is installed as shown in the figure above, it is necessary to designate one of the user interfaces as the master user interface. The displays of slave user interfaces show  (change over under centralized control) and slave user interfaces automatically follow the operation mode directed by the master user interface.

Only the master user interface can select heating or cooling or fan only mode.

Indoor unit master allocation is determined as follows in special cases:

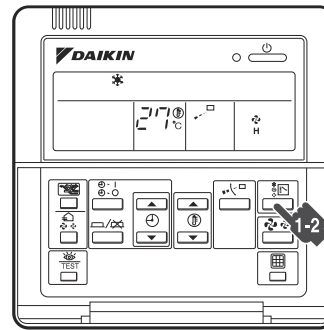

- In case of VRV indoor units combined with RA indoor units, the operation mode is by default selected by the master user interface of the RA indoor unit. Contact your installer if you wish to know which indoor unit type received the master allocation.

**How to designate the master user interface**



**In case only VRV indoor units are connected to the VRV system:**

**1** Press the operation mode selector button of the current master user interface for 4 seconds. In case this procedure was not yet performed, the procedure can be executed on the first user interface operated. The display showing  (change over under centralized control) of all slave user interfaces connected to the same outdoor unit flashes.

**2** Press the operation mode selector button of the controller that you wish to designate as the master user interface. Then designation is completed. This user interface is designated as the master user interface and the display showing  (change over under centralized control) vanishes. The displays of other user interfaces show  (change over under centralized control).

**In case VRV indoor units and RA indoor units are connected (or only RA indoor units):**

Depending on field setting which was executed on the outdoor unit, the right for master selection lies with the VRV indoor unit or the RA indoor unit (see below).

1. In case the VRV indoor unit is assigned as master selector, the same procedure as above can be followed.
2. In case the RA indoor unit is assigned as master selector, following procedure can be followed.

Procedure: stop all indoor units (VRV indoor+RA indoor units).

When the system is not operating (all indoor units thermo OFF), you can define the master RA indoor unit by addressing that unit with infrared user interface (instruct thermo ON in desired mode).

The only way to change the master unit is by repeating the previous procedure.

A cool/heat switchover (or opposite) is only possible by changing the operation mode of the defined master indoor unit.

In case you want to keep the VRV indoor unit user interface as master, contact your installer.

### 6.5 Precautions for group control system or two user interface control system

This system provides two other control systems beside individual control system (one user interface controls one indoor unit). Confirm the following if your unit is of the following control system type:

#### • **Group control system**

One user interface controls up to 16 indoor units. All indoor units are equally set.

#### • **Two user interface control system**

Two user interfaces control one indoor unit (in case of group control system, one group of indoor units). The unit is individually operated.

---

#### **NOTICE**

Contact your dealer in case of changing the combination or setting of group control and two user interface control systems.

---

#### **INFORMATION**

For another user interfaces refer to the operation manual of the operation procedure user interface.

---

## 7. Energy saving and optimum operation

Observe the following precautions to ensure the system operates properly.

- Adjust the air outlet properly and avoid direct air flow to room inhabitants.
- Adjust the room temperature properly for a comfortable environment. Avoid excessive heating or cooling.
- Prevent direct sunlight from entering a room during cooling operation by using curtains or blinds.
- Ventilate often.  
Extended use requires special attention to ventilation.

- Keep doors and windows closed. If the doors and windows remain open, air will flow out of your room causing a decrease in the cooling or heating effect.
- Be careful not to cool or heat too much. To save energy, keep the temperature setting at a moderate level.
- Never place objects near the air inlet or the air outlet of the unit.  
It may cause deterioration in the effect or stop the operation.
- Turn off the main power supply switch to the unit when the unit is not used for longer periods of time. If the switch is on, it consumes electricity. Before restarting the unit, turn on the main power supply switch 6 hours before operation to ensure smooth running. (Refer to "Maintenance" in the indoor unit manual.)
- When the display shows  (time to clean the air filter), ask a qualified service person to clean the filters. (Refer to "Maintenance" in the indoor unit manual.)
- Keep the indoor unit and user interface at least 1 m away from televisions, radios, stereos, and other similar equipment. Failing to do so may cause static or distorted pictures.
- Do not place items under the indoor unit, they may be damaged by water.
- Condensation may form if the humidity is above 80% or if the drain outlet gets blocked.

Your system is equipped with advanced energy saving functionality. Depending on the priority emphasises can be put on energy saving or comfort level. Several parameters can be selected, resulting in the optimal balance between energy consumption and comfort for your particular application.

Several patterns are available and roughly explained below. Contact your installer or dealer for advice or to modify the parameters to the needs of your building.

Detailed information is given for the installer in the installation manual. He can help you to realize the best balance between energy consumption and comfort.

## 8. Maintenance

### CAUTION

Pay attention to the fan.  
It is dangerous to inspect the unit while the fan is running.

Be sure to turn off the main switch and to remove the fuses from the control circuit located in the outdoor unit.

#### 8.1 Maintenance after a long stop period (e.g., at the beginning of the season)

- Check and remove everything that might be blocking inlet and outlet vents of indoor units and outdoor units.
- Clean air filters and casings of indoor units.<sup>(b)</sup> Refer to the operation manual supplied with the indoor units for details on how to proceed and make sure to install for details on how to proceed and make sure to install cleaned air filters back in the same position.
- Turn on the power at least 6 hours before operating the unit in order to ensure smoother operation. As soon as the power is turned on, the user interface display appears.

<sup>(b)</sup> Contact your installation or maintenance person to clean air filters and casings of the indoor unit. Maintenance tips and procedures for cleaning are provided in the installation/operation manuals of dedicated indoor units.

#### 8.2 Maintenance before a long stop period (e.g., at the end of the season)

- Let the indoor units run in fan only operation for about half a day in order to dry the interior of the units.  
Refer to “6.1. Cooling, heating, fan only, automatic operation and dry operation”.
- Turn off the power. The user interface display disappears.
- Clean air filters and casings of indoor units. Refer to the operation manual supplied with the indoor units for details on how to proceed and make sure to install cleaned air filters back in the same position.



## 9. Symptoms that are not air conditioner troubles

Following symptoms are not air conditioner troubles:

### 9.1 The system does not operate

- The air conditioner does not start immediately after the ON/OFF button on the user interface is pressed. If the operation lamp lights, the system is in normal condition. To prevent overloading of the compressor motor, the air conditioner starts 5 minutes after it is turned ON again in case it was turned OFF just before.  
The same starting delay occurs after the operation mode selector button was used.
- If "Under Centralized Control" is displayed on the user interface and pressing the operation button causes the display to blink for a few seconds indicating that the central device is controlling the unit. The blinking display indicates that the user interface cannot be used.
- The system does not start immediately after the power supply is turned on. Wait one minute until the microcomputer is prepared for operation.

### 9.2 Cool/Heat cannot be changed over

- When the display shows  (change-over under centralized control), it shows that this is a slave user interface.
- When the cool/heat changeover remote control switch is installed and the display shows  (change-over under centralized control). This is because cool/heat changeover is controlled by the cool/heat changeover remote control switch. Ask your dealer where the remote control switch is installed.

### 9.3 Fan operation is possible, but cooling/heating do not work

- Immediately after the power is turned on. The microcomputer is getting ready to operate and is performing a communication check with all indoor units. Please wait 12 minutes (max.) till this process is finished.

### 9.4 The fan strength does not correspond to the setting

- The fan speed does not change even if the fan speed adjustment button is pressed. During heating operation, when the room temperature reaches the set temperature, the outdoor unit goes off and the indoor unit changes to whisper fan speed. This is to prevent cold air blowing directly on occupants of the room. The fan speed will not change even if the button is pressed, when another indoor unit is in heating operation.

### **9.5 The fan direction does not correspond to the setting**

- The fan direction does not correspond with the user interface display. The fan direction does not swing. This is because the unit is being controlled by the microcomputer.

### **9.6 White mist comes out of a unit**

- 1.) Indoor unit
  - When humidity is high during cooling operation. If the interior of an indoor unit is extremely contaminated, the temperature distribution inside a room becomes uneven. It is necessary to clean the interior of the indoor unit. Ask your dealer for details on cleaning the unit. This operation requires a qualified service person.
  - Immediately after the cooling operation stops and if the room temperature and humidity are low. This is because warm refrigerant gas flows back into the indoor unit and generates steam.
- 2.) Indoor unit, outdoor unit
  - When the system is changed over to heating operation after defrost operation. Moisture generated by defrost becomes steam and is exhausted.

### **9.7 The user interface display reads “U4” or “U5” and stops, but then restarts after a few minutes**

- This is because the user interface is intercepting noise from electric appliances other than the air conditioner. The noise prevents communication between the units, causing them to stop. Operation automatically restarts when the noise ceases.

### **9.8 Noise of air conditioners**

- 1.) Indoor unit
  - A “zeen” sound is heard immediately after the power supply is turned on. The electronic expansion valve inside an indoor unit starts working and makes the noise. Its volume will reduce in about one minute.
  - A continuous low “shah” sound is heard when the system is in cooling operation or at a stop. When the drain pump (optional accessories) is in operation, this noise is heard.
  - A low “sah”, “choro-choro” sound is heard while the indoor unit is stopped. When the other indoor unit is in operation, this noise is heard. In order to prevent oil and refrigerant from remaining in the system, a small amount of refrigerant is kept flowing.
  - A “pishi-pishi” squeaking sound is heard when the system stops after heating operation. Expansion and contraction of plastic parts caused by temperature change make this noise.

- 2.) Indoor unit, outdoor unit

- A continuous low hissing sound is heard when the system is in cooling or defrost operation. This is the sound of refrigerant gas flowing through both indoor and outdoor units.
- A hissing sound which is heard at the start or immediately after stopping operation or defrost operation. This is the noise of refrigerant caused by flow stop or flow change.

- 3.) Outdoor unit

- When the tone of operating noise changes. This noise is caused by the change of frequency.

### **9.9 Dust comes out of the unit**

- When the unit is used for the first time in a long time. This is because dust has gotten into the unit.

### **9.10 The units can give off odours**

- The unit can absorb the smell of rooms, furniture, cigarettes, etc., and then emit it again.

### **9.11 The outdoor unit fan does not spin**

- The speed of the fan is controlled in order to optimise product operation.

### **9.12 The display shows “88”**

- This is the case immediately after the main power supply switch is turned on and means that the user interface is in normal condition. This continues for one minute.

### **9.13 The compressor in the outdoor unit does not stop after a short heating operation.**

- This is to prevent oil and refrigerant from remaining in the compressor. The unit will stop after 5 to 10 minutes.

### **9.14 The inside of an outdoor unit is warm even when the unit has stopped**

- This is because the crankcase heater is warming the compressor so that the compressor can start smoothly.

### **9.15 Does not cool very well**

- Program dry operation. Program dry operation is designed to lower the room temperature as little as possible refer to “6.2 Program dry operation”

### **9.16 Hot air can be felt when the indoor unit is stopped**

- Several different indoor units are being run on the same system. When another unit is running, some refrigerant will still flow through the unit.

## 10. Troubleshooting

If one of the following malfunctions occur, take the measures shown below and contact your dealer.

### WARNING

Stop operation and shut off the power if anything unusual occurs (burning smells etc.)

Leaving the unit running under such circumstances may cause breakage, electric shock or fire. Contact your dealer.

The system must be repaired by a qualified service person :

- If a safety device such as a fuse, a breaker or an earth leakage breaker frequently actuates or the ON/OFF switch does not properly work.  
Measure: Turn off the main power switch.
- If water leaks from the unit.  
Measure: Stop the operation.
- The operation switch does not work well.  
Measure: Turn off the power.
- If the user interface display  indicates the unit number, the operation lamp flashes and the malfunction code  
Measure: Notify your installer and report the malfunction code.

**If the system does not properly operate except for the above mentioned cases and none of the above mentioned malfunctions is evident, investigate the system according to the following procedures. If it is impossible to fix the problem yourself after checking all the above items, contact your dealer.**

**Let him know the symptoms, system name and model name (listed on the warranty card).**

1. If the system does not operate at all:
  - Check if there is no power failure.  
Wait unit power is restored. If power failure occurs during operation, the system automatically restarts immediately after the power supply is recovered.
  - Check if no fuse has blown or breaker has worked. Change the fuse or reset the breaker if necessary.

Turn the power on with the breaker switch in the off position.

Do not turn the power on with the breaker switch in the trip position.

(Contact your dealer.)

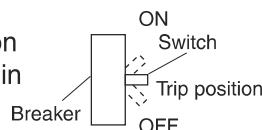

2. If the system goes into fan only operation, but as soon as it goes into cooling operation, the system stops:

- Check if air inlet or outlet of outdoor or indoor unit is not blocked by obstacles. Remove any obstacle and make it well-ventilated. Check if the user interface display shows  (time to clean the air filter).

Refer to “the operation manual of the indoor unit And clean the air filter”.

3. The system operates but cooling or heating is insufficient:
  - Check if air inlet or outlet of outdoor or indoor unit is not blocked by obstacles.
  - Remove any obstacle and make it well-ventilated.
  - Check if the air filter is not clogged (refer to “Maintenance” in the indoor unit manual).
  - Check the temperature setting.
  - Check the fan speed setting on your user interface.
  - Check for open doors or windows. Shut doors and windows to prevent wind from coming in.
  - Check if there are too many occupants in the room during cooling operation. Check if the heat source of the room is excessive.
  - Check if direct sunlight enters the room. Use curtains or blinds.
  - Check if the air flow angle is proper.

If the checking all above items, it is impossible to fix the problem your self, contact your installer and state the symptoms, the complete model name of the air conditioner (with manufacturing number if possible) and the installation date (possibly listed on the warranty card).

## 11. After-sales service and warranty

### 11.1 Warranty period

- This product includes a warranty card that was filled in by the dealer at the time of installation. The completed card has to be checked by the customer and stored carefully.
- If repairs to the air conditioner are necessary within the warranty period, contact your dealer and keep the warranty card at hand.

### 11.2. After-sales service

#### 11.2.1 Recommendations for maintenance and inspection

Since dust collects when using the unit for several years, performance of the unit will deteriorate to some extent. As taking apart and cleaning interiors of units requires technical expertise and in order to ensure the best possible maintenance of your units, we recommend to enter into a maintenance and inspection contract on top of normal maintenance activities. Our network of dealers has access to a permanent stock of essential components in order to keep your air conditioner in operation as long as possible. Contact your dealer for more information.



**When asking your dealer for an intervention, always state :**

- The complete model name of the air conditioner.
- The manufacturing number (stated on the name plate of the unit).
- The installation date.
- The symptoms or malfunction and details of the defect.

**⚠ WARNING**

- Do not modify, disassemble, remove, reinstall or repair the unit yourself as incorrect dismantling or installation may cause an electric shock or fire. Contact your dealer.
- In case of accidental refrigerant leaks, make sure there are no naked flames. The refrigerant itself is entirely safe, non-toxic and non-combustible, but it will generate toxic gas when it accidentally leaks into a room where combustible air from fan heaters, gas cookers, etc. is present. Always have qualified service personnel confirm that the point of leakage has been repaired or corrected before resuming operation.
- Do not remove or reinstall the unit by yourself. Incorrect installation may cause electrical shock or fire. Contact your dealer.

**11.2.2 Recommended inspection and maintenance cycles**

Be aware that the mentioned maintenance and replacement cycles do not relate to the warranty period of the components.

Table 1 assumes the following conditions of use:

- Normal use without frequent starting and stopping of the unit.  
Depending on the model, we recommend not starting and stopping the machine more than 6 times/hour.
- Operation of the unit is assumed to be 10 hours/day and 2,500 hours/year.

Table 1: “Inspection Cycle” and “Maintenance Cycle” list

Component	Inspection cycle	Maintenance cycle (replacements and/or repairs)
Electric motor (fan, damper, etc.)	1 year	20,000 hours
PCB boards		25,000 hours
Heat exchanger		5 years
Sensor (thermistor, etc.)		5 years
User interface and switches		25,000 hours
Drain pan		8 years
Expansion valve		20,000 hours
Electromagnetic valve		20,000 hours

**⚠ NOTICE**

- 1 Table 1 indicates main components. Refer to your maintenance and inspection contract for more details.
- 2 Table 1 indicates recommended intervals of maintenance cycles. However, in order to keep the unit operational as long as possible, maintenance work may be required sooner. Recommended intervals can be used for appropriate maintenance design in terms of budgeting maintenance and inspection fees. Depending on the content of the maintenance and inspection contract, inspection and maintenance cycles may in reality be shorter than listed.

**11.3 Shortening of “maintenance cycle” and “replacement cycle” needs to be considered in following situations**

**The unit is used in locations where:**

- Heat and humidity fluctuate out of the ordinary.
- Power fluctuation is high (voltage, frequency, wave distortion, etc.) (the unit cannot be used if power fluctuation is outside the allowable range).
- Bumps and vibrations are frequent.
- Dust, salt, harmful gas or oil mist such as sulphurous acid and hydrogen sulfide may be present in the air.
- The machine is started and stopped frequently or operation time is long (sites with 24 hour air conditioning).

Recommended replacement cycle of wear parts  
Table 2: “Replacement Cycle” list

Component	Inspection cycle	Maintenance cycle (replacements and/or repairs)
Air filter	1 year	5 years
High efficiency filter (Optional accessory)		1 year
Fuse		10 years
Crankcase heater		8 years

**⚠ NOTICE**

- Table 2: “Replacement Cycle” list indicates main components. Refer to your maintenance and inspection contract for more details.
- Table 2: “Replacement Cycle” list indicates recommended intervals of replacement cycles. However, in order to keep the unit operational as long as possible maintenance work may be required sooner. Recommended intervals can be used for appropriate maintenance design in terms of budgeting maintenance and inspection fees. Contact your dealer for details.



## INFORMATION

Damage due to taking apart or cleaning interiors of units by anyone other than our authorized dealers may not be included in the warranty.

### Moving and discarding the unit

- Contact your dealer for removing and reinstalling the total unit. Moving units requires technical expertise.
- This unit uses hydrofluorocarbon. Contact your dealer when discarding this unit. It is required by law to collect, transport and discard the refrigerant in accordance with the “hydrofluorocarbon collection and destruction” regulations.

### 11.4 Malfunction codes

In case a malfunction code appears on the indoor unit user interface display, contact your installer and inform the malfunction code, the unit type and serial number (you can find this information on the nameplate of the unit).

For your reference, a list with malfunction codes is provided. You can, depending on the level of the malfunction code, reset the code by pushing the ON/OFF button. If not, ask your installer for advice.

Malfunction code	Contents
Main code	
R0	External protection device was activated
R1	EEPROM failure (indoor)
R3	Drain system malfunction (indoor)
R6	Fan motor malfunction (indoor)
R7	Swing flap motor malfunction (indoor)
R9	Expansion valve malfunction (indoor)
RF	Drain malfunction (indoor unit)
RH	Filter dust chamber malfunction (indoor)
RJ	Capacity setting malfunction (indoor)
C1	Transmission malfunction between main PCB and sub PCB (indoor)
C4	Heat exchanger thermistor malfunction (indoor; liquid)
C5	Heat exchanger thermistor malfunction (indoor; gas)
C9	Suction air thermistor malfunction (indoor)
CR	Discharge air thermistor malfunction (indoor)
CE	Movement detector or floor temperature sensor malfunction (indoor)
CJ	User interface thermistor malfunction (indoor)
E1	PCB malfunction (outdoor)
E2	Current leakage detector was activated (outdoor)
E3	High pressure switch was activated
E4	Low pressure malfunction (outdoor)
E5	Compressor lock detection (outdoor)
E7	Fan motor malfunction (outdoor)
E9	Electronic expansion valve malfunction (outdoor)
F3	Discharge temperature malfunction (outdoor)
F4	Abnormal suction temperature (outdoor)

Malfunction code	Contents
Main code	
F5	Refrigerant overcharge detection
H3	High pressure switch malfunction
H4	Low pressure switch malfunction
H7	Fan motor trouble (outdoor)
H9	Ambient temperature sensor malfunction (outdoor)
J1	Pressure sensor malfunction
J2	Current sensor malfunction
J3	Discharge temperature sensor malfunction (outdoor)
J4	Heat exchanger gas temperature sensor malfunction (outdoor)
J5	Suction temperature sensor malfunction (outdoor)
J6	De-icing temperature sensor malfunction (outdoor)
J7	Liquid temperature sensor (after subcool HE) malfunction (outdoor)
J8	Liquid temperature sensor (coil) malfunction (outdoor)
J9	Gas temperature sensor (after subcool HE) malfunction (outdoor)
JR	High pressure sensor malfunction (S1NPH)
JE	Low pressure sensor malfunction (S1NPL)
L1	INV PCB abnormal
L4	Fin temperature abnormal
L5	Inverter PCB faulty
L8	Compressor over current detected
L9	Compressor lock (startup)
LC	Transmission outdoor unit - inverter: INV transmission trouble
P1	INV unbalanced power supply voltage
P2	Autocharge operation related
P4	Fin thermistor malfunction
P8	Autocharge operation related
P9	Autocharge operation related
PE	Autocharge operation related
PJ	Capacity setting malfunction (outdoor)
U0	Abnormal low pressure drop, faulty expansion valve
U1	Open phase
U2	INV voltage power shortage
U3	System test run not yet executed
U4	Faulty wiring indoor/outdoor
U5	Abnormal user interface - indoor communication
U7	Faulty wiring to Q1/Q2
U8	Abnormal main-sub user interface communication
U9	System mismatch. Wrong type of indoor units combined. Indoor unit malfunction.
UR	Connection malfunction over indoor units or type mismatch
UC	Centralized address duplication
UE	Malfunction in communication centralized control device - indoor unit
UF	Auto address malfunction (inconsistency)
UH	Auto address malfunction (inconsistency)



# ***DAIKIN AIRCONDITIONING INDIA PVT. LTD.***

Head office:

12th Floor, Building No.9,Tower A,

DLF Cyber City, DLF Phase-III,

Gurgaon-122 002, Haryana, India

[www.daikinindia.com](http://www.daikinindia.com)