



**COMMERCIAL REFRIGERATION EVAPORATING UNIT
(UNIT COOLER)
OPERATION AND
INSTALLATION MANUAL**

→ Medium Temperature (MT) Units

CRE1M400ARV/ASV16
CRE2M600ARV/ASV16
CRE2M800ARV/ASV16
CRE3M980ARV/ASV16
CRE3M1400ARV/ASV16
CRE/U2M1700ASY16
CRE/U2M2200ASY16
CRE/U2M2800ASY16
CRE2M1200ASY16
CRE2M1600ASY16
CRE/U2M2100ASY16

CRE1M400BRV/BSV16
CRE2M600BRV/BSV16
CRE2M800BRV/BSV16
CRE3M980BRV/BSV16
CRE3M1400BRV/BSV16
CRE/U2M1700BSY16
CRE/U2M2200BSY16
CRE/U2M2800BSY16
CRE3M600BSV16
CRE3M800BSV16

→ Low Temperature (LT) Units

CRE1L200ARV/ASV16
CRE2L320ARV/ASV16
CRE2L400ARV/ASV16
CRE3L480ARV/ASV16
CRE3L600ARV/ASV16
CRE/U2L0900ASY16
CRE/U2L1400ASY16
CRE/U2L1800ASY16
CRE2L650ASY16
CRE2L1100ASY16

CRE1L200BRV/BSV16
CRE2L320BRV/BSV16
CRE2L400BRV/BSV16
CRE3L480BRV/BSV16
CRE3L600BRV/BSV16
CRE/U2L0900BSY16
CRE/U2L1400BSY16
CRE/U2L1800BSY16
CRE2L1300ASY16

→ High Medium Temperature (HMT) Units

CRE1HM150ARV/ASV16
CRE2HM800ARV/ASV16
CRE1H400ASV16
CRE2H1400ASV16
CRE2H2400ASV16

CRE1HM150BRV/BSV16
CRE2HM800BRV/BSV16
CRE3H900ASV16
CRE3H1000ASV16

3P647989-1-KA G

TABLE OF CONTENTS

	Page
1. Unit Information and Dimensions	
1.1 Nomenclature	3
1.2 Product Features	3
1.3 Unit Dimension	4
1.4 General	4
2. Specification	
2.1 General	5
3. Unit Location and Mounting	
3.1 Unit Location	10
3.2 Mounting	10
4. Piping Installation	
4.1 Refrigerant Piping	11
4.2 Vacuum & Leak Test	11
4.3 Drain Pipe	11
4.4 Superheat	11
5. Electrical	
5.1 Field Wiring	12
5.2 Earth Wiring	12
5.3 Wiring Diagram	13
6. Start up	
6.1 Pre-start up	16
6.2 Operation Checkout	16
7. Preventative Maintenance	16
8. Troubleshooting chart	17
9. E-Waste Guideline	18



1 UNIT INFORMATION

1.1 *Nomenclature*

C	R	E	2	L	0	4	0	0	A	R	V	1	6
1	2	3	4	5	6	7	8	9	10	11	12	13	14

Digit	Description
1 & 2	CR – Commercial Refrigeration
3	E - Single Circuit / U - Double Circuit
4	2 - No. of Fans in the unit Eg: 1, 2 or 3 Nos.
5	M - Medium Temperature L - Low Temperature HMT - High Medium Temperature
6, 7, 8 & 9	0400 : Cooling Capacity in kW Eg: 400/100 = 4kW, (R404A)
10	A-GI body B-SS body
11	R - EBM S - HICOOL
12 & 13	Power supply: V1-1ph/50Hz/230V & Y1-3ph/50Hz/415V
14	6 - India

Medium temperature application for room temperature of 0 ~ 15 °C

Low temperature application for room temperature of -25 ~ 5 °C

High medium temperature application for room temperature of 0 ~ 20 °C

1.2 *Product features*

- Can be used with refrigerants R404A and R32 (for HMT unit only).
- Powder coated galvanized casing. (A series)
- IP44/IP54 Axial fan with moisture proof protected and built in thermal overload.
- Slots for defrosting using electrical heaters.
- Pre-fixed wiring to fan motor.
- Pre-installed thermal expansion valve.
- Available in High Medium temperature, Medium Temperature and Low Temperature series.
- ARV/ASV/ASY series with GI casing and BRV/BSV/BSY series with Stainless Steel.

1.3 Unit Dimension

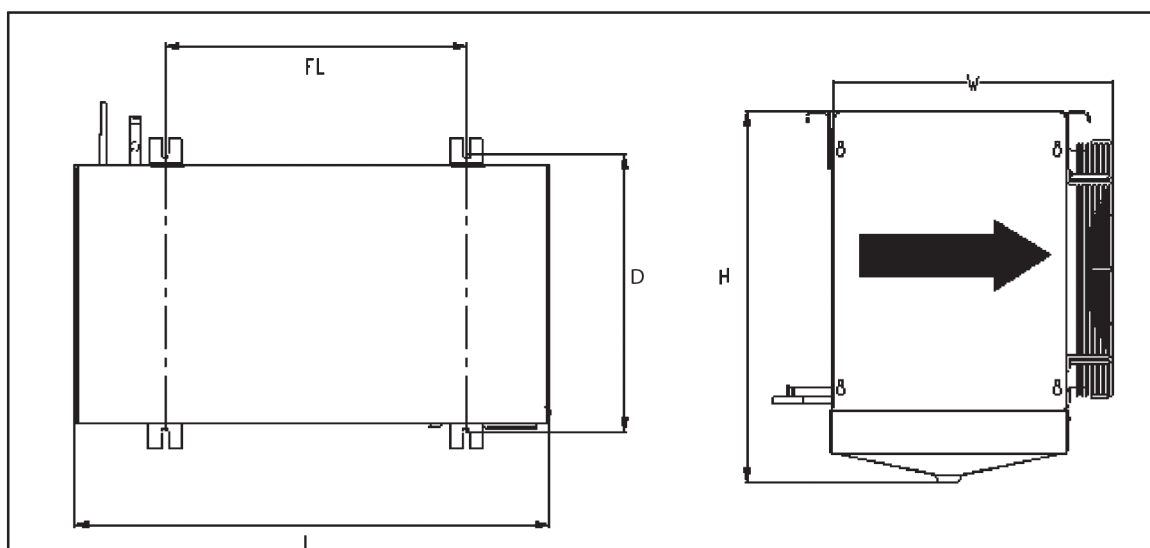

MODELS	L(mm)	FL(mm)	W(mm)	H(mm)	D(mm)
CRE1HM150ARV/ASV16, CRE1L200ARV16/ASV16, CRE1M400ARV16/ASV16, CRE1H400ASV16	745	489	560	515	385
CRE2M600/800ARV16, CRE2M600/800ASV16 CRE2L320/400ARV16, CRE2L320/400ASV16 CRE2HM800ARV/ASV16	1205	944	560	515	385
CRE3M980/1400ARV16, CRE3M980/1400ASV16 CRE3L480/600ARV16, CRE3L480/600ASV16, CRE3M600/800ASV16, CRE3H900/1000ASV16	1665	1399	560	515	385
CRE/CRU2M2200ASY16, CRE/CRU2M1700ASY16 CRE/CRU2M2800ASY16 CRE/CRU2L900ASY16, CRE/CRU2L1400ASY16 CRE/CRU2L1800ASY16	2400	2035	555	720	446
CRE2M1200/1600ASY16 ,CRE/CRU2M2100ASY16 CRE2L650/1100/1300ASY16 CRE2H1400ASY16 , CRU2H2400ASY16	1665	1400	560	715	386.5

Note : Same dimensions should be referred for respective BRV/BSY/BSV series units.

1.4 General

Upon receiving the products, please ensure:

- The pipework should show no signs of damage.
- The fan/ fan motor terminals box are not cracked or showing signs of obvious damage.
- The electrical screw terminals in control panels and motor mountings should be checked for security.



2 SPECIFICATIONS

2.1 General

(a) Medium Temperature

	Model	CRE1M400ARV16	CRE2M600ARV16	CRE2M800ARV16	CRE3M980ARV16	CRE3M1400ARV16
General	Size (L x W x H) (mm x mm x mm)	745 x 560 x 515	1205 x 560 x 515	1205 x 560 x 515	1665 x 560 x 515	1665 x 560 x 515
	Weight (kg)	27	34	43	51	62
	Room Temperature (°C)	0~15	0~15	0~15	0~15	0~15
	Refrigerant	R404A	R404A	R404A/R32	R404A	R404A
	Power Supply	230V/1Ph/50Hz	230V/1Ph/50Hz	230V/1Ph/50Hz	230V/1Ph/50Hz	230V/1Ph/50Hz
Fan	Fan Size (mm x Qty)	315 x 1	315 x 2	315 x 2	315 x 3	315 x 3
	Fan Speed (rpm)	1350	1350	1350	1350	1350
Finishing	Casing [#]	GI	GI	GI	GI	GI
	Color	Ivory White	Ivory White	Ivory White	Ivory White	Ivory White
Connection Pipe Size (OD)	Outlet (mm)	12.7	15.88	22.22	22.22	28.56
	Inlet (mm)	12.7	12.7	15.88	15.88	15.88

: For BRV series, casing will be of stainless steel. Rest of the specifications should be considered same as that in respective BSV series as given in above table.

	Model	CRE2M1200ASY16	CRE2M1600ASY16	CRE2M2100ASY16	CRU2M2100ASY16	CRE3M600ASV16	CRE3M800ASV16
General	Size (L x W x H) (mm x mm x mm)	1665 x 560 x 715	1665 x 560 x 715	1665 x 560 x 715	1665 x 560 x 715	1665 x 560 x 515	1665 x 560 x 515
	Weight (kg)	77	87	93	94	56	59
	Room Temperature (°C)	0~15	0~15	0~15	0~15	0~15	0~15
	Refrigerant	R404A	R404A	R404A	R404A	R404A	R404A
	Power Supply	415V/3Ph/50Hz	415V/3Ph/50Hz	415V/3Ph/50Hz	415V/3Ph/50Hz	230V/1Ph/50Hz	230V/1Ph/50Hz
Fan	Fan Size (mm x Qty)	550 x 2	550 x 2	550 x 2	550 x 2	350 x 2	350 x 2
	Fan Speed (rpm)	1400	1400	1400	1400	1380	1380
Finishing	Casing [#]	GI	GI	GI	GI	GI	GI
	Color	Ivory White	Ivory White	Ivory White	Ivory White	Ivory White	Ivory White
Connection Pipe Size (OD)	Outlet (mm)	22.22	28.56	28.56	22.22	19.05	22.22
	Inlet (mm)	12.7	15.9	15.9	12.7	12.7	12.7

: For BSV/BSY series, casing will be of stainless steel. Rest of the specifications should be considered same as that in respective ASV / ASY series as given in above table.

	Model	CRE1M400ASV16	CRE2M600ASV16	CRE2M800ASV16	CRE3M980ASV16	CRE3M1400ASV16
General	Size (L x W x H) (mm x mm x mm)	745 x 560 x 515	1205 x 560 x 515	1205 x 560 x 515	1665 x 560 x 515	1665 x 560 x 515
	Weight (kg)	35	52	61	67	78
	Room Temperature (°C)	0~15	0~15	0~15	0~15	0~15
	Refrigerant	R404A	R404A	R404A/R32	R404A	R404A
	Power Supply	230V/1Ph/50Hz	230V/1Ph/50Hz	230V/1Ph/50Hz	230V/1Ph/50Hz	230V/1Ph/50Hz
Fan	Fan Size (mm x Qty)	350 x 1	350 x 2	350 x 2	350 x 3	350 x 3
	Fan Speed (rpm)	1380	1380	1380	1380	1380
Finishing	Casing [#]	GI	GI	GI	GI	GI
	Color	Ivory White	Ivory White	Ivory White	Ivory White	Ivory White
Connection Pipe Size (OD)	Outlet (mm)	12.7	15.88	22.22	22.22	28.56
	Inlet (mm)	12.7	12.7	15.88	15.88	15.88

: For BSV series, casing will be of stainless steel. Rest of the specifications should be considered same as that in respective ASV series as given in above table.

	Model	CRE2M1700ASY16	CRE2M2200ASY16	CRE2M2800ASY16	CRU2M1700ASY16	CRU2M2200ASY16	CRU2M2800ASY16
General	Size (L x W x H) (mm x mm x mm)	2400x555x720	2400x555x720	2400x555x720	2400x555x720	2400x555x720	2400x555x720
	Weight (kg)	119	140	155	119	140	155
	Room Temperature (°C)	0~15	0~15	0~15	0~15	0~15	0~15
	Refrigerant	R404A	R404A	R404A	R404A	R404A	R404A
	Power Supply	415V/3Ph/50Hz	415V/3Ph/50Hz	415V/3Ph/50Hz	415V/3Ph/50Hz	415V/3Ph/50Hz	415V/3Ph/50Hz
Fan	Fan Size (mm x Qty)	550 x 2	550 x 2	550 x 2	550 x 2	550 x 2	550 x 2
	Fan Speed (rpm)	1400	1400	1400	1400	1400	1400
Finishing	Casing [#]	GI	GI	GI	GI	GI	GI
	Color	Ivory White	Ivory White	Ivory White	Ivory White	Ivory White	Ivory White
Connection Pipe Size (OD)	Outlet (mm)	28.56	28.56	34.92	28.56	28.56	34.92
	Inlet (mm)	15.88	15.88	15.88	12.7	12.7	15.88

: For BSY series, casing will be of stainless steel. Rest of the specifications should be considered same as that in respective ASY series as given in above table.



(b) Low Temperature

	Model	CRE1L200ARV16	CRE2L320ARV16	CRE2L400ARV16	CRE3L480ARV16	CRE3L600ARV16
General	Size (L x W x H) (mm x mm x mm)	745 x 560 x 515	1205 x 560 x 515	1205 x 560 x 515	1665 x 560 x 515	1665 x 560 x 515
	Weight (kg)	27	34	43	51	62
	Room Temperature (°C)	-25 ~ 5	-25 ~ 5	-25 ~ 5	-25 ~ 5	-25 ~ 5
	Refrigerant	R404A	R404A	R404A	R404A	R404A
	Power Supply	230V/1Ph/50Hz	230V/1Ph/50Hz	230V/1Ph/50Hz	230V/1Ph/50Hz	230V/1Ph/50Hz
Fan	Fan Size (mm x Qty)	315 x 1	315 x 2	315 x 2	315 x 3	315 x 3
	Fan Speed (rpm)	1350	1350	1350	1350	1350
Heater	Power (W) x Qty	600x3	800x3	800x3	1200x3	1200x3
	Total Power Consumption (W)	1800	2400	2400	3600	3600
Finishing	Casing[#]	GI	GI	GI	GI	GI
	Color	Ivory White	Ivory White	Ivory White	Ivory White	Ivory White
Connection Pipe Size (OD)	Outlet (mm)	15.88	15.88	22.22	22.22	28.56
	Inlet (mm)	12.7	12.7	12.7	12.7	15.88

: For BRV series, casing will be of stainless steel. Rest of the specifications should be considered same as that in respective ARV series as given in above table.

	Model	CRE1L200ASV16	CRE2L320ASV16	CRE2L400ASV16	CRE3L480ASV16	CRE3L600ASV16
General	Size (L x W x H) (mm x mm x mm)	745 x 560 x 515	1205 x 560 x 515	1205 x 560 x 515	1665 x 560 x 515	1665 x 560 x 515
	Weight (kg)	35	52	61	67	78
	Room Temperature (°C)	-25 ~ 5	-25 ~ 5	-25 ~ 5	-25 ~ 5	-25 ~ 5
	Refrigerant	R404A	R404A	R404A	R404A	R404A
	Power Supply	230V/1Ph/50Hz	230V/1Ph/50Hz	230V/1Ph/50Hz	230V/1Ph/50Hz	230V/1Ph/50Hz
Fan	Fan Size (mm x Qty)	350 x 1	350 x 2	350 x 2	350 x 3	350 x 3
	Fan Speed (rpm)	1380	1380	1380	1380	1380
Heater	Power (W) x Qty	600x3	800x3	800x3	1200x3	1200x3
	Total Power Consumption (W)	1800	2400	2400	3600	3600
Finishing	Casing[#]	GI	GI	GI	GI	GI
	Color	Ivory White	Ivory White	Ivory White	Ivory White	Ivory White
Connection Pipe Size (OD)	Outlet (mm)	15.88	15.88	22.22	22.22	28.56
	Inlet (mm)	12.7	12.7	12.7	12.7	15.88

: For BSV series, casing will be of stainless steel. Rest of the specifications should be considered same as that in respective ASV series as given in above table.



	Model	CRE2L0900ASY16	CRE2L1400ASY16	CRE2L1800ASY16	CRU2L0900ASY16	CRU2L1400ASY16	CRU2L1800ASY16
General	Size (L x W x H) (mm x mm x mm)	2400x555x720	2400x555x720	2400x555x720	2400x555x720	2400x555x720	2400x555x720
	Weight (kg)	119	140	155	119	140	155
	Room Temperature (°C)	-25 ~ 5	-25 ~ 5	-25 ~ 5	-25 ~ 5	-25 ~ 5	-25 ~ 5
	Refrigerant	R404A	R404A	R404A	R404A	R404A	R404A
	Power Supply	415V/3Ph/50Hz	415V/3Ph/50Hz	415V/3Ph/50Hz	415V/3Ph/50Hz	415V/3Ph/50Hz	415V/3Ph/50Hz
Fan	Fan Size (mm x Qty)	550 x 2	550 x 2	550 x 2	550 x 2	550 x 2	550 x 2
	Fan Speed (rpm)	1400	1400	1400	1400	1400	1400
Heater	Power (W) x Qty	1000x5	1000x5	1000x7	1000x5	1000x5	1000x7
	Total Power Consumption (W)	5000	5000	7000	5000	5000	7000
Finishing	Casing[#]	GI	GI	GI	GI	GI	GI
	Color	Ivory White	Ivory White	Ivory White	Ivory White	Ivory White	Ivory White
Connection Pipe Size (OD)	Outlet (mm)	28.56	28.56	34.92	28.56	28.56	34.92
	Inlet (mm)	15-88	15-88	15-88	12.7	12.7	15-88

: For BSY series, casing will be of stainless steel. Rest of the specifications should be considered same as that in respective ASY series as given in above table.

	Model	CRE2L650ASY16	CRE2L1100ASY16	CRE2L1300ASY16
General	Size (L x W x H) (mm x mm x mm)	1665 x 560 x 715	1665 x 560 x 715	1665 x 560 x 715
	Weight (kg)	83	94	105
	Room Temperature (°C)	-25 ~ 5	-25 ~ 5	-25 ~ 5
	Refrigerant	R404A	R404A	R404A
	Power Supply	415V/3Ph/50Hz	415V/3Ph/50Hz	415V/3Ph/50Hz
Fan	Fan Size (mm x Qty)	550 x 2	550 x 2	550 x 2
	Fan Speed (rpm)	1400	1400	1400
Heater	Power (W) x Qty	1200 x 6	1200 x 6	1200 x 8
	Total Power Consumption (W)	7200	7200	9600
Finishing	Casing[#]	GI	GI	GI
	Color	Ivory White	Ivory White	Ivory White
Connection Pipe Size (OD)	Outlet (mm)	28.56	28.56	28.56
	Inlet (mm)	15.9	15.9	15.9

: For BSY series, casing will be of stainless steel. Rest of the specifications should be considered same as that in respective ASY series as given in above table.



(c) High Medium Temperature (R32 and R410A)

	Model	CRE1HM150ARV16	CRE1HM150ASV16	CRE2HM800ARV16	CRE2HM800ASV16
General	Size (L x W x H) (mm x mm x mm)	745 x 560 x 515	1205 x 560 x 515	1205 x 560 x 515	1665 x 560 x 515
	Weight (kg)	27	35	43	61
	Room Temperature (°C)	0-20	0~20	0~20	0~20
	Refrigerant	R32	R32	R32	R32
	Power Supply	230V/1Ph/50Hz	230V/1Ph/50Hz	230V/1Ph/50Hz	230V/1Ph/50Hz
Fan	Fan Size (mm x Qty)	315 x 1	350 x 1	315 x 2	350 x 2
	Fan Speed (rpm)	1350	1380	1350	1380
Finishing	Casing#	GI	GI	GI	GI
	Color	Ivory White	Ivory White	Ivory White	Ivory White
Connection Pipe Size (OD)	Outlet (mm)	15.88	15.88	22.22	22.22
	Inlet (mm)	12.7	12.7	15.88	15.88

#: For BRV/BSV series, casing will be of stainless steel. Rest of the specifications should be considered same as that in respective ARV/ASV series as given in above table.

	Model	CRE1H400ASV16	CRE2H1400ASY16	CRU2H2400ASY16	CRE3H900ASV16	CRE3H1000ASV16
General	Size (L x W x H) (mm x mm x mm)	745 x 560 x 515	1665 x 560 x 715	1665 x 560 x 715	1665 x 560 x 515	1665 x 560 x 515
	Weight (kg)	28	74	84	56	58
	Room Temperature (°C)	0~20	0~20	0~20	0-20	0~20
	Refrigerant	R32	R410A	R32	R32	R410A
	Power Supply	230V/1Ph/50Hz	415V/3Ph/50Hz	415V/3Ph/50Hz	230V/1Ph/50Hz	230V/1Ph/50Hz
Fan	Fan Size (mm x Qty)	350 x 1	550 x 2	550 x 2	350 x 3	350 x 3
	Fan Speed (rpm)	1380	1400	1400	1380	1380
Finishing	Casing#	GI	GI	GI	GI	GI
	Color	Ivory White	Ivory White	Ivory White	Ivory White	Ivory White
Connection Pipe Size (OD)	Outlet (mm)	12.7	22.22	19.04	19.05	22.22
	Inlet (mm)	9.52	12.7	12.7	12.7	12.7

#: For BSV/BSY series, casing will be of stainless steel. Rest of the specifications should be considered same as that in respective ASV/ASY series as given in above table.

3 UNIT LOCATION AND MOUNTING

3.1 *Unit Location*

Unit coolers must be located at places that provide good air circulation, otherwise the performances of the unit cooler could be compromised. For best performance it is desirable to arrange the air discharge blowing toward the door to minimize the entrance of warm moist air when door is open. Light fixtures, shelving and product boxes must be located in a manner whereby they do not block the air intake and air discharge from the unit cooler.

Side clearance should be reserved so that service work can be carried out.

IMPORTANT:

The coil face must be located a minimum of $0.6 \times H$ " from walls to assure unrestricted air intake.

3.2 *Mounting*

Evaporating units come with mounting holes that can be fixed with the use of M8 or M10 bolts and nuts. The unit must be installed in a level manner, to ensure water condensation can be properly drained out.

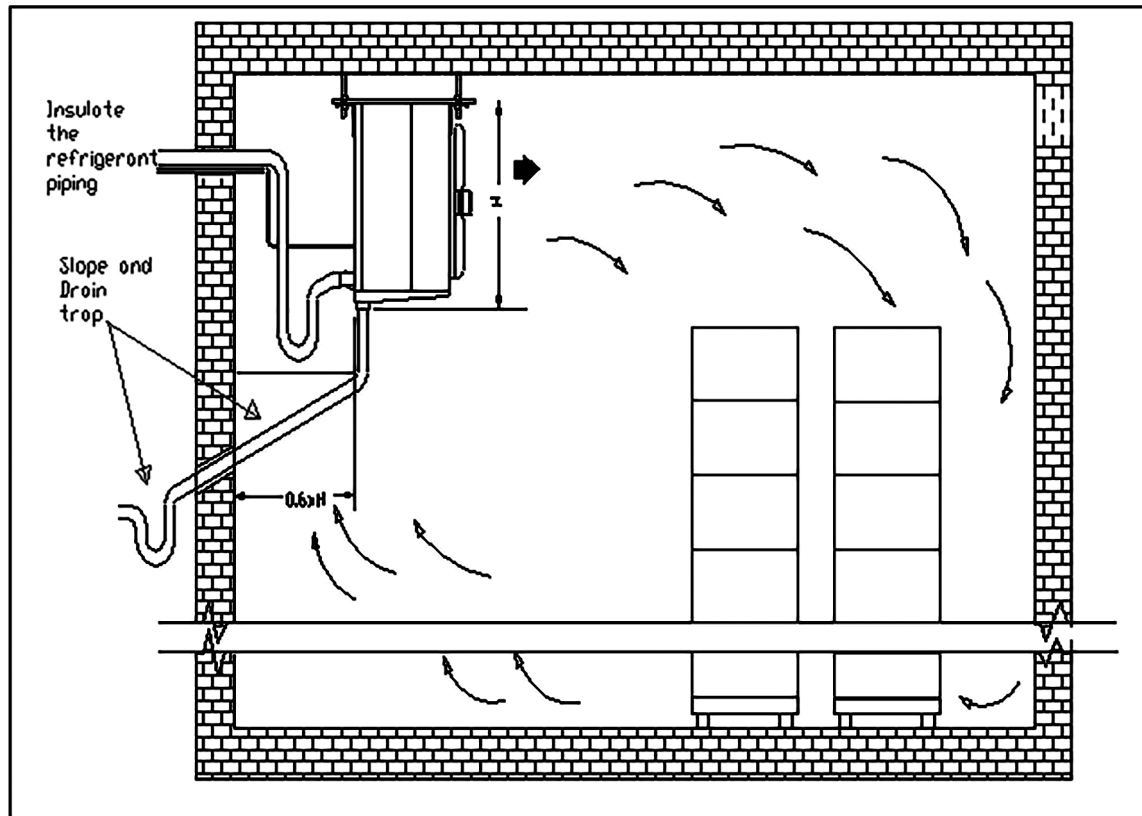



4 PIPING INSTALLATION

4.1 *Refrigerant pipe connection*

Refrigerant pipe connections should be installed in accordance with all the applicable codes and using good refrigeration practices. Suction lines should be properly insulated to prevent sweating and ensure only superheated vapor is returned to compressor suction. During brazing, the system should be purged with nitrogen first, to prevent oxidation.

4.2 *Vacuum and leak test*

When all refrigeration piping connections had been completed, the entire system must be tested for leaks and then vacuum. Refer to the instruction manual provided by the coupled condensing unit for the leak test and vacuum test information.

4.3 *Drain pipe*

Installing a trap is required for trouble free operation. If evaporating unit is operated without the drain trap, warm air with higher temperature will be drawn from outside to the cold room. Thus, warm air will significantly reduce the cooling capacity and may lead to ice formation in the drain pan.

If the temperature surrounding the drain line and trap is below freezing (0°C), it must be wrapped with a drain line heater and insulation until the pipe comes out of the wall of cool room. Make sure the drain line is clear to prevent drain line plugged and overflow.

4.4 *Superheat*

Check suction superheat and adjust expansion valve to prevent liquid flood back to the compressor. Recommended 5K to 20 K for suction superheat.

**Remarks: Expansion valve is pre-fitted in the units.

5 ELECTRICAL

5.1 *Field wiring*

Field wiring should comply with local codes. The power supply voltage, phase and frequency must match what is shown on the evaporating unit data plate.

The wiring diagram for each unit is located inside the panel door of the control box.

The unit must be grounded.

Heater slots available for defrost heaters.

It is advised to install thermal fuse (supplied by site) when the unit is installed with defrost heater.

The location of the thermal fuse should be appropriately located to have safety cut off when the heater is overheated.



5.2 *Earth Wiring*

Units must be earthed and no maintenance work should be attempted prior to disconnecting the electrical supply. Installation of earth wire should be made to earth screw before connecting the live wires. The earth wire shall be slacked with longer length as shown in below diagram.

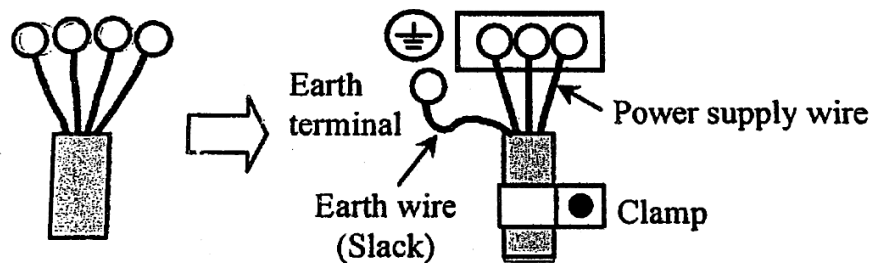

WARNING

Please check electrical safety (leakage current, withstand voltage, earth continuity) once heaters, fuses and timers are connected.

5.3 Wiring Diagram

REMARK : Heater is provided for low temperature models only.

- (a) CRE1M400ARV/ASV16 ; CRE1L200ARV/ASV16 ; CRE1M400BRV/BSV16
 CRE1L200BRV/BSV16; CRE1H400ASV16

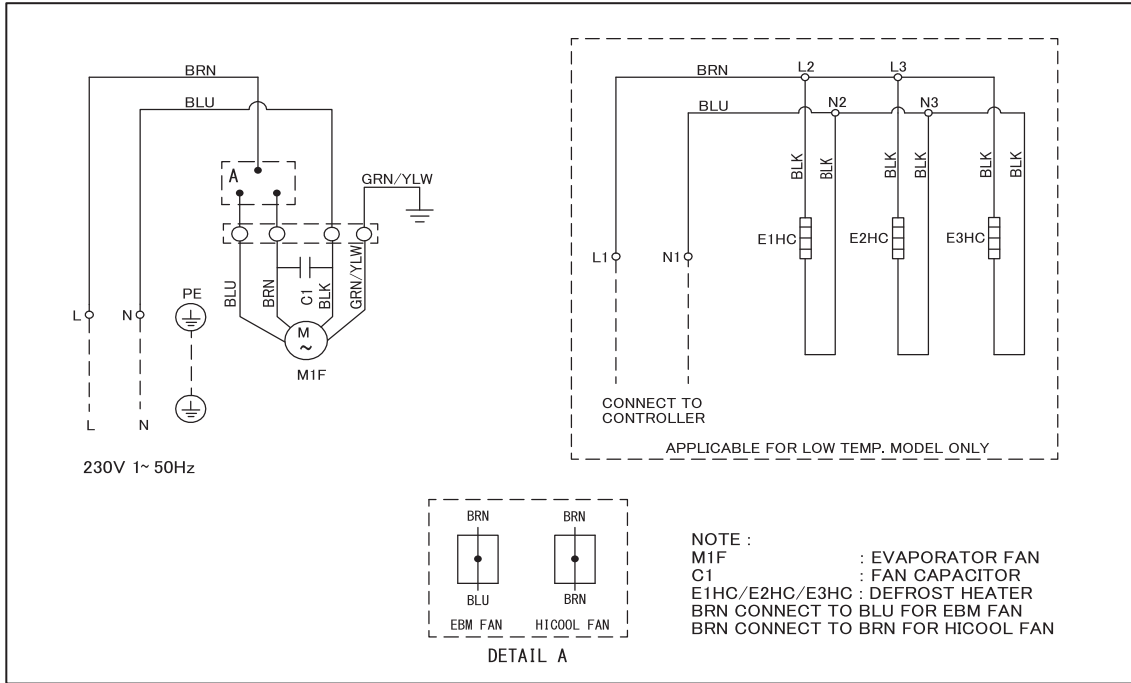

- (b) CRE2M600ARV/ASV16 ; CRE2M800ARV/ASV16 ; CRE2L320ARV/ASV16
 CRE2L400ARV/ASV16 ; CRE2M600BRV/BSV16 ; CRE2M800BRV/BSV16
 CRE2L320BRV/BSV16 ; CRE2L400BRV/BSV16

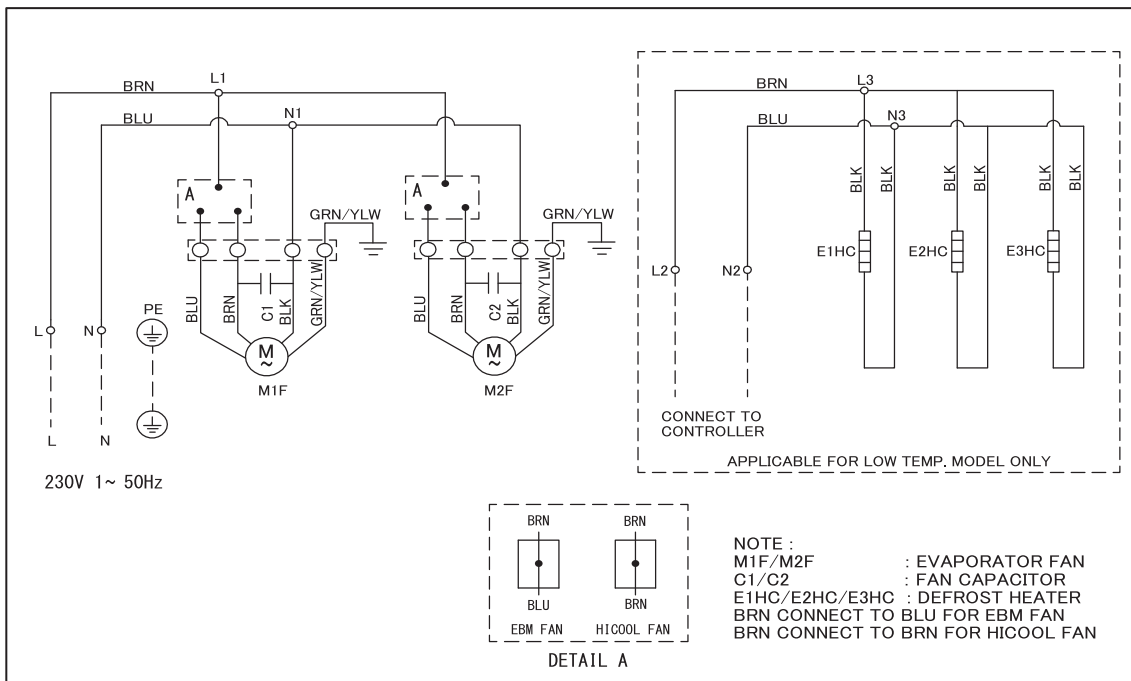

- (c) CRE3M980ARV/ASV16 ; CRE3M1400ARV/ASV16 ; CRE3L480ARV/ASV16
 CRE3L600ARV/ASV16 ; CRE3M980BRV/BSV16 ; CRE3M1400BRV/BSV16
 CRE3L480BRV/BSV16 ; CRE3L600BRV/BSV16
 CRE3M600ASV16 ; CRE3M800ASV16 ; CRE3H900ASV16 ; CRE3H1000ASV16

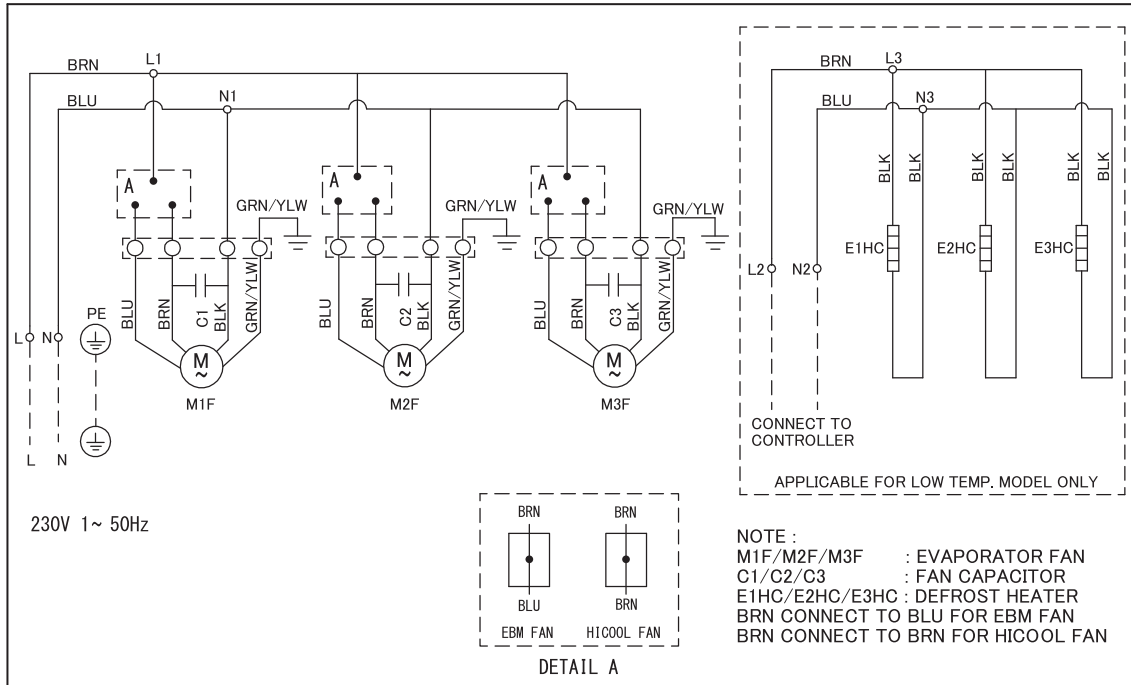

- (d) CRE/U2M1700ASY16; CRE/U2M2200ASY16; CRE/U2M2800ASY16; CRE/U2M1700BSY16,
 CRE/U2M2200BSY16; CRE/U2M2800BSY16; CRE/U2L0900ASY16; CRE/U2L1400ASY16,
 CRE/U2L1800ASY16; CRE/U2L0900BSY16; CRE/U2L1400BSY16; CRE/U2L1800BSY16
 CRE2M1200/1600/2100ASY16 ; CRU2M2100ASY16
 CRE2L650ASY16; CRE2L1100ASY16 ; CRE2H1400ASY16 ; CRU2H2400ASY16

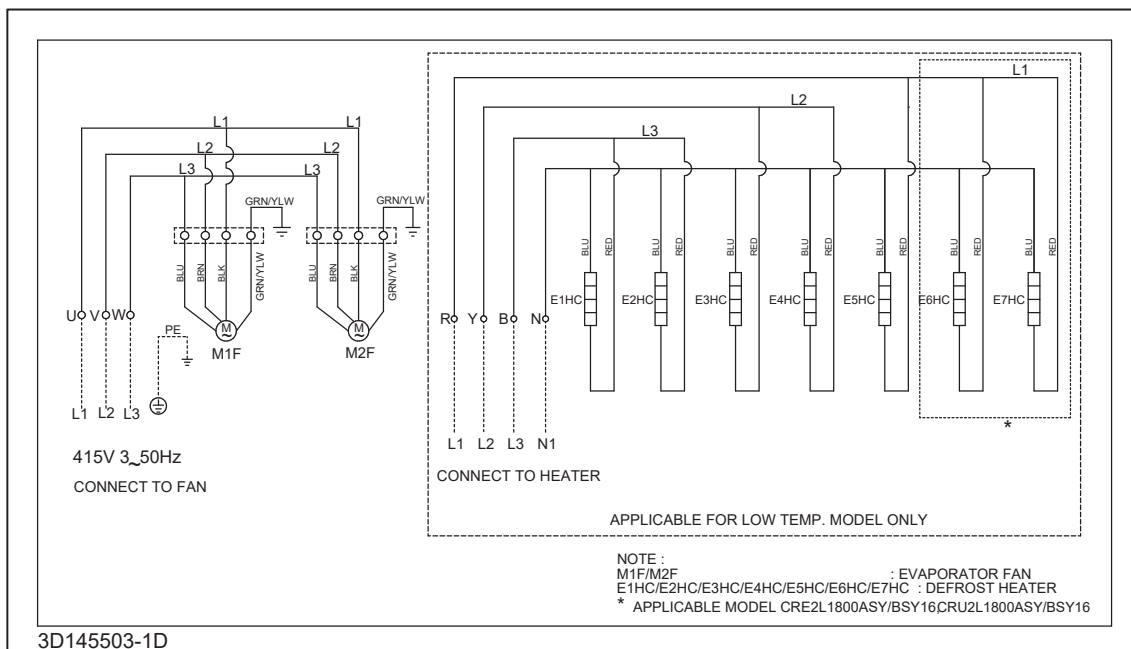

(e) CRE2L1300ASY16

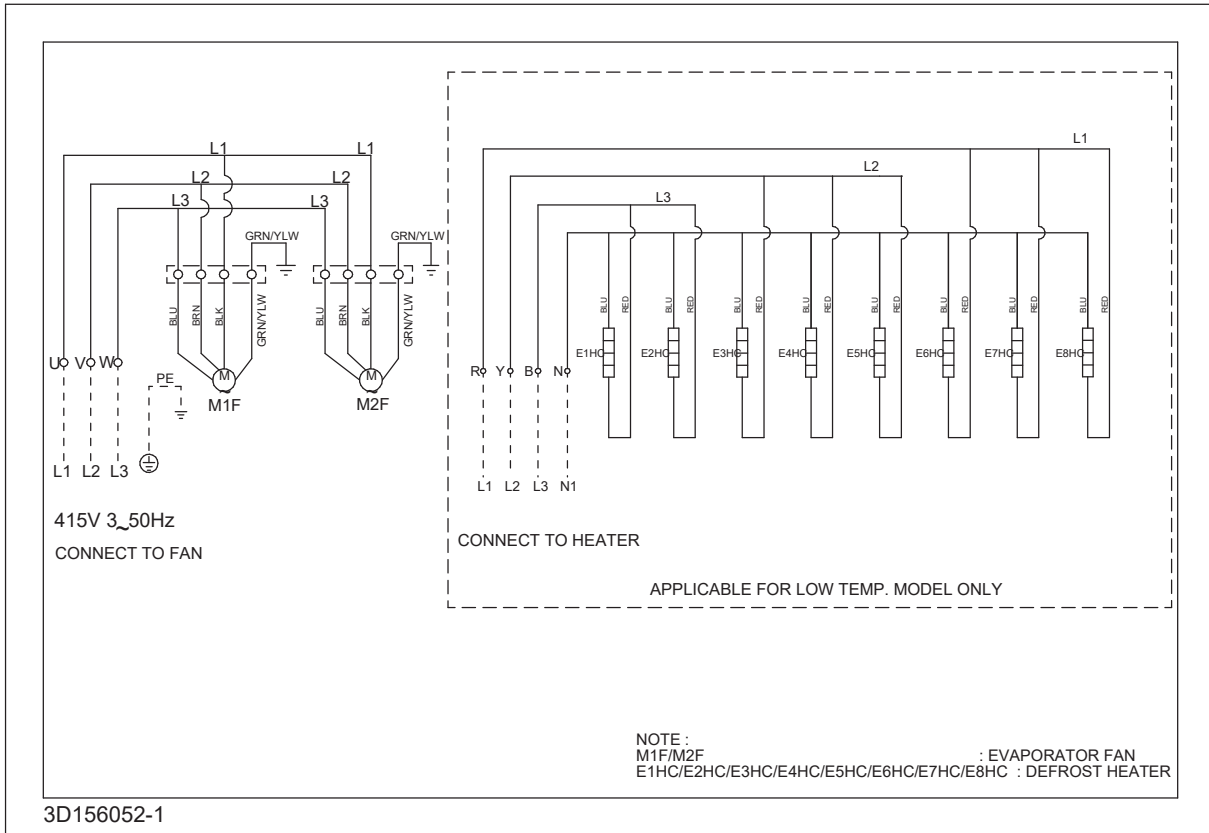



6 START UP

6.1 *Pre-start up*

After the installation is completed, a review of the following items should be performed before the system is placed into operation:

- Check electrical connections, fan motors, grills and all other fasteners for tightness. Be sure the thermostatic expansion valve bulb is properly located, strapped and insulated.
- With the system operating, check the supply voltage. It must be within +/- 10% of the voltage marked on the unit nameplate.

6.2 *Operation Checkout*

A defrost cycle is needed when the frost build up, frost impedes the airflow through the coil. The defrost requirements will vary on each installation and may change depending on the time of the year and other conditions.

WARNING

Please be aware that during electric defrost, the temperature of surrounding may rise dramatically. Kindly keep safe distance from the unit.

Check the drain line and make sure drain line is clear and unit is aligned in all positions to avoid overflow of condensation water.

7 PREVENTATIVE MAINTENANCE

A preventative maintenance schedule should be set up as soon as the evaporating unit is installed. The unit should be inspected periodically for proper operation and buildup of dirt.

1. Inspect and clean the drain pan to ensure there is no blockage. The drain pan should be cleaned regularly with warm water and neutral detergent.

WARNING: All power must be disconnected before cleaning.

2. The cabinet, fans and guards can be cleaned with water and neutral detergent. Do not clean using water jet.
3. The evaporator coil should be checked once a month for proper defrosting. Many variables affect coil frosting such as room temperature, type of product being stored, how often new product is brought in and the length of time the door to the room remains open. Summer conditions of high humidity can cause heavier frost loads. It may be necessary to change the number of defrost cycles seasonally.
4. At least every six months check all fan motors. Tighten motor mounting screws and fan set screws.

8 TROUBLESHOOTING CHART

PROBLEM	POSSIBLE CAUSES	CORRECTIVE ACTION
Excessive buildup of frost on coil	<ul style="list-style-type: none"> - Defrost time is too short - Very high humidity in room - Heater capacity is too small 	<ul style="list-style-type: none"> - Extend defrost time on timer - Limit access to cooler and do not keep doors open during stocking - Change to bigger capacity or add more heater
Accumulation of ice or water in drain pan	<ul style="list-style-type: none"> - Drain line clogged - Drain pipe does not have slope angle - Indoor unit not aligned or installed at level in all directions - Drain line does not have drain trap 	<ul style="list-style-type: none"> - Clean drain line. Make sure drain line is insulated properly - Install the drain line with slope - Check unit installation and align the unit level at all directions - Install drain line trap
Noise	<ul style="list-style-type: none"> - Resonance on the vibrating mounting parts - Vibration of fan or fan mounting due to misalignment 	<ul style="list-style-type: none"> - Fix the position of part correctly to prevent vibrations - Fix the position of fan correctly or replace if defective
Room temperature not coming down	<ul style="list-style-type: none"> - Room thermostat defect - Insufficient or no refrigerant supply to evaporator - Frost build up on evaporator coil - Defrosting too frequent - Wrong combination of unit: <ul style="list-style-type: none"> • Unit cooler is too big against to outdoor unit • Unit cooler is too small against to cooling load 	<ul style="list-style-type: none"> - Check thermostat setting and replace if required and check sensor location - Investigate cause (leakage, choking, etc.), repair fault and charge system if necessary - Defrost the coil and clean the frost - Reduce defrost cycle frequency - Review and reselect the unit combination

9 E-Waste Guideline



DAIKIN AIRCONDITIONING INDIA PVT. LTD.

210, 1st FLOOR, OKHLA INDUSTRIAL AREA, PHASE 3, DELHI-110020

PROTECT THE ENVIRONMENT FROM E-WASTE (GUIDELINES)

Meaning of E-waste under E-Waste (Management) Rules,2022 (E-waste Rules)

-Waste electrical and electronic equipment, whole or in part of reject from their manufacturing and repair process, which are intended to be discarded.

Our product is RoHS compliant.



Don't dump Electrical and Electronic Products in Garbage Bins

DO'S & DONT'S

DO'S	
Run and maintain the air conditioner as per the instructions given in the operation / instruction manual	✓
Ensure that an authorised person repairs your air conditioner	✓
Call our local authorised dealer or our toll free number to dispose your air conditioner	✓
Contact an authorised dealer in case of installation or de-installation	✓
Consult our local authorised dealer or our toll free number on the life span of the air conditioner	✓

DONT'S	
Do not try to repair your air conditioner on your own	✗
Do not sell or dispose your air conditioner or parts to an unauthorised Kabbadi wala / Scrap Dealer / Ragpickers	✗
Do not dismantle your air conditioner on your own	✗
Do not get your air conditioner or any parts repaired by an unauthorised person	✗
Do not dispose off the E-waste in landfills	✗
Do not use the air conditioner as furniture after its use	✗

Customer Contact Center : 011-4031 9300/1860-180-3900
For further information visit us at www.daikinindia.com

3P323294-1G



**DAIKIN AIRCONDITIONING
INDIA PVT. LTD.**

12th Floor, Building No. 9, Tower A,
DLF Cyber City, DLF Phase - III
Gurgaon - 122002, Haryana (India)
Tel: +91-0124-4555444
Fax: +91-0124-4555333

3P647989-1-KA G