



# Split System Air Conditioner

INSTALLATION MANUAL <FOR OUTDOOR UNIT>  
READ THESE INSTRUCTIONS CAREFULLY BEFORE INSTALLATION.

NEW REFRIGERANT (R32) SERIES  
RZVFQ50,71AV16 / RZMFQ50,71AV16

- Note : Read the precautions in this manual carefully before operating the unit.  
 This appliance is filled with R32.

## CONTENTS

※ SAFETY PRECAUTIONS.....	1
1. BEFORE INSTALLATION.....	3
2. SELECTING INSTALLATION SITE.....	3
3. INSTALLATION SERVICE SPACE.....	4
4. PRECAUTIONS ON INSTALLATION.....	7
5. REFRIGERANT PIPING WORK.....	7
6. AIRTIGHTNESS TEST AND AIR-PURGE.....	10
7. CHARGING REFRIGERANT.....	11
8. ELECTRICAL WIRING WORK.....	12
9. CHECK ITEMS BEFORE TEST OPERATION AND FIELD SETTINGS.....	15
10. TEST OPERATION.....	16

## WARNING THERE IS A RISK OF EXPLOSION OR FIRE

- Do not mix air in the refrigerating cycle during pump down operation.
- Do not use oxygen for air tight test.
- Do not use refrigerant other than the specified one or flammable material ( e.g. propane ) in the refrigerant cycle. They may cause over pressure in the refrigerating cycle and result in explosion, fire or injury. Our company assumes no responsibility for failure or malfunction caused by filling or mixing of anything other than the specified refrigerant.

## CAUTION ABOUT ISOLATING RESISTANCE OF COMPRESSOR

If refrigerant accumulates in the compressor after completing installation, the insulation resistance can drop, but if it at least 1 MΩ, then the unit will not break down.

- Connect the power supply to the unit and after 6 hours check if the insulation resistance of the compressor rises. (Energize and heat the compressor to vaporize the refrigerant accumulated in the compressor.)
- If the earth leakage breaker actuates, check if the earth leakage breaker is equipped with a device to cope with high harmonics. To prevent wrong actuation of the earth leakage breaker due to the inverter, make sure to adopt an earth leakage breaker equipped with a device to cope with high harmonics.

- Please make sure to confirm that R32 (new refrigerant) is used in installation work in advance. (It may not operate normally, if refrigerant type is different.)
- The refrigerant R32 requires that strict precautions be observed for keeping the system clean, dry and tightly sealed.
  - Clean and dry  
Strict measures must be taken to keep impurities (Including SUNISO oil and other mineral oils as well as moisture) out of the system.
  - Tightly sealed  
R32 contains no chlorine, does not destroy the ozone layer and so does not reduce the earth's protection against harmful ultraviolet radiation. R32 will contribute only slightly to the greenhouse effect if released into the atmosphere. Therefore, sealing tightness is particularly important in installation. Carefully read the chapter **5 REFRIGERANT PIPING WORK** and strictly observe the correct procedures.

- The design pressure of this unit : High/Low pressure area are shown in the right table. The refrigerant piping is a high pressure area, Use the refrigerant piping which supports the design pressure. The piping specifications, please refer to chapter **5 REFRIGERANT PIPING WORK**



Outdoor Unit	Design pressure	Cooling
RZVFQ50 • 71AV16	High	4.17
RZMFQ50 • 71AV16	Low	2.21

- Be sure to connect the indoor unit, which is dedicated to R32. See the catalog for indoor unit models which can be connected. (Normal operation is not possible when connected to other units.)

(Units: MPa)

## READ THESE INSTRUCTIONS CAREFULLY BEFORE INSTALLATION

- This manual classifies the precautions into WARNINGS and CAUTIONS. Be sure to follow all the precautions below. They are all important for ensuring safety.

 <b>WARNING</b>	Indicates a potentially hazardous situation which, if not avoided, could result in death or serious injury.
 <b>CAUTION</b>	Indicates a potentially hazardous situation which, if not avoided, may result in minor or moderate injury. It may also be used to alert against unsafe practices.

- After the installation is completed, test the air conditioner and check if the air conditioner operates properly. Give the user adequate instructions concerning the use and cleaning of the indoor unit according to the operation manual. In particular, make sure to explain with regard to "SAFETY PRECAUTIONS" and "Not malfunction of the air conditioner". Ask the user to keep this manual and the operation manual together in a handy place for future reference.
- This air conditioner comes under the term "appliances not accessible to the general public".

### **WARNING**

- Ask your local dealer or qualified personnel to carry out installation work. Improper installation may result in water leakage, electric shocks or a fire.
- Perform installation work in accordance with this installation manual. Improper installation may result in water leakage, electric shocks or a fire.
- Consult your local dealer regarding what to do in case of refrigerant leakage. When the indoor unit is installed in a small room, it is necessary to take proper measures so that the amount of any leaked refrigerant does not exceed the concentration limit in the event of a leakage. Otherwise, this may lead to an accident due to oxygen deficiency.
- Be sure to use only the specified parts and accessories for installation work. Failure to use the specified parts may result in the air conditioner fall down, water leakage, electric shocks, a fire, etc.
- Install the air conditioner on a foundation that can withstand its mass. Insufficient strength may result in the air conditioner fall down and causing injury.
- Carry out the specified installation work in consideration of strong winds, typhoons, or earthquakes. Improper installation may result in an accident such as the air conditioner falling.
- Make certain that all electric work is carried out by qualified personnel according to the applicable legislation (note 1) and this installation manual, using a separate circuit. In addition, even if the wiring is short, make sure to use a wiring that has sufficient length and never connect additional wiring to make the length sufficient. Insufficient capacity of the power supply circuit or improper electric construction may lead to electric shocks or a fire. (note 1) Applicable legislation means "All international, national and local directives, laws, regulations and/or codes which are relevant and applicable for a certain product or domain."
- Earth the air conditioner. Do not connect the earth wiring to gas or water piping, lightning conductor or telephone earth wiring. Incomplete earthing may cause electric shocks or a fire. 
- Be sure to install an earth leakage circuit breaker. Failure to do so may cause electric shocks or a fire.
- The appliance must be stored in a room without continuously operating ignition sources (for example : open flames, an operating gas appliance or an operating electric heater).
- Do not pierce or burn.
- Be aware that refrigerant may not contain an odour.
- Comply with national gas regulations.
- Be sure to switch off the unit before touching any electrical parts. Touching a live part may result in electric shocks.
- Make sure that all wiring is secure, using the specified wiring and ensuring that external forces do not act on the terminal connections or wiring. Incomplete connection or fixing may cause overheating terminals or fire.
- When wiring between the outdoor and indoor units, and wiring the power supply, from the wiring orderly so that the structural parts such as a cover can be securely fastened. If the cover is not in place, electric shocks or a fire may be caused.
- Do not add wiring. It may result in heat generation. Electric shocks or fire.
- When installing or relocating the air conditioner, be sure to bleed the refrigerant circuit to ensure it is free of air, and use only the specified refrigerant (R32). The presence of air or other foreign matter in the refrigerant circuit causes abnormal pressure rise, which may result in equipment damage and even injury.
- If refrigerant gas leaks during installation work, ventilate the area immediately. Toxic gas may be produced if refrigerant gas comes into contact with a fire.
- After completing the installation work, check to make sure that there is no leakage of refrigerant gas. Toxic gas may be produced if refrigerant gas leaks into the room and comes into contact with a source of a fire, such as a fan heater, stove or cooker.
- Never directly touch any accidental leaking refrigerant. This could result in severe wounds caused by frostbite.
- Do not stand on the outdoor unit or put things on it. The unit may fall down or drop, and cause accidents.
- Do not charge any refrigerant into the refrigeration cycle other than the designated refrigerant. It may cause an explosion or a fire due to leakage or a burst due to abnormally high pressure in the refrigeration cycle.
- Do not extend wiring on the way. It may cause heat generation, electric shocks or fire.
- At the installation work, install the refrigerant piping firmly before operating the compressor. If the compressor is operated without installing firmly and the service valve is in open condition, it sucks the air, etc., and the pressure inside the refrigerant circle becomes abnormally high. It may cause injury and breakage.
- At pump down work, stop the compressor before removing the refrigerant piping. If removing the refrigerant piping when the compressor is operated with its service valve in open condition, it sucks the air, etc., and the pressure inside the refrigerant circle become abnormally high, which may cause injury and breakage.
- The appliance ( RZV/MF50~71BRV16 ) shall be installed operated and stored in a room with floor area larger than 2.76 m<sup>2</sup> (wall 71) and 1.84 m<sup>2</sup> (others model).
- When flared joints are reused indoors, the flare part shall be re-fabricated.

## ⚠ CAUTION

- Install drain piping according to this installation manual to ensure good drainage, and insulate the piping to prevent condensation. Improper drain piping may cause water leakage, make the furniture get wet.
- Install the indoor and outdoor units, power cord and connecting wires at least 1 meter away from televisions or radio to prevent picture interference and noise. (Depending on the incoming signal strength, a distance of 1 meter may not be sufficient to eliminate noise.)
- Install the indoor unit as far as possible from fluorescent lamps. If a wireless remote controller kit is installed, the transmission distance of the remote controller may be shorter in a room where an electronic lighting type (inverter or rapid start type) fluorescent lamp is installed.
- In a domestic environment this product may cause radio interference in which case the user may be required to take adequate measures.
- Make sure to provide for adequate measures in order to prevent that the outdoor unit be used as a shelter by small animals. Small animals making contact with electrical parts can cause malfunctions, smoke or fire. Please instruct the customer to keep the area around the unit clean.
- Disposal requirements  
Dismantling of the unit, treatment of the refrigerant, of oil and of other parts must be done in accordance with relevant local and national legislation.
- Only qualified personnel can handel, fill, purge and dispose of the refrigerant.
- Do not install the air conditioner in places such as following:
  1. Where there is mist of oil, oil spray or vapor for example a kitchen.  
Resin parts may deteriorate, and cause them to fall out or water to leak.
  2. Where corrosive gas, such as sulfurous acid gas, is produced.  
Corrosion of copper pipings or brazed parts may cause the refrigerant to leak.
  3. Where there is machinery which emits electromagnetic waves.  
Electromagnetic waves may disturb the control system, and cause malfunction of the equipment.
  4. Where flammable gases may leak, where carbon fiber or ignitable dust is suspended in the air or where volatile flammables, such as thinner or gasoline, are handled. If the gas should leak and remain around the air conditioner, it may cause ignition.
  5. The place that the vibration or the voltage fluctuation give influence. Vehicles, vessels, etc.  
The vibration may cause a damage and the voltage fluctuation may cause an abnormal operation.
  6. Where small animals may build a nest, fallen leaves are accumulated, or weeds are overgrown.  
If small animals touch the electrical parts inside, this may cause malfunction, smokes or a fire.

■ Important information regarding the refrigerant used  
This product contains fluorinated greenhouse gases covered by the Kyoto Protocol. Do not vent gases into the atmosphere.  
Refrigerant type: R32  
GWP<sup>(1)</sup> value: 675  
<sup>(1)</sup>GWP = global warming potential  
• The refrigerant quantity is indicated on the unit name plate.

## 1 BEFORE INSTALLATION

<DO NOT THROW AWAY ACCESSORIES FOR INSTALLATION>

### ⚠ CAUTION

- Read these instructions carefully before installation. For installation of the indoor unit, refer to the indoor unit installation manual.

RZVFQ50,71AV16  
RZMFQ50,71AV16

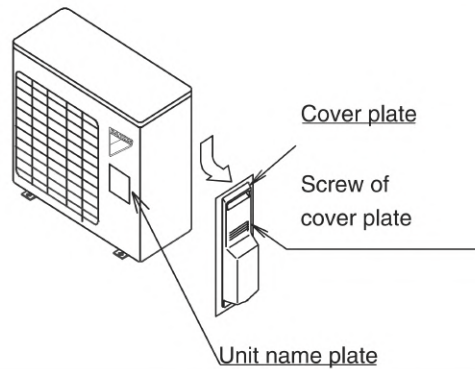

### HANDLING

As shown in the figure, bring the unit slowly by grabbing the left and right grips. (Take care not to let hands or objects come in contact with rear fins.)

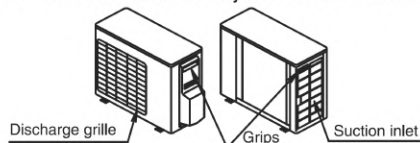

Place your hands on the corner instead of holding the suction inlet in the side of the casing, otherwise the casing could be deformed.

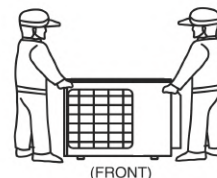

(FRONT)

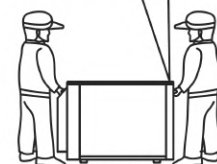

(BACK)

### INSTALLATION CONSTRUCTION ACCESSORIES

Be sure only to use accessories made by DAIKIN which are specifically designed for use with the equipment.

### CAUTION

Work in a team of at least two people when carrying the outdoor unit

## 2 SELECTING INSTALLATION SITE (1/2)

(1) Select the installation location that meets the following conditions and get approval of the customer.

- Places where is no risk of flammable gas leakage.
- Places where the outdoor unit does not bother next-door neighbors.
- Safe places where can withstand the unit's mass and vibration and where the air conditioner can be installed level.
- Places where are well-ventilated and where servicing space can be well ensured.  
The minimum required space is shown in chapter ④ INSTALLATION SERVICE SPACE
- Where the piping length between the indoor and the outdoor units is ensured within the allowable piping length. (Please see chapter ⑤ REFRIGERANT PIPING WORK)
- Do not allow wind from the same direction to blow frequently toward the outlet or inlet of the outdoor unit. If the wind is likely to blow as mentioned above, make sure to keep a sufficient service space and install a wind protective shield.

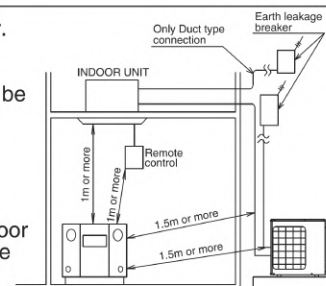

### ⚠ CAUTION

Inverter air conditioners may cause noise to occur in electrical appliances. As shown in the right drawing, select an installation site well away from radios, PCs, and stereos. Especially in the areas where the incoming signal strength is weak, keep the indoor remote controller 3 meter or more from electrical appliances. Put the power supply and transmission wiring in a metal piping and ground the metal piping.

## 2 SELECTING INSTALLATION SITE (2/2)

### ⚠ CAUTION

- 1) In a domestic environment this product may cause radio interference in which case the user may be required to take adequate measures.
- 2) When installing the unit in a place exposed to strong wind, pay special attention to the following. Strong winds of 5 m/sec or more blowing against the outdoor unit's air outlet causes short circuit (suction of discharge air) and this may have the following consequences:
  - Deterioration of the operational capacity.
  - Disruption of operation due to rise of high pressure.
  - When a strong wind blows continuously on the face of the unit, the fan can start rotating very fast until it breaks.
 Refer to the figures for installation of this unit in a place where the wind direction can be foreseen.
- 3) Following the installation place, it is expected that the influence of the strong wind is great.
  - The flat area which receives the adverse wind such as typhoon directly since there is no obstacles such as buildings and mountains. (Including coast line, shoreline of lake and mountain region.)
  - The installation place that no obstacles around the outdoor unit to prevent the adverse wind, for example, walls and buildings that are higher than the applicable outdoor unit, etc. Please take measures when installing especially on a rooftop.
  - Since the outdoor unit may fall down, attach the fixture for preventing overturning(option).

Turn the air discharge toward the building's wall fence or screen.

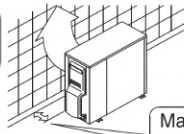

Make sure there is enough room to do the installation

STRONG WIND

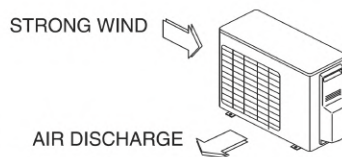

Set the outlet side at right angle to the direction of the wind.

AIR DISCHARGE

STRONG WIND

- 4) Prepare a water drainage channel around the foundation, to drain waste water from around the unit.
- 5) If the water drainage of the unit is not easy, please build up the unit on a foundation of concrete blocks, etc. (the height of the foundation should be maximum 150 mm).
- 6) If you install the unit on a frame, please install a waterproof plate within 150 mm of the underside of the unit in order to prevent the invasion of water from the lower direction.

## 3 INSTALLATION SERVICE SPACE (1/3)

- The installation servicing spaces shown in these drawings are based on the outdoor unit inlet area temperature of 35°C(DB) for COOLING operation. If the planned inlet area temperature exceeds 35°C(DB), or if the heat load of all outdoor units is increased significantly and exceeds the maximum operating capacity, secure a larger space than that indicated by the inlet dimensions in these drawings.
- For installation, consider both pedestrian and air flow paths and choose a suitable pattern from these drawings to match the space available field. (If the number of units to be installed exceeds the patterns in these drawings, consider there is nothing short-circuits.)
- Regarding the front space, position the units with consideration to the space required for the refrigerant piping work. (Consult your dealer if the work conditions do not match those in the drawings.)
- Secure appropriate space when using a side piping outlet.

### STAND-ALONE INSTALLATION

#### No Obstacle above

- 1) Obstacle on the suction side only

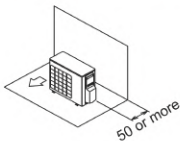

- To secure service space, more than 250 mm of each products at right side in needed.

(Units: mm)

- 2) Obstacle on both sides and suction side, too

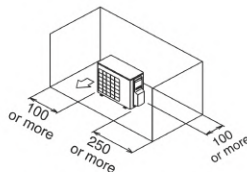

- 3) Obstacle on the discharge side only

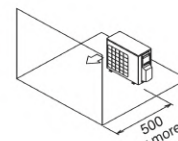

#### Obstacle above, too

- 1) Obstacle on the suction side, too

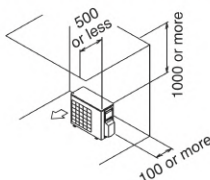

- 2) Obstacle on both sides and suction side, too

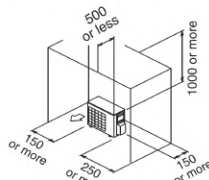

- 3) Obstacle on the discharge side only, too

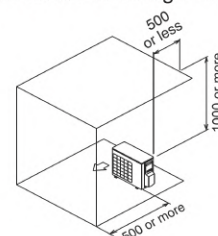

### 3 INSTALLATION SERVICE SPACE (2/3)

When there are obstacles on both suction and discharge sides

- To secure service space, (Units: mm) more than 250 mm of each products at right side in needed.

**Pattern 1** When the obstacles on the discharge side is higher than the unit

- 1) No obstacle above (There is no limit for the height of obstructions on the suction side.)
- 2) Obstacle above, too The relations between H, A and L are as follows.

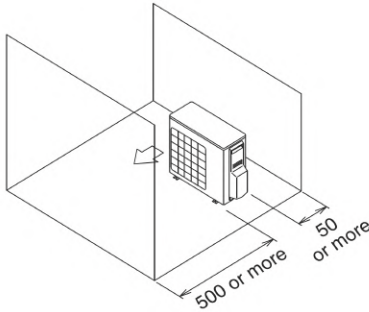

	L	A
$L \leq H$	$L \leq 0.5H$	750 or more
	$0.5H < L \leq H$	1000 or more
$L > H$	Set the stand as: $L \leq H$	

- ※ - Close the bottom of the stand to prevent the discharged air from being bypassed.
- The limitation of facilities connection is until 2 unit only.
- In case of more than dimension in ( ), It is no need to establish the stand although  $L > H$

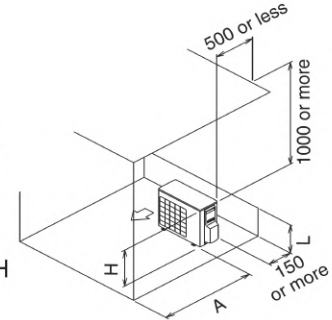

**Pattern 2** When the obstacle on the discharge side is lower than the unit

- 1) No obstacle above (There is no limit for the height of obstructions on the suction side.)
- 2) Obstacle above, too The relations between H, A and L are as follows.

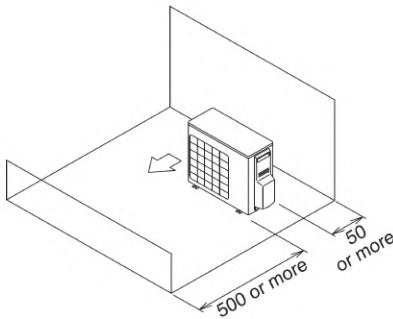

	L	A
$L \leq H$	$L \leq 0.5H$	50 or more
	$0.5H < L \leq H$	100 or more
$L > H$	Set the stand as: $L \leq H$	

- ※ - Close the bottom of the stand to prevent the discharged air from being bypassed.
- The limitation of facilities connection is until 2 unit only.
- In case of more than dimension in ( ), It is no need to establish the stand although  $L > H$

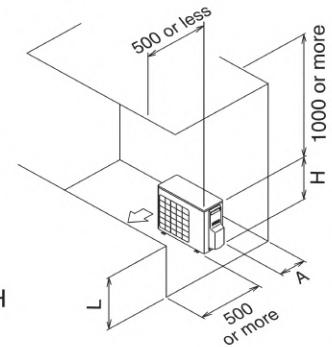

#### SERIES INSTALLATION ( 2 OR MORE )

- ※ Inside extraction, please provide the space of piping. (Units: mm)
- To secure service space, more than 250 mm of each products at right side in needed.

No obstacle above

- 1) Obstacle on the suction side and both sides

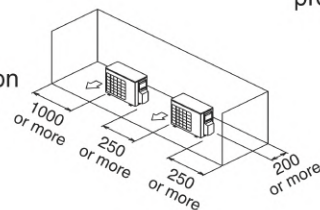

- 2) Obstacle on the discharge side only

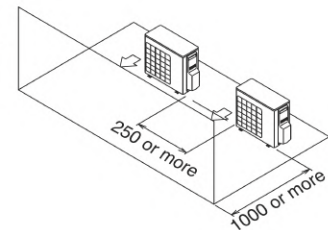

Obstacle above, too

- 1) Obstacle on the discharge side

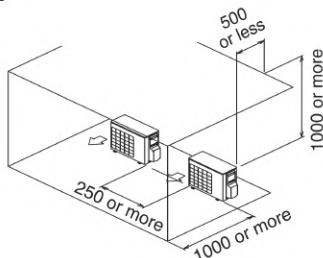

- 2) Obstacle on the suction side and both sides

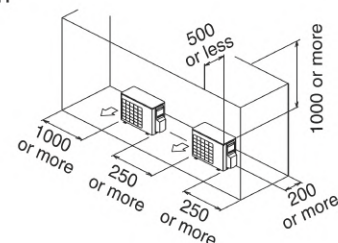

### 3 INSTALLATION SERVICE SPACE (3/3)

#### When there are obstacles on both suction and discharge sides

- To secure service space, more than 250 mm of each products at right side in needed.

**Pattern 1** When the obstacles on the discharge side is higher than the side unit

1) No obstacle above (There is no limit for the height of obstructions on the suction side.)

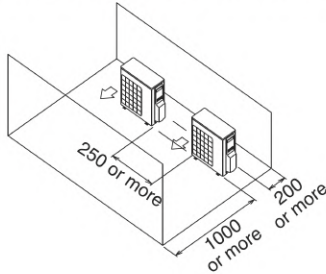

2) Obstacle above, too

The relations between H, A and L are as follows.

	L	A
$L \leq H$	$L \leq 0.5H$	1000 or more
	$0.5H < L \leq H$	1250 or more
$L > H$	Set the stand as: $L \leq H$	

- ※ - Close the bottom of the stand to prevent the discharged air from being bypassed.
- The limitation of facilities connection is until 2 unit only.
- In case of more than dimension in ( ), It is no need to establish the stand although  $L > H$

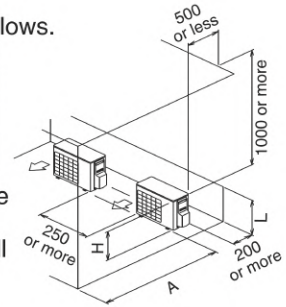

**Pattern 2** When the obstacle on the discharge side is lower than the unit

1) No obstacle above (There is no limit for the height of obstructions on the suction side.)

The relations between H, A and L are as follows.

L	A
$L \leq 0.5H$	150 or more
$0.5H < L \leq H$	200 or more

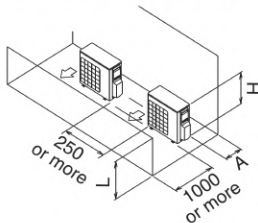

2) Obstacle above, too

The relations between H, A and L are as follows.

	L	A
$L \leq H$	$L \leq 0.5H$	150 or more
	$0.5H < L \leq H$	200 or more
$L > H$	Set the stand as: $L \leq H$	

- Close the bottom of the stand to prevent the discharged air from being bypassed.
- The limitation of facilities connection is until 2 unit only.
- In case of more than dimension in ( ), It is no need to establish the stand although  $L > H$

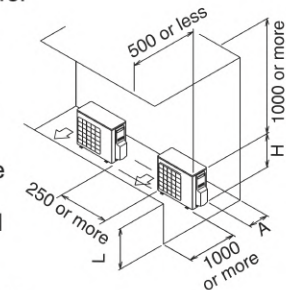

(Units: mm)

#### DOUBLE-DECKER INSTALLATION

- Do not stack more than two unit.
- The drain piping construction size of upper side outdoor unit is needed about 100 mm.
- In side extraction, please provide the space of piping.

1) Obstacle on the discharge side

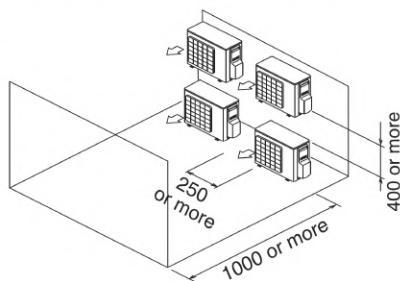

2) Obstacle on the suction side

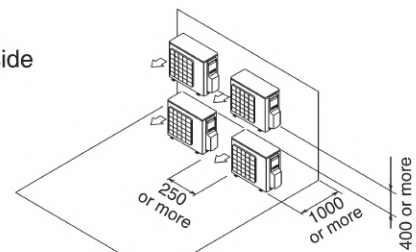

(Units: mm)

#### MULTIPLE ROWS OF SERIES INSTALLATION (ON THE ROOFTOP, ETC.)

1) One row of stand-alone installation

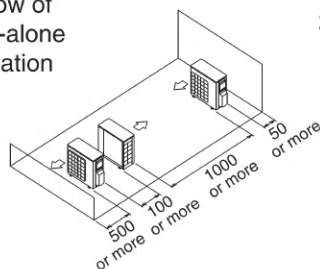

2) Rows of series installation (2 or more)

The relations between H, A and L are as follows.

	L	A
$L \leq H$	$L \leq 0.5H$	150 or more
	$0.5H < L \leq H$	200 or more
$L > H$	Can not be installed	

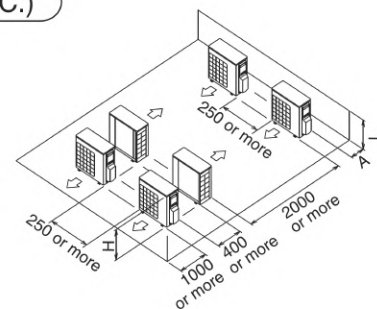

## 4 PRECAUTIONS ON INSTALLATION

- Check the strength and level of the installation ground so that the unit will not cause any operating vibration or noise after installed.
- In accordance with the foundation drawing in Fig. 1, fix the unit securely by means of the foundation bolts. (Prepare 4 sets of M12 foundation bolts, nuts and washers each which are available on the market.)
- It is best to screw in the foundation bolts until their length are 20 mm from the foundation surface.
- Fix the outdoor unit to the foundation bolts using nuts with resin washers. (See the left-hand of Fig. 1 drawing)  
If the coating on the fastening area is stripped off, the nuts rust easily.

### <Drain pipe disposal>

- If drain pipe disposal from the outdoor unit causes trouble, (for example, if the drain water may splash on people) provide the drain piping by using of the drain plug (optional).
- Then, coat the area around the bored holes with rust preventive coating to cover the metal exposure.
- Make sure the drain works properly.

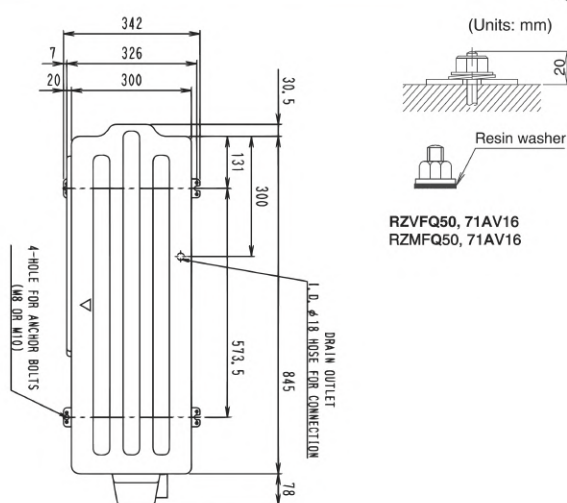

Fig : 1 BOTTOM VIEW

## 5 REFRIGERANT PIPING WORK (1/4)

### ⚠ CAUTION

#### To plumbing person

- Important information regarding the refrigerant used. This product contains fluorinated greenhouse gases covered by the Kyoto Protocol. Do not vent gases into the atmosphere.  
GWP (global warming potential) of R32 refrigerant type = 675
- Use R32 as additional for charging.
- Do not use flux when brazing refrigerant piping.  
Use phosphor copper brazing filler metal (BCuP-2:JIS Z 3264/B-Cu93P-710/795:ISO 3677) that does not require flux.  
(If chlorinated flux is used, the piping will be corroded and, in addition if fluorine is contained, the refrigerant oil will be deteriorated and the refrigerant circuit will be affected badly.)
- After chapter 7 CHARGING REFRIGERANT is completed, be sure to open the stop valves before performing 9 LOCAL SETUP.  
(Operating the unit with the valve shut will break the compressor.)

#### 《Precaution when reuse existed refrigerant pipe》

Please keep below points in order to reuse existed pipe, failure may caused if have a fault.

- Below are pipes shall always make new construction, do not reuse piping.
  - When removed from indoor unit or outdoor unit for a long time.  
(Moisture entry to internal pipe, wastes entry can be occurred.)
  - When copper tube is corroded.
  - When pipe thickness is insufficient (refer to 5-4 REFRIGERANT PIPE SIZE AND ALLOWABLE PIPE LENGTH table).
  - Do not reuse flare for refrigerant leak protection, please make flare processing.
  - Do not reuse flare nut, please use flare nut in product accessories.
  - Make sure to do refrigerant leak check in case there is brazing area while perform field piping.
  - If insulation is deteriorate, make sure to exchange to new one.

#### 5-1 INSTALLATION TOOLS

Be sure to use the dedicated tools to ensure sufficient pressure resistance and prevent the entry of any impurities.

Manifold gauge Charging hose	To ensure sufficient pressure resistance and prevent the entry of any impurities (mineral oils such as Suniso oil and liquids), use the R410A or R32 dedicated item (the screw specifications for R410A or R32 differ).
Vacuum pump	Be extremely careful not to flow the pump oil backward to inside the piping when the pump is stopped. Use a pump which enables vacuuming to -0.1 MPa(-755mmHg) of the gauge pressure.

#### 5-2 SELECTION OF PIPING MATERIAL

- Use the piping whose inside and outside are clean and with no harmful substances for use such as sulphur, oxide, dust, dust from cutting, grease, or liquid (contamination) is attached.
- For the refrigerant piping, use the following material.  
Material: Deoxidised phosphorous seamless copper piping  
Temper grade: Use piping with temper grade in function of piping diameter as listed in the table on section 5-4 REFRIGERANT PIPE SIZE AND ALLOWABLE PIPE LENGTH  
Size: Decide based on section 5-4 REFRIGERANT PIPE SIZE AND ALLOWABLE PIPE LENGTH  
Thickness: Comply with applicable legislation. The minimal piping thickness for R32 piping must be in accordance with the table on section 5-4 REFRIGERANT PIPE SIZE AND ALLOWABLE PIPE LENGTH
- Be sure to perform piping work using measurements within the maximum allowable length and height difference described on section 5-4 REFRIGERANT PIPE SIZE AND ALLOWABLE PIPE LENGTH

## 5 REFRIGERANT PIPING WORK (2/4)

<Please refer to installation manual of indoor unit about indoor unit's refrigerant piping>

### 5-3 CARE OF PIPE

- Prevent contamination or moisture from getting into the piping.
- Pay special attention when running the copper piping through the through-hole or when leading the edge of the piping outside the room.
- Refrigerant piping must be protected from physical damage. Install a plastic cover or equivalent.

PLACE	INSTALLATION PERIOD	PROTECTION METHOD	PLACE	INSTALLATION PERIOD	PROTECTION METHOD
OUTDOOR	More than a month	Pinch the pipe	INDOOR	Unquestioned	Pinch or tape pipe
	Less than a month	Pinch or tape pipe			

### 5-4 REFRIGERANT PIPE SIZE AND ALLOWABLE PIPE LENGTH

- One way maximum allowable piping length means the maximum length of liquid side piping or gas side piping.
- Equivalent length is the pressure loss due to L joints, traps, and so on along the refrigerant piping converted to a straight piping length of the same size and added to the overall value.  
Please see the Engineering Data for calculation of equivalent length.
- Please give the vertical interval between the indoor and outdoor as 20m or less.

#### CAUTION

- This unit is chargeless specification. Due to chargeless length and allowable piping length will be different depend on field pipe size.

#### Piping bend radius

(Units : mm)

Piping diameter	Pipe thickness (material)	Bend radius
Ø 6.35mm	0.8 mm (C1220T-O, Type O)	30mm or more
Ø 12.7mm	0.8 mm (C1220T-O, Type O)	40mm or more
Ø 15.8mm	1.0 mm (C1220T-O, Type O)	50mm or more

#### Refrigerant pipe size and chargeless length

Outdoor unit type	Liquid pipe size (type)	Chargeless length
RZVFQ50 / 71AV16 RZMFQ50 / 71AV16	Ø 6.35mm x t 0.8 mm (type O)	10m

### WARNING

- When flared joints are reused indoors, the flared part shall be re-fabricated.

### CAUTION

- Use dedicated piping cutters and flaring tools for R410A or R32.
- When making a flare connection, apply ether or ester oil only to the flare inner surface.
- Use only the flare nuts attached to the unit. If other flare nuts are used, it may cause refrigerant leakage.
- To prevent contamination, dust or moisture from getting into the piping, take measures such as pinching or taping the piping.

### 5-5 CONSTRUCTION OF REFRIGERANT PIPING

- Field pipes can be installed in Back - side connection. <Fig.2>
- Do not allow any substances other than the specified refrigerant such as air to mix into the refrigerant circuit.

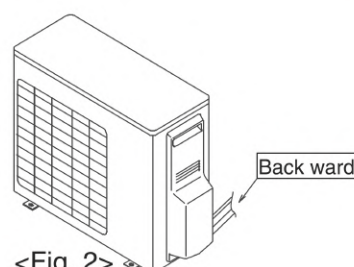

<Fig. 2>



## 5 REFRIGERANT PIPING WORK (3/4)

<Please refer to installation manual of indoor unit about indoor unit's refrigerant piping>

### PREVENTING FOREIGN OBJECTS FROM ENTERING

- Plug the pipe through-holes with putty or insulating material (field supply) to cover all gaps, as shown in the figure.
- Insects or small animals entering the outdoor unit may cause a short circuit in the electrical box.

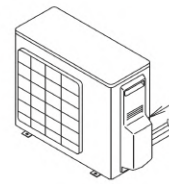

Putty or insulation material (Field supply)  
Refrigerant piping must be protected from physical damage. Install a plastic cover or equivalent.

### CAUTIONS FOR HANDLING STOP VALVE

**DO NOT OPEN THE STOP VALVE UNTIL 7 CHARGING REFRIGERANT FINISHED.**

- The stop valves for indoor-outdoor connecting piping are closed at shipment from the factory. The names of parts are shown in figure on the right.
- Since the side boards may be deformed if only a torque wrench is used when loosening or tightening flare nuts, always lock the stop valve with a wrenches and then use a torque wrench.

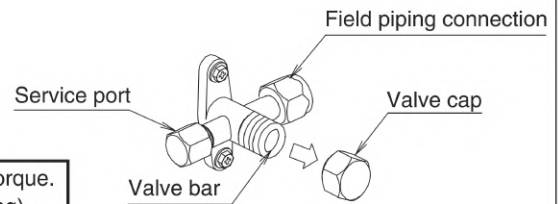

When tightening the flare of the stop valves, make sure to tighten by the rated torque. The rated torque is shown on (CAUTION FOR FLARE CONNECTION) (Following)

DO NOT APPLY FORCE ON THE VALVE CAP, THIS MAY RESULT IN A REFRIGERANT LEAK.

- For cooling operation under low ambient temperature or any other operation under low pressure, apply silicon pad or similar to prevent freezing of the gas stop valve flare nut (see figure).  
Freezing of the flare nut may cause refrigerant leak.

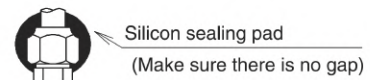

Silicon sealing pad  
(Make sure there is no gap)

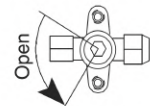

<Liquid side>

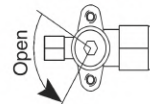

<Gas side>

### How to operate the stop valve

Use hexagonal wrenches 5mm.

- Opening the valve**
1. Place the hex wrench on the valve bar and turn counter-clockwise.
  2. Stop when the valve bar no longer turns. (It is now open.)

- Closing the valve**
1. Place the hex wrench on the valve bar and turn clockwise.
  2. Stop when the valve bar no longer turns. (It is now close.)

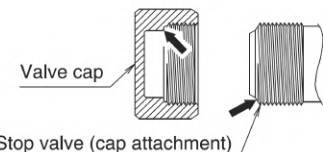

Stop valve (cap attachment)

### CAUTIONS FOR HANDLING VALVE CAP

- A seal is attached to the point indicated by the arrow. Take care not to damage it.
- Be sure to tighten the valve cap securely after operating the valves.

Liquid side		Gas side	
Valve size (mm)	Tightening torque(N•m)	Valve size (mm)	Tightening torque(N•m)
Ø6.35	15.7 ± 1.5	Ø12.7	54.9 ± 5.4
		Ø15.8	68.6 ± 6.8

### CAUTIONS FOR HANDLING SERVICE PORT

- Always use a flexible charge hose with a push-rod and valve to enable recovery of remaining refrigerant in the charge hose.
- After the work, tighten the valve cap in place.
- Tightening torque:  $12.7 \pm 1.2 \text{ N}\cdot\text{m}$

Do not use a charging hose of which pressing stick is slipped out from the center. (It may cause refrigerant leakage due to deformation to the valve stem of the service port)

### PRECAUTIONS FOR CONNECTING PIPING

- Take caution so that the refrigerant piping between the outdoor and indoor may not touch and sound proof cover and the plate as shown figure.
- If installing the outdoor unit higher than the indoor unit, caulk the space around insulation and tubes because condensation on the stop valves can seep through to the indoor unit side.

### PRECAUTIONS REGARDING INSULATION

Enhance the insulation of the refrigerant piping according to the installation conditions. If this is not done, condensation may form on the surface of the insulation. Please refer to the target values shown below.

- When the temperature and humidity conditions are 30°C and RH 75% or more:  
thickness of the insulation is 15 mm or more.
- When the temperature and humidity conditions are 30°C and RH 80% or more:  
thickness of the insulation is 20 mm or more.
- Be sure to insulate the liquid and gas sides interunit piping.  
It may become the cause of refrigerant leakage if it dose not insulate.  
(Be sure to use insulating material which can resistant.)

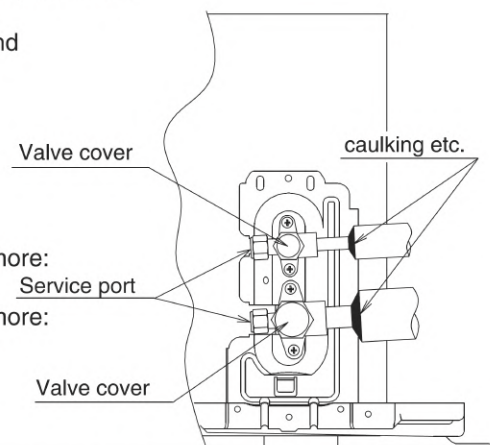

Caution

Insulation of interunit piping must be carried out up to the connection inside the casing. If the piping is exposed to the atmosphere, it may cause sweating or burn due to touching the piping, electric shocks or a fire due to the wiring touching the piping.

## 5 REFRIGERANT PIPING WORK (4/4)

### CAUTION FOR FLARE CONNECTION

- Please be sure to remove a flare nut with a two-dish spanner, and to bind after connection of piping using a spanner and a torque wrench.
- Refer to the following table for a flare part processing size.
- When connecting the flare nut, apply refrigerating machine oil to the flare (inside) and at first screw the nut 3 or 4 turns by hand. Coat here with ether or ester oil.
- Refer to the table for the dimensions for processing flares and for the tightening torques. (Too much tightening will end up in splitting of the flare.)
- After completing the installation, carry out a gas leak inspection of the piping connections with nitrogen and such.

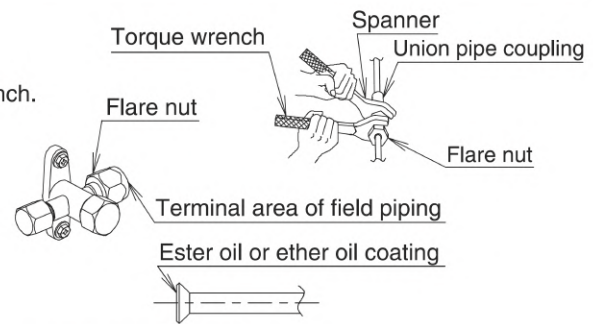

PIPING SIZE (mm)	TIGHTENING TORQUE	A DIMENSIONS FOR PROCESSING FLARES (mm)	FLARE SHAPE
Ø6.4	15.7 ± 1.5 N•m	8.9 ± 0.2	
Ø9.5	36.3 ± 3.6 N•m	13.0 ± 0.2	
Ø12.7	54.9 ± 5.4 N•m	16.4 ± 0.2	
Ø15.9	68.6 ± 6.8 N•m	19.5 ± 0.2	
Ø19.1	108.0 ± 10.8 N•m	23.8 ± 0.2	

- If a torque wrench is not available, be aware that the tightening torque may increase suddenly. Do not tighten nuts any further than to the angle as listed.
- When work is completed, be sure to check that there is no gas leakage.
  - ① A flare nut is bound tight with a spanner to the position whose torque with a bundle increases suddenly.
  - ② Only the angle of a right table is further bound tight from the position.

PIPING SIZE (mm)	FURTHER TIGHTENING ANGLE	RECOMMENDED ARM LENGTH OF TOOL
Ø6.4	60 to 90 degrees	About 150 mm
Ø9.5	60 to 90 degrees	About 200 mm
Ø12.7	30 to 60 degrees	About 250 mm
Ø15.9	30 to 60 degrees	About 300 mm
Ø19.1	20 to 35 degrees	About 450 mm

### PRECAUTIONS WHEN BRAZING THE REFRIGERANT PIPINGS

<Do not reuse joint which have been used once already>

- When brazing the refrigerant piping, carry out brazing work (NOTE 2) after substituting nitrogen for air (flow nitrogen into the piping and substitute nitrogen for air (NOTE 1) (see the drawing below)).

#### NOTES

1. The proper pressure for having nitrogen flow through the piping is approximately 0.02MPa, a pressure that makes one feel like breeze and can be obtained through a pressure reducing valve.
2. Do not use flux when brazing refrigerant piping. Use phosphor copper brazing filler metal (BCuP-2:JIS Z 3264/B-Cu93P-710/795:ISO 3677) that does not require flux. (If chlorinated flux is used, the piping will be corroded and, in addition if fluorine is contained, the refrigerant oil will be deteriorated and the refrigerant circuit will be affected badly.)

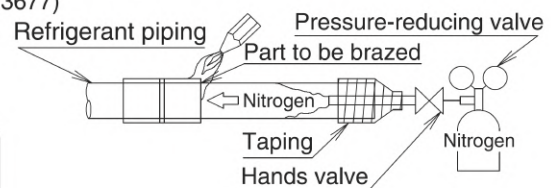

Prohibited

Do not use anti-oxidants when brazing the piping joints. (Residue can clog pipes and break equipment.)

## 6 AIRTIGHTNESS TEST AND AIR-PURGE

### AIRTIGHTNESS TEST

- Perform a refrigerant leakage check using nitrogen gas (airtightness test) with the outdoor unit stop valve close, to make sure there are no leakage.
- For the airtightness test, raise the pressure to the design pressure in the high pressure section (4.17 MPa) For the airtightness test, the unit passes the test if the pressure in the high pressure section does not drop for 24 hours after increasing to the design pressure. A correction is required since the pressure decreases approx. 0.01Mpa when the ambient temperature of 1°C decreases.
- If the pressure drop is confirmed, perform the airtightness test again after checking and modifying the leakage points.

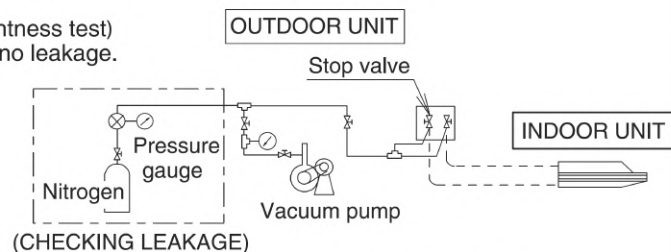

### AIR-PURGE

- Evacuate by the vacuum pump for more than 2 hours until the internal pressure decreases below -0.1MP. After that, leave it with -0.1MPa or less for more than one hour and confirm that the value of vacuum gauges does not increase.
- If the value of vacuum gauge increases, there is moisture inside the refrigerant piping or there are leakage points. Perform evacuation again after checking and improving the leakage points.

#### NOTE

- After doing an air-purge with a vacuum pump, the refrigerant pressure may not rise even if the stop valves are opened. This is because the refrigerant piping path is closed off by the outdoor unit electronic expansion valve, etc. There are no problems if the outdoor unit is run.

## 7 CHARGING REFRIGERANT (1/2)

Be sure to use R32 as refrigerant.

### ADDITIONAL REFRIGERANT CHARGING

This model is chargeless type, so it is not necessary to charge additionally if pipe does not exceed the maximum allowable length without additional charge.

Please refer to the following table about the maximum allowable length without additional charge.

Liquid piping size	Length for which additional charging is not required
ø6.35mm x t 0.8mm	10m

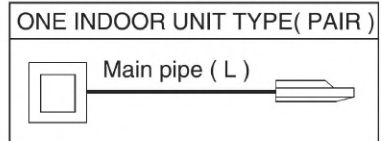

When piping length exceeds its of a top table,

or only when you perform recharging, Please be correctly charged according to the following.

For future servicing, please describe the amount of additional refrigerant charging, or the amount of recharging in the collective label in accessory set or back side of right side plate.

#### • In case of additional refrigerant charging

Please select the amount of additional refrigerant which suited piping length from the following table, and add it from the service port of liquid stop valve.

Outdoor units type	Liquid piping size	Length for which additional charging is not required	Length of piping exceeding the length for which additional charging is not required, R32 additional amount (kg)
			20m
RZV / MFQ50AV16 RZV / MFQ71AV16	ø6.35mm x t0.8mm	10m	20g/mtr

#### • Total refrigerant charging (When recharging due to exchange compressor, etc.)

Please charge refrigerant base on pipe length mentioned on the following table.

Outdoor units type	Liquid piping size	Piping length, R32 complete additional amount (kg)	
		5m-10 m	20m
RZVFQ50AV16	ø6.35mm	0.98	1.180
RZMFQ50AV16	ø6.35mm	0.85	1.050
RZV / MFQ71AV16	ø6.35mm	1.04	1.240

## 7 CHARGING REFRIGERANT (2/2)

**Precautions when adding R32** • Before charging, check whether the cylinder has a siphon attached or not.

Charging a cylinder with an attached siphon



Stand the cylinder upright at charging.  
(There is a siphon piping inside, so that cylinder need not be upside-down to charge with liquid.)

Charging other cylinders



Stand the cylinder upside-down and charge.  
(Turn the cylinder upside-down at charging.)

- To prevent entry of any impurities and insure sufficient pressure resistance, always use the special tools dedicated for R410A or R32.
- The refrigerant should be charged from the service port of the liquid side stop valve.

### WARNING

To persons incharge of piping work

- Please be sure to open a stop valve after a refrigerant charging end (if it operates shut, a compressor will break down).
- After complete charging of refrigerant carry out refrigerant leak check and heat insulation work.
- Please do not emit a refrigerant into the atmosphere indiscriminately.

## 8 ELECTRICAL WIRING WORK (1/3)

### WARNING

- Install the earth leakage circuit breaker. (A duty of installation of a earth leakage circuit breaker is imposed for an electric shock and fire accident prevention.  
The inverter is provided in the air conditioner. In order to prevent malfunction of the earth leakage breaker itself, use a breaker resistant to higher harmonics)
- Electrical wiring must be carried out by qualified personnel.
- Before obtaining access to terminal devices, all supply circuits must be interrupted.

### CAUTION

To the electricain

- Make sure to install a current balance type earth leakage breaker coping with high harmonics.  
(This unit is equipped with an inverter device. Use an earth leakage breaker coping with high harmonics to prevent wrong actuation.)
- Do not run the unit until the refrigerant charging is complete. (Operating the unit before the completion will break the compressor.)
- Do not remove the thermistors or sensors when the power supply and transmission wiring are connected.  
(Operating the unit with the thermistors and sensors removed will break the compressor.)
- Make certain that all electric wiring work is carried out by qualified personnel according to the applicable legislation and this installation manual, using a separate circuit. Insufficient capacity of the power supply circuit or improper electrical construction may lead to electric shocks or a fire.
- An insufficient power supply capacity or improper electric work may lead to electric shocks or a fire.
- The wiring between the indoor unit and outdoor unit must be for 230V.
- For electric wiring work, refer to also the " WIRING DIAGRAM ".
- When doing the electrical wiring, always shut off the power source before working, and do not turn on the branch switch until all work is complete.
- Make sure to earth the air conditioner. Earthing resistance should be according to applicable legislation.
- Do not connect the earth wiring to gas or water piping, lightning conductor or telephone earth wiring.
  - Gas piping.....Ignition or explosion may occur if the gas leaks.
  - Water piping.....Hard vinyl tubes are not effective earths.
  - Lightning conductor or telephone earth wiring.....Electric potential may rise abnormally if struck by a lightning bolt.
- The earth is needed in order to reduce the noise generated by the unit's inverter and influence on other appliances and to release the charged electric charge on the outdoor unit surface by leaked current.
- Do not install a phase advance capacitor for improvement of power factor. Since this unit is mounted with an inverter device, the effect of power factor improvement not only cannot be expected, but also there is a risk of the capacitor getting abnormally overheated due to harmonics.
- Be sure to use earth leakage breaker dedicated for earth leakage protection in combination with the load break switch with fuse or breaker for wiring.
- In case of three-phase. Machine, electric wiring must be connected in normal phase connection.
- For wiring, use the designated power supply wiring and connect firmly, then secure to prevent external force being exerted on the terminal attachment (power supply wiring, transmission wiring, earth wiring).
- Left-over wiring should not be wrapped and stuffed into the outdoor unit.
- To prevent the power wiring from being damaged by the knock hole edges, put it in a wiring piping or use insulated bush, etc. to protect it.
- To prevent the wiring from coming in contact with piping (particularly the high-pressure piping), secure it with the included clamping material as shown page 13.
- When wiring, form the wiring so that the front plate does not float and make sure the front plate is securely fastened.
- Fix the power supply wiring, the earth wiring and the transmission wiring by clamps as shown in the figure.

## 8 ELECTRICAL WIRING WORK (2/3)

- As shown in the following figure, please fix power supply wiring, field wiring and ground wire by clamp material.

RZVFQ50,71AV16  
RZMFQ50,71AV16

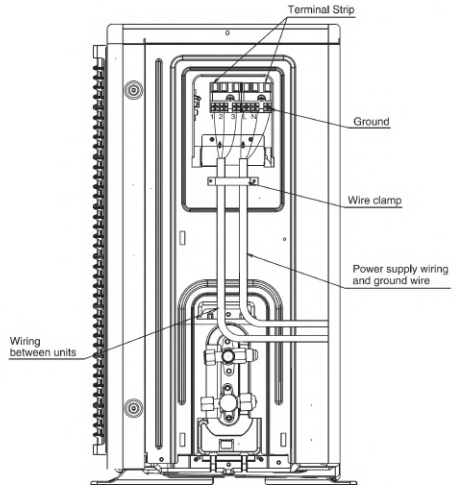

- Carry out insulated processing of attaching an insulated sleeve. Power supply wiring, wiring between units and ground wire with tying as clamp as shown below.

**⚠ Do not connect power supply to terminal block of transmission wiring. All system may get damaged.**

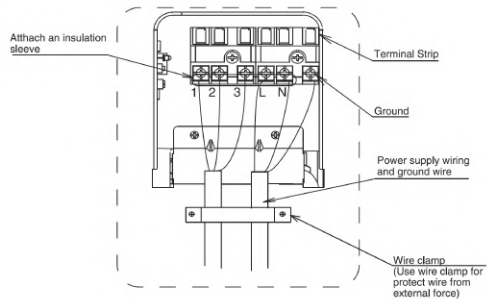

RZVFQ50,71AV16  
RZMFQ50,71AV16

### Connection of wiring

#### Precautions on wiring

- Use a round crimp-style terminal for connection to the power supply terminal board. In case it cannot be used due to unavoidable reasons, be sure to observe the following instruction.
- Do not connect wires of different gauge to the same power supply terminal. (Looseness in the connection may cause overheating.)

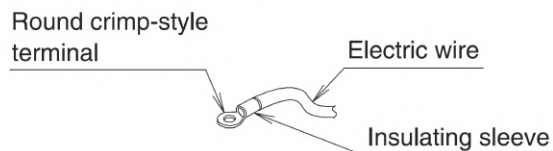

## 8 ELECTRICAL WIRING WORK (3/3)

When connecting wires of the same gauge, connect them according to the below figure.

Connect wires of the same gauge to both sides



Do not connect wires of different gauges



Do not connect wires of the same gauge to one side



- Never use the stranded wiring which is soldered. (Slack in the electric wiring may cause abnormal heat.)
- Use the required wirings, connect them securely and fix these wirings so that external force may not apply to the terminals.
- Use a proper screw driver for tightening the terminal screws. If an improper screw driver is used, it may damage the screw head and a proper tightening cannot be carried out.
- If a terminal is over tightened, it may be damaged. Refer to the table shown below for tightening torque of terminals.

Tightening torque (N•m)	
M4 (Wire between units terminal board)	1.50±0.30
M4 (Power supply terminal board)	1.50±0.30
M4 (Ground wire between units)	1.69±0.25
M5 (Ground wire between units)	3.55±0.50

### Precautions on connecting terminal of grounding

- Ground wiring should be taken out from the cut out section of a cup washer. (Otherwise, contact of ground wiring is inadequate and it is ineffective.)

Ring type crimp-style terminal

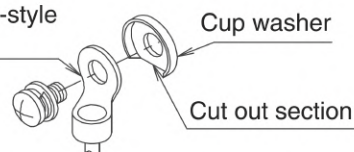

### WIRING OF POWER SUPPLY AND THE UNITS

For details on the wiring of the indoor unit and wiring between units refer to the installation manual of the indoor unit.

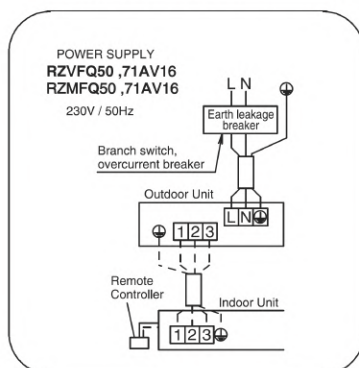

### • SPECIFICATIONS OF STANDARD WIRING COMPONENTS

Outdoor Unit	Power supply			Wire type of wiring between the units
	Recommended field fuse	Wire type (*)	Size	
RZVFQ50 / 71AV16 RZMFQ50 / 71AV16	16	H05VV-U3G	Wiring size and length must comply with local codes or [IEC 60335-1 (Table 11)]	H05VV-U4G2.5

(\*) Only in protected piping, use H07RN-F when protected pipes are not used.

(Supply cords shall not be lighter than polychloroprene sheathed flexible cord (code designation 60245 IEC 57))

### NOTES

1. Select and install the power supply wiring in accordance with [IEC 60335-1 (Table 11)] or local laws and regulations. The maximum current of the outdoor and indoor units are shown on each name plate.
2. When installing wiring in a location that can easily come in contact with people, be sure to install an earth leakage breaker coping with high harmonics to prevent electric shock.
3. Breaker type and capacity shall be selected in accordance with local laws and regulations.

### ⚠ CAUTION

#### TO PERSONS INCHARGE OF ELECTRICAL WIRING WORK

- Do not operate the unit until the refrigerant charging is completed. (Running it before the piping is ready will break the compressor.)

## 9 CHECK ITEMS BEFORE TEST OPERATION AND FIELD SETTINGS

### PRE-RUN CHECKS

	ITEM TO CHECK	CHECK
Power supply Wiring	Is the wiring as mentioned on the wiring diagram? make sure no wiring has been forgotten and that there are no missing phases or reverse phases.	
	Does wiring between units put in and changed in continuation installation?	
	Is the unit properly grounded?	
	Are any of the wiring attachment screws loose?	
	Is the insulation resistance at least 1MΩ? • Use a 500V mega-tester when measuring insulation • ※ Do not use a mega-tester for circuits which except 230V.	
	Is an earth leakage circuit breaker used a current operated type which is compatible to the higher harmonic wave?	
	Does the earth leakage circuit breaker have appropriate rated current?	
Refrigerant piping	Is the size of the piping appropriate?	
	Is the insulation material for the piping attached securely? Are both the liquid and gas pipes insulated?	
	Are the stop valves for both the liquid side and the gas side open?	
Extra refrigerant	Did you write down the extra refrigerant and the refrigerant piping length?	
Indoor unit	Is the indoor unit fully installed? When the test run is started, the fan automatically begins turning.	

### WARNING

- When a power supply is switched on, when you leave from the outdoor unit, be sure to close the cover plate.  
(It becomes the cause of an electric shock).

## 10 TEST OPERATION

### WARNING

- Never perform a test operation with the discharge piping thermistor(R2T) condenser thermistor removed, as this might break the compressor.
- If the technician must leave the outdoor unit for some reason, switch places with another installation technician or close the plates. (It may cause electric shocks.)

### HOW TO TEST OPERATION

After the indoor and outdoor unit installation, be sure to perform the test operation in accordance with the following procedure.

1. Open the stop valve cover and check that the liquid and gas sides of the stop valves are open.  
<Be sure to close the front plate before the operation (there is a risk of electric shock)>  
Note: After doing an air-purge with a vacuum pump, the refrigerant pressure may not rise even if the stop valves are opened. This is because the refrigerant piping path is closed off by the outdoor unit electronic expansion valve, etc. There are no problems if the unit is run.
2. Attach the stop valve cover to the outdoor unit and turn the power on at least 6 hours before operating the outdoor unit to protect the compressor.
3. Set to COOLING operation with the remote controller.
4. Perform the test operation.
5. Operate normally
6. Confirm function of the indoor and outdoor units according to the operation manual.

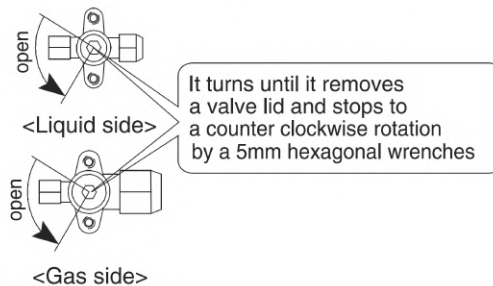

### CAUTION

To persons incharge of piping work and electric work

- Please check having attached the front board and the piping cover after a test run end when giving production over to customer.





# SPLIT SYSTEM AIR CONDITIONER INSTALLATION MANUAL

RZFQ90AV16	RZMFQ90AV16
RZFQ100AV16	RZMFQ100AV16
RZFQ125AY16	RZVFQ125AY16
RZFQ140AY16	RZVFQ140AY16
RZVFQ90AV16	RZMFQ125AY16
RZVFQ100AV16	RZMFQ140AY16

## [For Outdoor unit] New Refrigerant (R32) Series

### CONTENTS

※ SAFETY PRECAUTIONS .....	17
1. BEFORE INSTALLATION .....	19
2. SELECTING INSTALLATION SITE .....	19
3. INSTALLATION SERVICE SPACE .....	20
4. PRECAUTIONS ON INSTALLATION .....	23
5. REFRIGERANT PIPING WORK .....	23
6. AIRTIGHTNESS TEST AND AIR-PURGE .....	26
7. CHARGING REFRIGERANT .....	27
8. ELECTRICAL WIRING WORK .....	28
9. CHECK ITEMS BEFORE TEST OPERATION .....	31
10. TEST OPERATION .....	32

## SAFETY PRECAUTIONS



Read the precautions in this manual carefully before operating the unit.



This appliance is filled with R32.

### ⚠ WARNING THERE IS A RISK OF EXPLOSION OR FIRE

- Do not mix air in the refrigerating cycle during pump down operation.
- Do not use oxygen for air tight test.
- Do not use refrigerant other than the specified one or flammable material ( e.g. propane ) in the refrigerant cycle. They may cause over pressure in the refrigerating cycle and result in explosion, fire or injury. Our company assumes no responsibility for failure or malfunction caused by filling or mixing of anything other than the specified refrigerant.

### ⚠ CAUTION ABOUT ISOLATING RESISTANCE OF COMPRESSOR

If refrigerant accumulates in the compressor after completing installation, the insulation resistance can drop, but if it at least 1 MΩ, then the unit will not break down.



- Connect the power supply to the unit and after 6 hours check if the insulation resistance of the compressor rises. (Energize and heat the compressor to vaporize the refrigerant accumulated in the compressor.)
- If the earth leakage breaker actuates, check if the earth leakage breaker is equipped with a device to cope with high harmonics. To prevent wrong actuation of the earth leakage breaker due to the inverter, make sure to adopt an earth leakage breaker equipped with a device to cope with high harmonics.

1. Please make sure to confirm that R32 (new refrigerant) is used in installation work in advance. (It may not operate normally, if refrigerant type is different.)
2. The refrigerant R32 requires that strict precautions be observed for keeping the system clean, dry and tightly sealed.
  - Clean and dry  
Strict measures must be taken to keep impurities (Including SUNISO oil and other mineral oils as well as moisture) out of the system.
  - Tightly sealed  
R32 contains no chlorine, does not destroy the ozone layer and so does not reduce the earth's protection against harmful ultraviolet radiation. R32 will contribute only slightly to the greenhouse effect if released into the atmosphere. Therefore, sealing tightness is particularly important in installation.  
Carefully read the chapter **5 REFRIGERANT PIPING WORK** and strictly observe the correct procedures.
3. The design pressure of this unit : High/Low pressure area are shown in the right table. (Units: MPa)  
The refrigerant piping is a high pressure area, Use the refrigerant piping which supports the design pressure. The piping specifications, please refer to chapter **5 REFRIGERANT PIPING WORK** .
4. Be sure to connect the indoor unit, which is dedicated to R32. See the catalog for indoor unit models which can be connected. (Normal operation is not possible when connected to other units.)

Outdoor Unit	Design pressure	Cooling
RZM/VFQ90,100AV16 RZM/VFQ125,140AY16	High	4.15
RZFQ90,100AV16 RZFQ125, 140AY16	Low	2.21

## READ THESE INSTRUCTIONS CAREFULLY BEFORE INSTALLATION

- This manual classifies the precautions into WARNINGS and CAUTIONS.  
Be sure to follow all the precautions below. They are all important for ensuring safety.

 <b>WARNING</b>	Indicates a potentially hazardous situation which, if not avoided, could result in death or serious injury.
 <b>CAUTION</b>	Indicates a potentially hazardous situation which, if not avoided, may result in minor or moderate injury. It may also be used to alert against unsafe practices.

- After the installation is completed, test the air conditioner and check if the air conditioner operates properly.  
Give the user adequate instructions concerning the use and cleaning of the indoor unit according to the operation manual.  
In particular, make sure to explain with regard to "SAFETY PRECAUTIONS" and "Not malfunction of the air conditioner".  
Ask the user to keep this manual and the operation manual together in a handy place for future reference.
- This air conditioner comes under the term "appliances not accessible to the general public".

### **WARNING**

- Ask your local dealer or qualified personnel to carry out installation work.  
Improper installation may result in water leakage, electric shocks or a fire.
- Perform installation work in accordance with this installation manual.  
Improper installation may result in water leakage, electric shocks or a fire.
- Consult your local dealer regarding what to do in case of refrigerant leakage.  
When the indoor unit is installed in a small room, it is necessary to take proper measures so that the amount of any leaked refrigerant does not exceed the concentration limit in the event of a leakage. Otherwise, this may lead to an accident due to oxygen deficiency.
- Be sure to use only the specified parts and accessories for installation work.  
Failure to use the specified parts may result in the air conditioner fall down, water leakage, electric shocks, a fire, etc.
- Install the air conditioner on a foundation that can withstand its mass.  
Insufficient strength may result in the air conditioner fall down and causing injury.
- Carry out the specified installation work in consideration of strong winds, typhoons, or earthquakes.  
Improper installation may result in an accident such as the air conditioner falling.
- Make certain that all electric work is carried out by qualified personnel according to the applicable legislation (note 1) and this installation manual, using a separate circuit. In addition, even if the wiring is short, make sure to use a wiring that has sufficient length and never connect additional wiring to make the length sufficient. Insufficient capacity of the power supply circuit or improper electric construction may lead to electric shocks or a fire.  
(note 1) Applicable legislation means "All international, national and local directives, laws, regulations and/or codes which are relevant and applicable for a certain product or domain."
- Earth the air conditioner. Do not connect the earth wiring to gas or water piping, lightning conductor or telephone earth wiring. Incomplete earthing may cause electric shocks or a fire. 
- Be sure to install an earth leakage circuit breaker. Failure to do so may cause electric shocks or a fire.
- The appliance must be stored in a room without continuously operating ignition sources (for example : open flames, an operating gas appliance or an operating electric heater).
- Do not pierce or burn.
- Be aware that refrigerant may not contain an odour.
- Comply with national gas regulations.
- Be sure to switch off the unit before touching any electrical parts. Touching a live part may result in electric shocks.
- Make sure that all wiring is secure, using the specified wiring and ensuring that external forces do not act on the terminal connections or wiring. Incomplete connection or fixing may cause overheating terminals or fire.
- When wiring between the outdoor and indoor units, and wiring the power supply, from the wiring orderly so that the structural parts such as a cover can be securely fastened. If the cover is not in place, electric shocks or a fire may be caused.
- Do not add wiring. It may result in heat generation. Electric shocks or fire.
- When installing or relocating the air conditioner, be sure to bleed the refrigerant circuit to ensure, it is free of air, and use only the specified refrigerant (R32). The presence of air or other foreign matter in the refrigerant circuit causes abnormal pressure rise, which may result in equipment damage and even injury.
- If refrigerant gas leaks during installation work, ventilate the area immediately.  
Toxic gas may be produced if refrigerant gas comes into contact with a fire.
- After completing the installation work, check to make sure that there is no leakage of refrigerant gas.  
Toxic gas may be produced if refrigerant gas leaks into the room and comes into contact with a source of a fire, such as a fan heater, stove or cooker.
- Never directly touch any accidental leaking refrigerant. This could result in severe wounds caused by frostbite.
- Do not stand on the outdoor unit or put things on it. The unit may fall down or drop, and cause accidents.
- Do not charge any refrigerant into the refrigeration cycle other than the designated refrigerant.  
It may cause an explosion or a fire due to leakage or a burst due to abnormally high pressure in the refrigeration cycle.
- Do not extend wiring on the way. It may cause heat generation, electric shocks or fire.
- At the installation work, install the refrigerant piping firmly before operating the compressor.  
If the compressor is operated without installing firmly and the service valve is in open condition, it sucks the air, etc., and the pressure inside the refrigerant circle becomes abnormally high. It may cause injury and breakage.
- At pump down work, stop the compressor before removing the refrigerant piping.  
If removing the refrigerant piping when the compressor is operated with its service valve in open condition, it sucks the air, etc., and the pressure inside the refrigerant circle become abnormally high, which may cause injury and breakage.
- The appliance shall be installed, operated and stored in a room with floor area larger than  $-m^2$ .  
\* Since the maximum refrigerant charge of the models is below 1.75kg, it does not have any limitation for the minimum floor area.
- When flared joints are reused indoors, the flare part shall be re-fabricated.

## ⚠ CAUTION

- Install drain piping according to this installation manual to ensure good drainage, and insulate the piping to prevent condensation. Improper drain piping may cause water leakage, make the furniture get wet.
- Install the indoor and outdoor units, power cord and connecting wires at least 1 meter away from televisions or radio to prevent picture interference and noise. (Depending on the incoming signal strength, a distance of 1 meter may not be sufficient to eliminate noise.)
- Install the indoor unit as far as possible from fluorescent lamps. If a wireless remote controller kit is installed, the transmission distance of the remote controller may be shorter in a room where an electronic lighting type (inverter or rapid start type) fluorescent lamp is installed.
- In a domestic environment this product may cause radio interference in which case the user may be required to take adequate measures.
- Make sure to provide for adequate measures in order to prevent that the outdoor unit be used as a shelter by small animals. Small animals making contact with electrical parts can cause malfunctions, smoke or fire. Please instruct the customer to keep the area around the unit clean.
- Disposal requirements  
Dismantling of the unit, treatment of the refrigerant, of oil and of other parts must be done in accordance with relevant local and national legislation.
- Only qualified personnel can handle, fill, purge and dispose of the refrigerant.
- Do not install the air conditioner in places such as following:
  1. Where there is mist of oil, oil spray or vapor for example a kitchen.  
Resin parts may deteriorate, and cause them to fall out or water to leak.
  2. Where corrosive gas, such as sulfurous acid gas, is produced.  
Corrosion of copper pipings or brazed parts may cause the refrigerant to leak.
  3. Where there is machinery which emits electromagnetic waves. Electromagnetic waves may disturb the control system, and cause malfunction of the equipment.
  4. Where flammable gases may leak, where carbon fiber or ignitable dust is suspended in the air or where volatile flammables, such as thinner or gasoline, are handled.  
If the gas should leak and remain around the air conditioner, it may cause ignition.
  5. The place that the vibration or the voltage fluctuation give influence. Vehicles, vessels, etc.  
The vibration may cause a damage and the voltage fluctuation may cause an abnormal operation.
  6. Where small animals may build a nest, fallen leaves are accumulated, or weeds are overgrown.  
If small animals touch the electrical parts inside, this may cause malfunction, smokes or a fire.

■ Important information regarding the refrigerant used.  
This product contains fluorinated greenhouse gases. Do not vent gases into the atmosphere.  
Refrigerant type: R32  
GWP<sup>(1)</sup> value: 675  
(<sup>1</sup>)GWP = global warming potential  
• The refrigerant quantity is indicated on the unit name plate.

## 1 BEFORE INSTALLATION

- Do not throw away accessories for installation.

### HANDLING

As shown in the figure, bring the unit slowly by grabbing the left and right grips.  
(Take care not to let hands or objects come in contact with rear fins.)

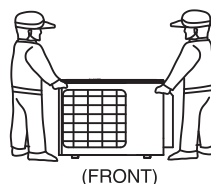
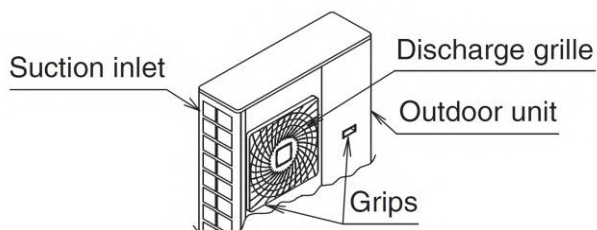
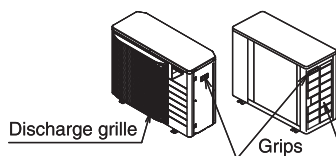

Place your hands on the corner instead of holding the suction inlet in the side of the casing, otherwise the casing could be deformed.

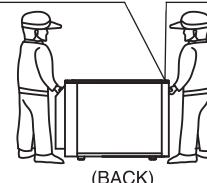

Place your hands on the corner instead of holding the suction inlet in the side of the casing, otherwise the casing could be deformed.

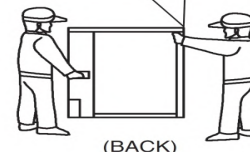
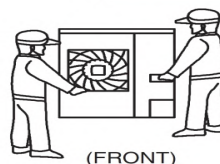

### INSTALLATION CONSTRUCTION ACCESSORIES

Be sure only to use accessories made by DAIKIN which are specifically designed for use with the equipment.

### CAUTION

Work in a team of at least two people when carrying the outdoor unit.

## 2 SELECTING INSTALLATION SITE (1/2)

1. Select the installation location that meets the following conditions and get approval of the customer.
  - Places where is no risk of flammable gas leakage.
  - Places where the outdoor unit does not bother next-door neighbors.
  - Safe places where can withstand the unit's mass and vibration and where the air conditioner can be installed level.
  - Places where are well-ventilated and where servicing space can be well ensured.  
The minimum required space is shown in chapter **3 INSTALLATION SERVICE SPACE**.
  - Where the piping length between the indoor and the outdoor units is ensured within the allowable piping length. (Please see chapter **5 REFRIGERANT PIPING WORK**)
  - Do not allow wind from the same direction to blow frequently toward the outlet or inlet of the outdoor unit.

If the wind is likely to blow as mentioned above, make sure to keep a sufficient service space and install a wind protective shield.

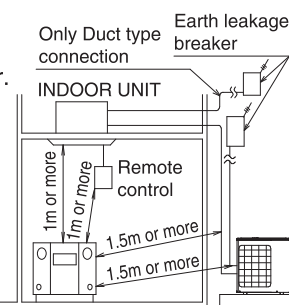

### ⚠ CAUTION

Inverter air conditioners may cause noise to occur in electrical appliances. As shown in the right drawing, select an installation site well away from radios, PCs, and stereos.  
Especially in the areas where the incoming signal strength is weak, keep the indoor remote controller 3 meter or more from electrical appliances. Put the power supply and transmission wiring in a metal piping and ground the metal piping.

## 2 SELECTING INSTALLATION SITE (2/2)

### CAUTION

- In a domestic environment this product may cause radio interference in which case the user may be required to take adequate measures.
- When installing the unit in a place exposed to strong wind, pay special attention to the following. Strong winds of 5 m/sec or more blowing against the outdoor unit's air outlet causes short circuit (suction of discharge air) and this may have the following consequences:
  - Deterioration of the operational capacity.
  - Disruption of operation due to rise of high pressure.
  - When a strong wind blows continuously on the face of the unit, the fan can start rotating very fast until it breaks.
 Refer to the figures for installation of this unit in a place where the wind direction can be foreseen.
- Following the installation place, it is expected that the influence of the strong wind is great.
  - The flat area which receives the adverse wind such as typhoon directly since there is no obstacles such as buildings and mountains. (Including coast line, shoreline of lake and mountain region.)
  - The installation place that no obstacles around the outdoor unit to prevent the adverse wind, for example, walls and buildings that are higher than the applicable outdoor unit, etc. Please take measures when installing especially on a rooftop.
  - Since the outdoor unit may fall down, attach the fixture for preventing overturning (option).

Turn the air discharge toward the building's wall fence or screen.

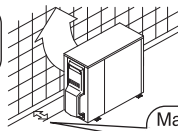

Make sure there is enough room to do the installation

STRONG WIND

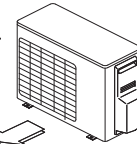

Set the outlet side at right angle to the direction of the wind.

AIR DISCHARGE

STRONG WIND

- Prepare a water drainage channel around the foundation, to drain waste water from around the unit.
- If the water drainage of the unit is not easy, please build up the unit on a foundation of concrete blocks, etc. (the height of the foundation should be maximum 150 mm).
- If you install the unit on a frame, please install a waterproof plate within 150 mm of the underside of the unit in order to prevent the invasion of water from the lower direction.

## 3 INSTALLATION SERVICE SPACE (1/3)

- The installation servicing spaces shown in these drawings are based on the outdoor unit inlet area temperature of 35°C(DB) for COOLING operation. If the planned inlet area temperature exceeds 35°C(DB), or if the heat load of all outdoor units is increased significantly and exceeds the maximum operating capacity, secure a larger space than that indicated by the inlet dimensions in these drawings.
- For installation, consider both pedestrian and air flow paths and choose a suitable pattern from these drawings to match the space available field. (If the number of units to be installed exceeds the patterns in these drawings, consider there is nothing short-circuits.)
- Regarding the front space, position the units with consideration to the space required for the refrigerant piping work. (Consult your dealer if the work conditions do not match those in the drawings.)
- Secure appropriate space when using a side piping outlet.

### STAND-ALONE INSTALLATION

- To secure service space, more than 250 mm on the right side of each unit is necessary.

(Units: mm)

#### No obstacle above

##### 1. Obstacle on the suction side only

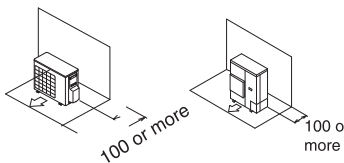

##### 2. Obstacle on both sides and suction side, too

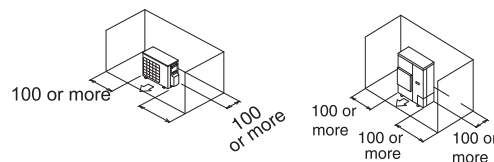

##### 3. Obstacle on the discharge side only

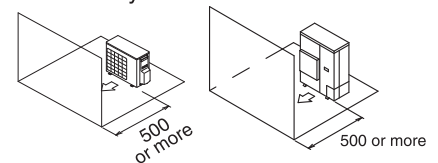

#### Obstacle above, too

##### 1. Obstacle on the suction side, too

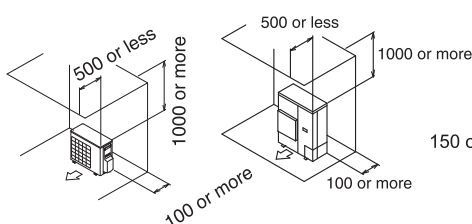

##### 2. Obstacle on both sides and suction side, too

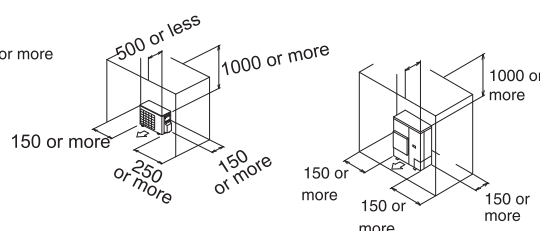

##### 3. Obstacle on the discharge side only, too

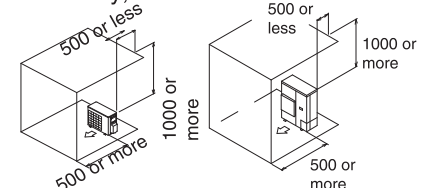

### 3 INSTALLATION SERVICE SPACE (2/3)

(Units: mm)

When there are obstacles on both suction and discharge sides

- To secure service space, more than 250 mm on the right side of each unit is necessary.

**Pattern 1** When the obstacles on the discharge side is higher than the unit

1. No obstacle above (There is no limit for the height of obstructions on the suction side.)

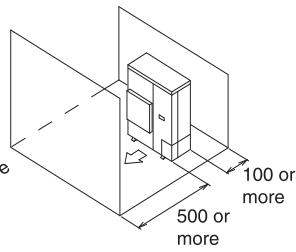
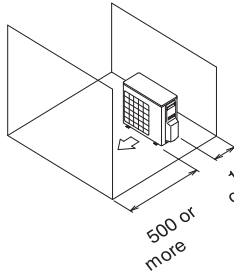

2. Obstacle above, too

The relations between H, A and L are as follows.

	L	A
$L \leq H$	$L \leq 0.5H$	750 or more
	$0.5H < L \leq H$	1000 or more
$L > H$	Set the stand as: $L \leq H$	

- Close the bottom of the stand to prevent the discharged air from being bypassed.
- The limitation of facilities connection is until 2 unit only.

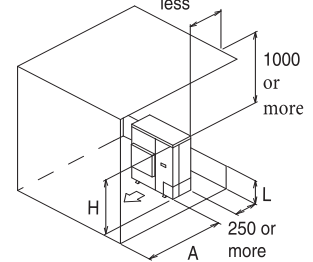
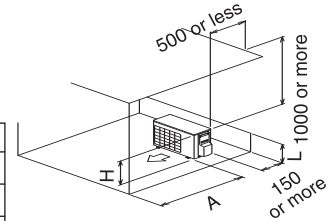

**Pattern 2** When the obstacle on the discharge side is lower than the unit

1. No obstacle above (There is no limit for the height of obstructions on the suction side.)

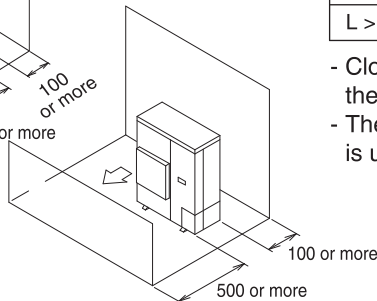
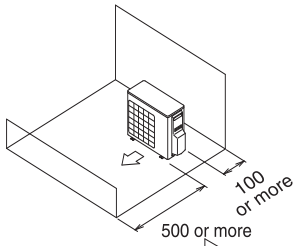

2. Obstacle above, too

The relations between H, A and L are as follows.

	L	A
$L \leq H$	$L \leq 0.5H$	100 or more
	$0.5H < L \leq H$	100 or more
$L > H$	Set the stand as: $L \leq H$	

- Close the bottom of the stand to prevent the discharged air from being bypassed.
- The limitation of facilities connection is until 2 unit only.

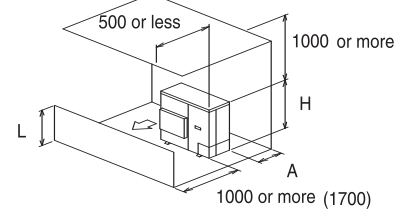
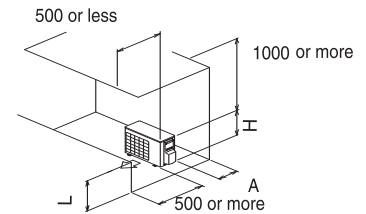

#### SERIES INSTALLATION ( 2 OR MORE )

- To secure service space, more than 250 mm on the right side of each unit is necessary.

(Units: mm)

No obstacle above

1. Obstacle on the suction side and both sides

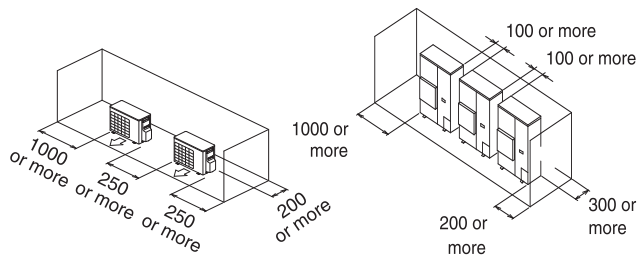

2. Obstacle on the discharge side only

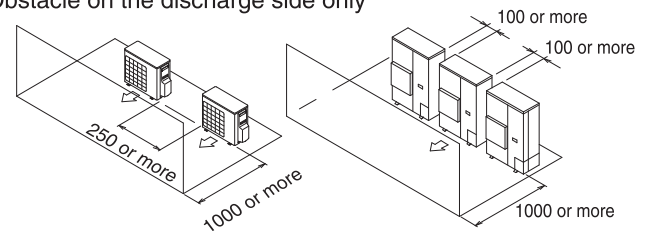

Obstacle above, too

1. Obstacle on the discharge side

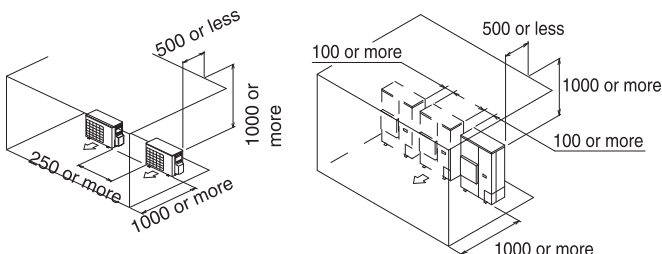

2. Obstacle on the suction side and both sides

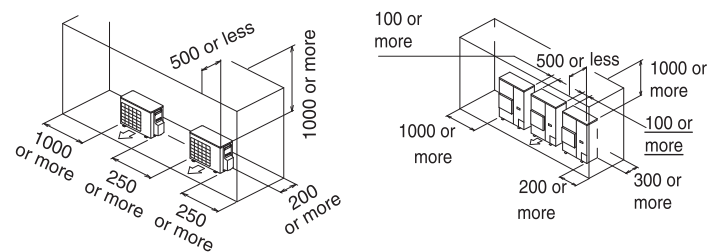

### 3 INSTALLATION SERVICE SPACE (3/3)

When there are obstacles on both suction and discharge sides

- To secure service space, more than 250 mm on the right side of each unit is necessary.

**Pattern 1** When the obstacles on the discharge side is higher than the side unit

1. No obstacle above (There is no limit for the height of obstructions on the suction side.)

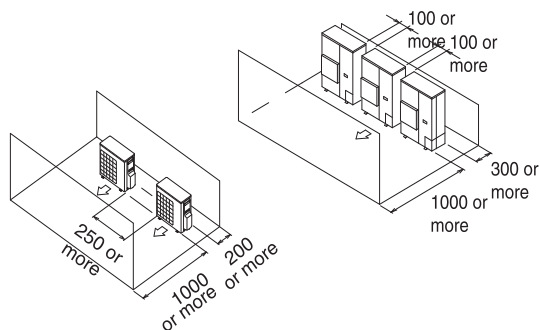

2. Obstacle above, too  
The relations between H, A and L are as follows.

	L	A
$L \leq H$	$L \leq 0.5H$	1000 or more
	$0.5H < L \leq H$	1250 or more
$L > H$	Set the stand as: $L \leq H$	

- Close the bottom of the stand to prevent the discharged air from being bypassed.
- The limitation of facilities connection is until 2 unit only.

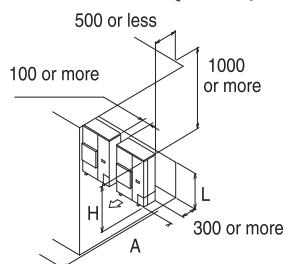
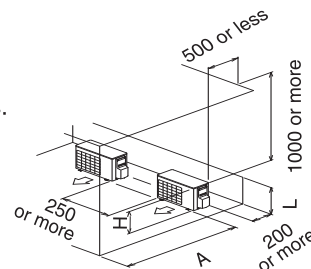

**Pattern 2** When the obstacle on the discharge side is lower than the unit

1. No obstacle above (There is no limit for the height of obstructions on the suction side.)

The relations between H, A and L are as follows.

L	A
$L \leq 0.5H$	150 or more
$0.5H < L \leq H$	200 or more

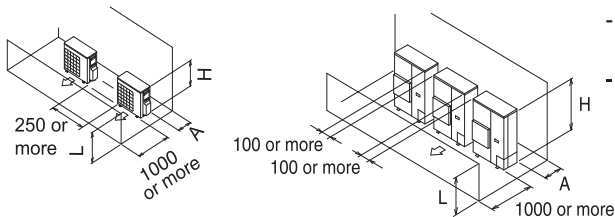

2. Obstacle above, too  
The relations between H, A and L are as follows.

	L	A
$L \leq H$	$L \leq 0.5H$	150 or more
	$0.5H < L \leq H$	200 or more
$L > H$	Set the stand as: $L \leq H$	

- Close the bottom of the stand to prevent the discharged air from being bypassed.
- The limitation of facilities connection is until 2 unit only.

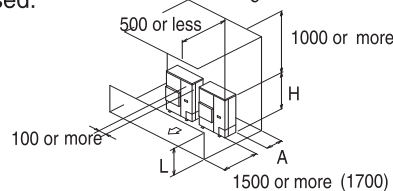
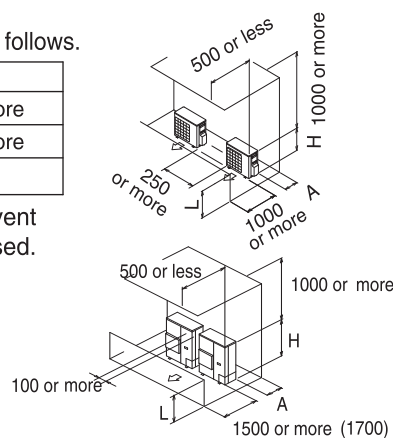

#### DOUBLE-DECKER INSTALLATION

- Do not stack more than two unit.
- The drain piping construction size of upper side outdoor unit is needed about 100 mm.
- In side extraction, please provide the space of piping.

1. Obstacle on the discharge side

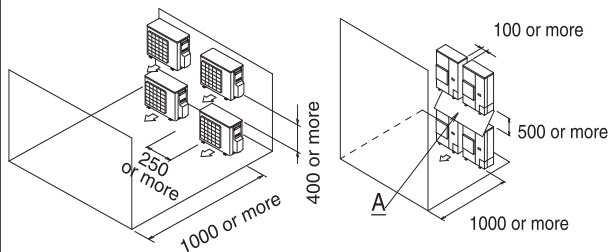

2. Obstacle on the suction side

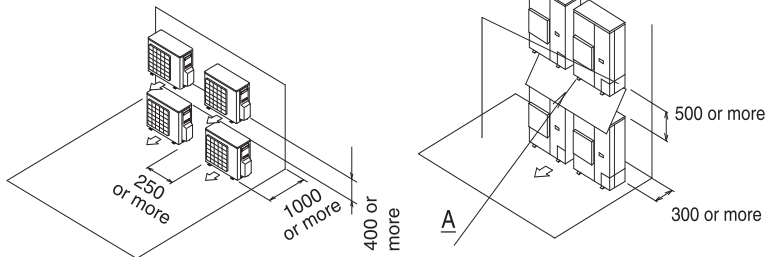

#### MULTIPLE ROWS OF SERIES INSTALLATION (ON THE ROOFTOP, ETC.)

1. One row of stand-alone installation

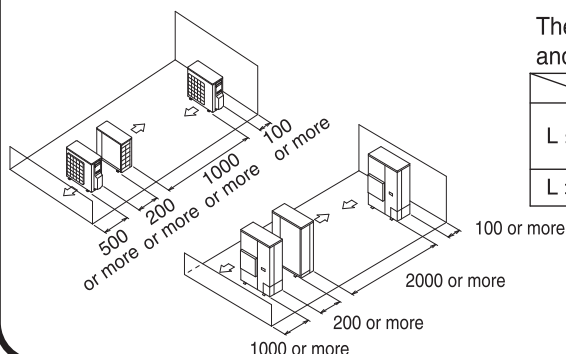

2. Rows of series installation (2 or more)

The relations between H, A and L are as follows.

	L	A
$L \leq H$	$L \leq 0.5H$	150 or more
	$0.5H < L \leq H$	200 or more
$L > H$	Can not be installed	

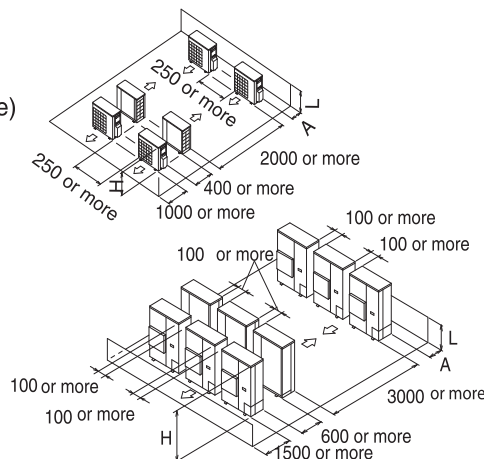

## 4 PRECAUTIONS ON INSTALLATION

- Check the strength and level of the installation ground so that the unit will not cause any operating vibration or noise after installed.
- In accordance with the foundation drawing in **Fig. 1**, fix the unit securely by means of the foundation bolts. (Prepare 4 sets of M8 or M10 foundation bolts, nuts and washers each which are available on the market.)
- It is best to screw in the foundation bolts until their length are 20 mm from the foundation surface.
- Fix the outdoor unit to the foundation bolts using nuts with resin washers. (See **Fig. 1**)  
If the coating on the fastening area is stripped off, the nuts rust easily.

### <Drain work disposal>

- If drain work disposal from the outdoor unit causes trouble, (for example, if the drain water may splash on people) provide the drain piping by using of the drain plug (optional).
- Then, coat the area around the bored holes with rust preventive coating to cover the metal exposure.
- Make sure the drain works properly.

### <Installation method of fixture for preventing overturning>

- If steps need to be taken to prevent the unit from tipping over, use the fixture for preventing overturning (option).

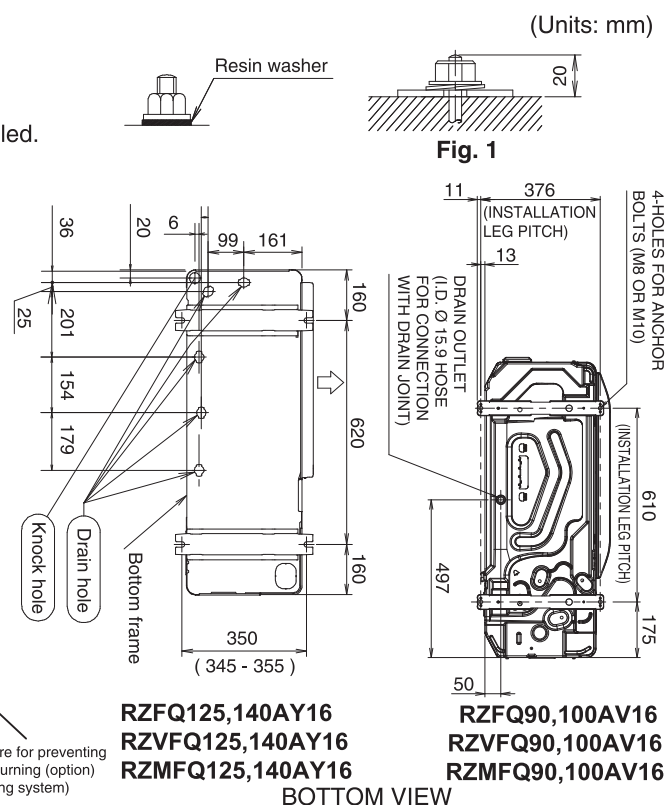
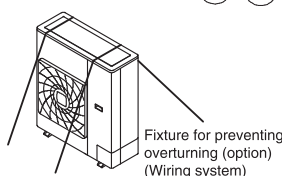

## 5 REFRIGERANT PIPING WORK (1/4)

### ⚠ CAUTION

#### To plumbing person

- Important information regarding the refrigerant used. This product contains fluorinated greenhouse gases.  
Do not vent gases into the atmosphere.  
GWP (global warming potential) of R32 refrigerant type = 675
- Use R32 as additional for charging.
- Do not use flux when brazing refrigerant piping.  
Use phosphor copper brazing filler metal (BCuP-2:JIS Z 3264/B-Cu93P-710/795:ISO 3677) that does not require flux.  
(If chlorinated flux is used, the piping will be corroded and, in addition if fluorine is contained, the refrigerant oil will be deteriorated and the refrigerant circuit will be affected badly.)
- After chapter **7 CHARGING REFRIGERANT** is completed, be sure to open the stop valves before performing **9 LOCAL SETUP**.  
(Operating the unit with the valve shut will break the compressor.)

#### 5-1 INSTALLATION TOOLS

Be sure to use the dedicated tools to ensure sufficient pressure resistance and prevent the entry of any impurities.

Manifold gauge Charging hose	To ensure sufficient pressure resistance and prevent the entry of any impurities (mineral oils such as Suniso oil and liquids), use the R410A or R32 dedicated item (the screw specifications for R410A or R32 differ).
Vacuum pump	Be extremely careful not to flow the pump oil backward to inside the piping when the pump is stopped. Use a pump which enables vacuuming to -0.1 MPa (-755mmHg) of the gauge pressure.

#### 5-2 SELECTION OF PIPING MATERIAL

- Use the piping whose inside and outside are clean and with no harmful substances for use such as sulphur, oxide, dust, dust from cutting, grease, or liquid (contamination) is attached.
- For the refrigerant piping, use the following material.

**Material:** Deoxidised phosphorous seamless copper piping

**Temper grade:** Use piping with temper grade in function of piping diameter as listed in the table on section

**5-4 REFRIGERANT PIPE SIZE AND ALLOWABLE PIPE LENGTH**

**Size:** Decide based on section **5-4 REFRIGERANT PIPE SIZE AND ALLOWABLE PIPE LENGTH**

**Thickness:** Comply with applicable legislation. The minimal piping thickness for R32 piping must be in accordance with the table on section **5-4 REFRIGERANT PIPE SIZE AND ALLOWABLE PIPE LENGTH**

- Be sure to perform piping work using measurements within the maximum allowable length and height difference described on section **5-4 REFRIGERANT PIPE SIZE AND ALLOWABLE PIPE LENGTH**

## 5 REFRIGERANT PIPING WORK (2/4)

<Please refer to installation manual of indoor unit about indoor unit's refrigerant piping>

### 5-3 CARE OF PIPE

- Prevent contamination or moisture from getting into the piping.
- Pay special attention when running the copper piping through the through-hole or when leading the edge of the piping outside the room.
- Refrigerant piping must be protected from physical damage. Install a plastic cover or equivalent.

PLACE	INSTALLATION PERIOD	PROTECTION METHOD	PLACE	INSTALLATION PERIOD	PROTECTION METHOD
OUTDOOR	More than a month	Pinch the pipe	INDOOR	Unquestioned	Pinch or tape pipe
	Less than a month	Pinch or tape pipe			

### 5-4 REFRIGERANT PIPE SIZE AND ALLOWABLE PIPE LENGTH

- Maximum allowable piping length means the maximum length of liquid side piping or gas side piping.
- Equivalent length is the pressure loss due to L joints, traps, and so on along the refrigerant piping converted to a straight piping length of the same size and added to the overall value.  
Please see the Engineering Data for calculation of equivalent length.
- Please give the vertical interval between the indoor and outdoor as 30 m or less.

#### ⚠ CAUTION

- This unit is chargeless specification. Due to chargeless length and allowable piping length will be different depend on field pipe size.

#### Piping bend radius

Piping diameter	Pipe thickness (material)	Bend radius
Ø 9.5mm	0.8 mm (C1220T-O, Type O)	30mm or more
Ø 15.9mm	1.0 mm (C1220T-O, Type O)	50mm or more

#### Refrigerant pipe size and chargeless length

Outdoor unit type	Liquid pipe size (type)	Chargeless length
RZV/MFQ90,100AV16 RZV/MFQ90,100AV16 RZV/MFQ125,140AY16 RZV/MFQ125,140AY16	Ø 9.5 mm x t 0.8 mm (type O)	15 m

#### ⚠ WARNING

When flared joints are reused indoors, the flared part shall be re-fabricated.

#### ⚠ CAUTION

- Use dedicated piping cutters and flaring tools for R410A or R32.
- When making a flare connection, apply ether or ester oil only to the flare inner surface.
- Use only the flare nuts attached to the unit. If other flare nuts are used, it may cause refrigerant leakage. To prevent contamination, dust or moisture from getting into the piping, take measures such as pinching or taping the piping.

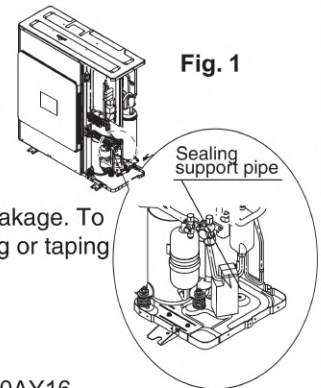

### 5-5 CONSTRUCTION OF REFRIGERANT PIPING

- Make sure to take out the sealing support pipe, before have refrigerant piping work. (See Fig. 1)
- The refrigerant piping is connectable in four directions for RZV/MFQ125,140AY16 & RZV/MFQ125,140AY16. (See Fig. 3)
- The refrigerant piping can be connected from backside for RZV/MFQ90,100AV16 & RZV/MFQ90,100AV16. (See Fig. 2)
- Do not let anything other than the designated refrigerant (such as air or water) enter the refrigerant system.
- When connecting in a downward direction, open the knock out hole by making 4 round holes around the knock out hole by using a Ø 6 mm drill. (See Fig. 4)
- Cutting out the two slits makes it possible to install as shown in Fig. 5. (Use a metal saw to cut out the slits.)

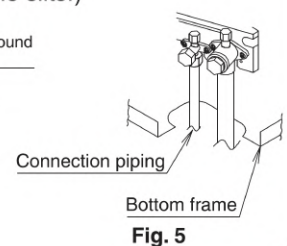
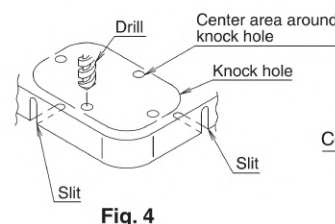
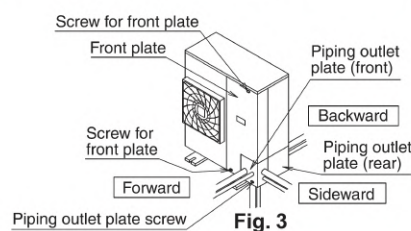
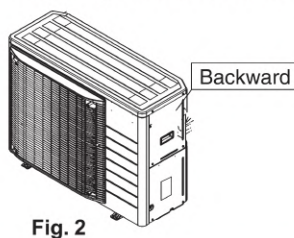



## 5 REFRIGERANT PIPING WORK (3/4)

<Please refer to installation manual of indoor unit about indoor unit's refrigerant piping>

**Back side (rear) connection** Remove the piping outlet plate (rear) for connection.

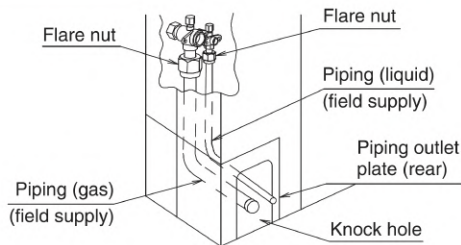

**Side (lateral) connection** Remove the piping outlet plate (front) for connection.

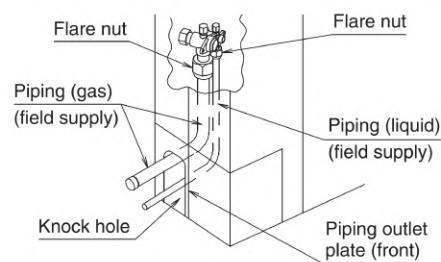

### Preventive against small animals entering into the casing

Fill up the space with putty or thermal insulation (field supply) where the piping through as shown Fig. 6.  
(If small animals touch the electrical parts inside, this may cause malfunction, smokes or a fire.)

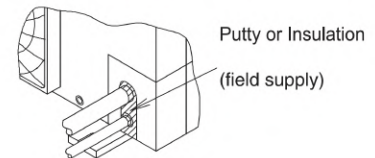

Fig. 6

### CAUTIONS FOR HANDLING STOP VALVE

**DO NOT OPEN THE STOP VALVE UNTIL CHARGING REFRIGERANT FINISHED.**

- The stop valves for indoor-outdoor connecting piping are closed at shipment from the factory.
- Since the side boards may be deformed if only a torque wrench is used when loosening or tightening flare nuts, always lock the stop valve with a wrenches and then use a torque wrench.

Refrigerant piping must be protected from physical damage. Install a pipe cover or equivalent.

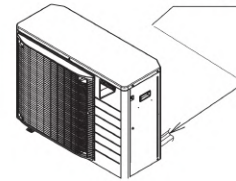

When tightening the flare of the stop valves, make sure to tighten by the rated torque. The rated torque is shown on **CAUTION FOR FLARE CONNECTION** (Following)

**DO NOT APPLY FORCE ON THE VALVE CAP, THIS MAY RESULT IN A REFRIGERANT LEAK.**

- For cooling operation under low ambient temperature or any other operation under low pressure, apply silicon sealant or similar to prevent freezing of the gas stop valve flare nut (see figure).

Freezing of the flare nut may cause refrigerant leak.

#### How to operate the stop valve

Use hexagonal wrenches 4mm and 6mm.

**Opening the valve** 1. Place the hex wrench on the valve bar and turn counter-clockwise.  
2. Stop when the valve bar no longer turns. (It is now open.)

**Closing the valve** 1. Place the hex wrench on the valve bar and turn clockwise.  
2. Stop when the valve bar no longer turns. (It is now close.)

### CAUTIONS FOR HANDING VALVE CAP

- A seal is attached to the point indicated by the arrow. Take care not to damage it.
- Be sure to tighten the valve cap securely after operating the valves.

	Valve size (mm)	Tightening torque (N·m)		Valve size (mm)	Tightening torque (N·m)
Liquid side	Ø9.5	15.0 ± 1.5	Gas side	Ø15.9	25.0 ± 2.5

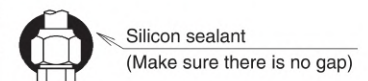

### CAUTIONS FOR HANDLING SERVICE PORT

- Always use a flexible charge hose with a push-rod and valve to enable recovery of remaining refrigerant in the charge hose.
- After the work, tighten the valve cap in place.

Tightening torque:  $12.7 \pm 1.2$  N·m

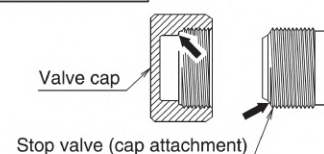

## 5 REFRIGERANT PIPING WORK (4/4)

### PRECAUTIONS FOR CONNECTING PIPING

(RZV/MFQ125, 140AY16/RZFQ125,140AY16)

- Take of a sealing for transportation before connect the connecting pipe.
- Take caution so that the refrigerant piping between the outdoor and indoor may not touch and sound proof cover and the plate as shown figure.
- If installing the outdoor unit higher than the indoor unit, caulk the space around insulation and tubes because condensation on the stop valves can seep through to the indoor unit side.

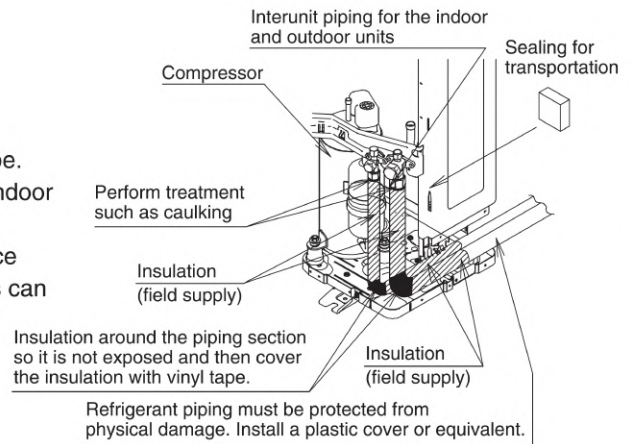

### CAUTION FOR FLARE CONNECTION

- Be sure to remove the flare nuts using two spanners. Then after the piping connection, tighten them using a spanner and torque wrench.
- Refer to the following table for a flare part processing size.
- When connecting the flare nut, apply refrigerating machine oil to the flare (inside) and at first screw the nut 3 or 4 turns by hand. Coat here with ether or ester oil.
- Refer to the table in indoor installation manual (Refrigerant Piping Work) for the dimensions for processing flares and for the tightening torques. (Too much tightening will end up in splitting of the flare.) After completing the installation, carry out a gas leak inspection of the piping connections with nitrogen and such.
- If a torque wrench is not available, be aware that the tightening torque may increase suddenly. Do not tighten nuts any further than to the angle as listed.
- When work is completed, be sure to check that there is no gas leakage.
  1. A flare nut is bound tight with a spanner to the position whose torque with a bundle increases suddenly.
  2. Only the angle of a right table is further bound tight from the position.

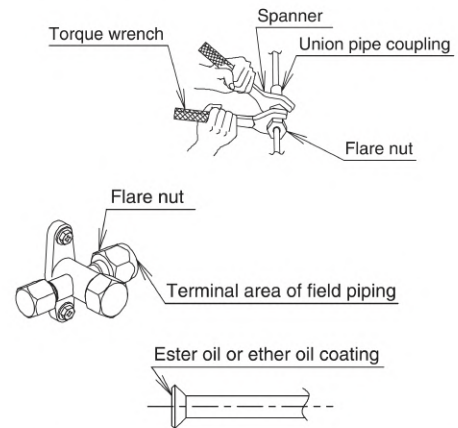

PIPING SIZE (mm)	FURTHER TIGHTENING ANGLE	RECOMMENDED ARM LENGTH OF TOOL
Ø9.5	60 to 90 degrees	About 200 mm
Ø15.9	30 to 60 degrees	About 300 mm

### PRECAUTIONS WHEN BRAZING THE REFRIGERANT PIPINGS

<Do not reuse joint which have been used once already>

- When brazing the refrigerant piping, carry out brazing work (NOTE 2) after substituting nitrogen for air (flow nitrogen into the piping and substitute nitrogen for air (NOTE 1) (see the drawing below)).

#### NOTES

1. The proper pressure for having nitrogen flow through the piping is approximately 0.02MPa, a pressure that makes one feel like breeze and can be obtained through a pressure reducing valve.
2. Do not use flux when brazing refrigerant piping. Use phosphor copper brazing filler metal (BCuP-2:JIS Z 3264/B-Cu93P-710/795:ISO 3677) that does not require flux. (If chlorinated flux is used, the piping will be corroded and, in addition if fluorine is contained, the refrigerant oil will be deteriorated and the refrigerant circuit will be affected badly.)

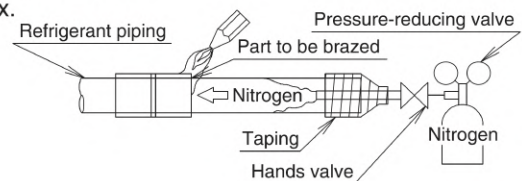

Prohibited

Do not use anti-oxidants when brazing the piping joints. (Residue can clog pipes and break equipment.)

## 6 AIRTIGHTNESS TEST AND AIR-PURGE

### AIRTIGHTNESS TEST

- Perform a refrigerant leakage check using nitrogen gas (airtightness test) with the outdoor unit stop valve close, to make sure there are no leakage.
- For the airtightness test, raise the pressure to the design pressure in the high pressure section (4.15/4.17 MPa). For the airtightness test, the unit passes the test if the pressure in the high pressure section does not drop for 24 hours after increasing to the design pressure. A correction is required since the pressure decreases approx. 0.01MPa when the ambient temperature of 1°C decreases.
- If the pressure drop is confirmed, perform the airtightness test again after checking and modifying the leakage points.

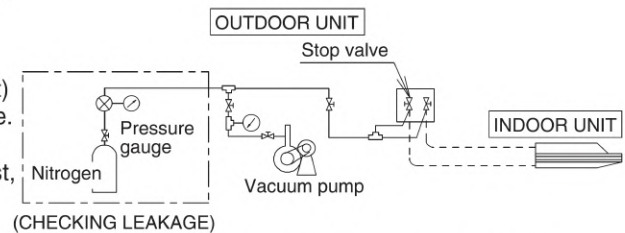

### AIR-PURGE

- Evacuate by the vacuum pump for more than 2 hours until the internal pressure decreases below -0.1MPa. After that, leave it with -0.1MPa or less for more than 1 hour and confirm that the value of vacuum gauges does not increase.

## PRECAUTIONS FOR CONNECTING PIPING

- If installing the outdoor unit higher than the indoor unit, caulk the space around insulation and tubes because condensation on the stop valves can seep through to the indoor unit side.



**Prohibited**

Do not use a charging hose of which pressing stick is slipped out from the center. (It may cause refrigerant leakage due to deformation of the valve stem of the service port)

## PRECAUTION REGARDING INSULATION

Enhance the insulation of the refrigerant piping according to the installation conditions. If this is not done, condensation may form on the surface of the insulation. Please refer to the target values shown below.

- When the temperature and humidity conditions are 30°C and RH 75% or more: thickness of the insulation is 15 mm or more.
- When the temperature and humidity conditions are 30°C and RH 80% or more: thickness of the insulation is 20 mm or more.
- Be sure to insulate the liquid and gas sides interunit piping. It may become the cause of refrigerant leakage if it does not insulate. (Be sure to use insulating material which can resistant.)

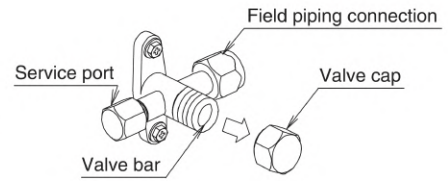

Insulation of interunit piping must be carried out up to the connection inside the casing. If the piping is exposed to the atmosphere, it may cause sweating or burn due to touching the piping, electric shocks or a fire due to the wiring touching the piping.

## 7 CHARGING REFRIGERANT (1/2)

< Be sure to use R32 as refrigerant. >

### ADDITIONAL REFRIGERANT CHARGING

This model is chargeless type, so it is not necessary to charge additionally if pipe does not exceed the maximum allowable length without additional charge.

Please refer to the following table about the maximum allowable length without additional charge.

When piping length exceeds its of a top table, or only when you perform recharging, Please be correctly charged according to the following. For future servicing, please describe the amount of additional refrigerant charging, or the amount of recharging in the collective label in back side of right side plate.

#### • In case of additional refrigerant charging

Please select the amount of additional refrigerant which suited piping length from the following table.

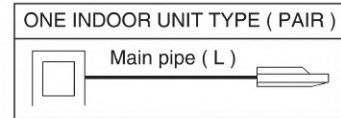

Outdoor units type	Liquid piping size	Length for which additional charging is not required	Length of piping exceeding the length for which additional charging is required, R32 additional amount (kg)				
			15m or less	25m or less	30m or less	35m or less	50m or less
RZV/MFQ90,100AV16	Ø9.5 mm x t0.8 mm	15m	No Extra Charge	0.25	N/A	0.5	0.75
RZV/MFQ90,100AV16			No Extra Charge	0.25	0.375	N/A	N/A
RZV/MFQ90,100AV16			No Extra Charge	0.25	N/A	0.5	0.75

#### • Total refrigerant charging (When recharging due to exchange compressor, etc.)

Please charge refrigerant base on pipe length mentioned in the following table.

Outdoor units type	Liquid piping size	Piping length, R32 complete additional amount (kg)					
		5m~10m	15m or less	25m or less	30m or less	35m or less	50m or less
RZV/MFQ90,100AV16	Ø9.5 mm	1.0	1.0	1.25	N/A	1.5	1.75
RZV/MFQ90,100AV16		1.30	1.30	1.55	1.675	N/A	N/A
RZV/MFQ90,100AV16		1.35	1.35	1.60	N/A	1.85	2.1

#### Refrigerant charge label

Please fill in with indelible ink,

- ① the factory refrigerant charge of the product,
- ② the additional refrigerant amount charged in the field and
- ① + ② the total refrigerant charge

on the refrigerant charge label supplied with the product.

Affix the refrigerant charge label near the manufacturer's label after filling it out.

The filled out label must be adhered in the proximity of the product charging port.

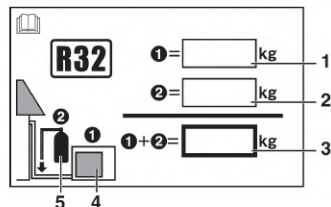

1. factory refrigerant charge of the product: see unit name plate
2. additional refrigerant amount charged in the field
3. total refrigerant charge
4. outdoor unit
5. refrigerant cylinder and manifold for charging

- If the value of vacuum gauge increases, there is moisture inside the refrigerant piping or there are leakage points. Perform evacuation again after checking and improving the leakage points.

**NOTE**

- After doing an air-purge with a vacuum pump, the refrigerant pressure may not rise even if the stop valves are opened. This is because the refrigerant piping path is closed off by the outdoor unit electronic expansion valve, etc. There are no problems if the outdoor unit is run.

When recharging refrigerant, follow the procedure below.  
In case of recharge refrigerant (cause of refrigerant leak) please follow suggestion below (reference detail from service manual).

1. Turn on refrigerant recovery mode by the remote controller. Refer to "On site setting" in an installation manual attached to a remote controller.

Content of settings	Mode NO.	FIRST CODE NO.	SECOND CODE NO.	
Refrigerant recovery mode	16 (26)	7	01	03
			OFF	ON

2. Shut down the power at least 1 minute after setting process (1) is performed.
  - If the power is turned on before the process (3) - (6) are completed, the refrigerant recovery mode is turned off and the refrigerant cannot be recovered or charged normally. If the power is turned on by necessary, turn on Refrigerant recovery mode again.
3. Recover the refrigerant from both the refrigerant recovery port and liquid stop valve service port (or gas stop valve service port) simultaneously until the pressure drops below 0.09MPa (gauge pressure: -0.011MPa) by using a refrigerant recovery machine.
4. Modify the leakage points.
5. Perform the airtightness test and air-purge accordance with
  - **AIRTIGHTNESS TEST AND AIR-PURGE.**
6. Charge the refrigerant from the service port of the liquid side stop valve when recharging refrigerant.  
(Note) Do not turn on power during evacuation.  
The motor may be damaged due to vacuum discharge.

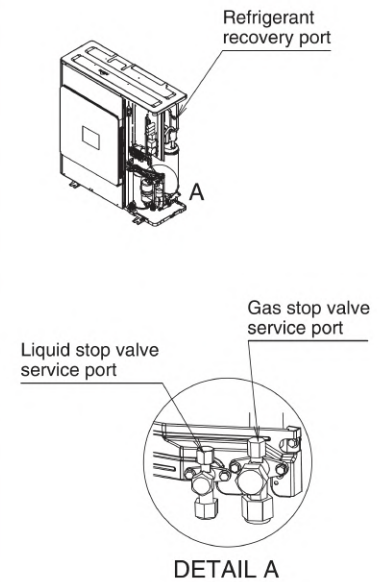

## 7 CHARGING REFRIGERANT (2/2)

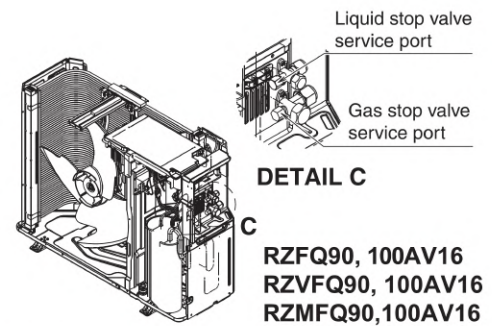
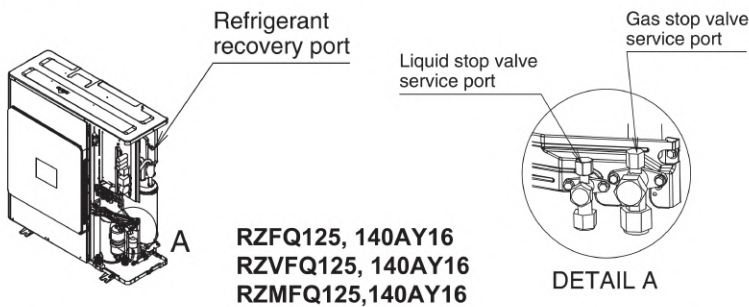

### Precautions when adding R32

- Before charging, check whether the cylinder has a siphon attached or not.

#### Charging a cylinder with an attached siphon

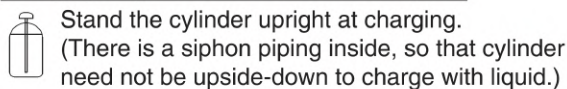

#### Charging other cylinders

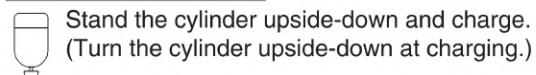

- To prevent entry of any impurities and insure sufficient pressure resistance, always use the special tools dedicated for R32.
- For models RZFQ90,100 & RZV/MFQ90,100, the refrigerant should be charged from the service port of the liquid side stop valve.

### ⚠ WARNING

To persons incharge of piping work

- Please be sure to open a stop valve after a refrigerant charging end (if it operates shut, a compressor will break down).
- After complete charging of refrigerant carry out refrigerant leak check and heat insulation work.
- Please do not emit a refrigerant into the atmosphere indiscriminately.

## 8 ELECTRICAL WIRING WORK (1/3)

### ⚠ WARNING

- Make sure to install a current balance type earth leakage breaker coping with high harmonics. (This unit is equipped with an inverter device. Use an earth leakage breaker coping with high harmonics to prevent wrong actuation.)

- Electrical wiring must be carried out by qualified personnel.
- Before obtaining access to terminal devices, all supply circuits must be interrupted.

## ⚠ CAUTION

### To the electrician

- Make sure to install a current balance type earth leakage breaker coping with high harmonics. (This unit is equipped with an inverter device. Use an earth leakage breaker coping with high harmonics to prevent wrong actuation.)
- Do not run the unit until the refrigerant charging is complete. (Operating the unit before the completion will break the compressor.)
- Do not remove the thermistors or sensors when the power supply and transmission wiring are connected. (Operating the unit with the thermistors and sensors removed will break the compressor.)
- Make certain that all electric wiring work is carried out by qualified personnel according to the applicable legislation and this installation manual, using a separate circuit. Insufficient capacity of the power supply circuit or improper electrical construction may lead to electric shocks or a fire.
- An insufficient power supply capacity or improper electric work may lead to electric shocks or a fire.
- The wiring between the indoor unit and outdoor unit must be for 230V.
- For electric wiring work, refer to also the " WIRING DIAGRAM ".
- When doing the electrical wiring, always shut off the power source before working, and do not turn on the branch switch until all work is complete.
- Make sure to earth the air conditioner. Earthing resistance should be according to applicable legislation.
- Do not connect the earth wiring to gas or water piping, lightning conductor or telephone earth wiring.
  - Gas piping.....Ignition or explosion may occur if the gas leaks.
  - Water piping.....Hard vinyl tubes are not effective earths.
  - Lightning conductor or telephone earth wiring.....Electric potential may rise abnormally if struck by a lightning bolt.
- The earth is needed in order to reduce the noise generated by the unit's inverter and influence on other appliances and to release the charged electric charge on the outdoor unit surface by leaked current.
- Do not install a phase advance capacitor for improvement of power factor. Since this unit is mounted with an inverter device, the effect of power factor improvement not only cannot be expected, but also there is a risk of the capacitor getting abnormally overheated due to harmonics.
- Be sure to use earth leakage breaker dedicated for earth leakage protection in combination with the load break switch with fuse or breaker for wiring.
- In case of three-phase. Machine, electric wiring must be connected in normal phase connection.
- For wiring, use the designated power supply wiring and connect firmly, then secure to prevent external force being exerted on the terminal attachment (power supply wiring, transmission wiring, earth wiring).
- Left-over wiring should not be wrapped and stuffed into the outdoor unit.
- To prevent the power wiring from being damaged by the knock hole edges, put it in a wiring piping or use insulated bush, etc. to protect it.
- To prevent the wiring from coming in contact with piping (particularly the high-pressure piping), secure it with the included clamping material as shown page 29.

## 8 ELECTRICAL WIRING WORK (2/3)

- When wiring, form the wiring so that the front plate does not float and make sure the front plate is securely fastened.
- Fix the power supply wiring, the earth wiring and the transmission wiring by clamps as shown in the figure.
- As shown in the following figure, please fix power supply wiring, field wiring and ground wire by clamp material.

**RZFQ90,100AV16**

**RZVFQ90,100AV16**

**RZMFQ90,100AV16**

- Carry out insulated processing of attaching an insulated sleeve.
- Power supply wiring, wiring between units and ground wire with tying as clamp as shown below.

⚠ Do not connect power supply to terminal block of transmission wiring. All system may get damaged.

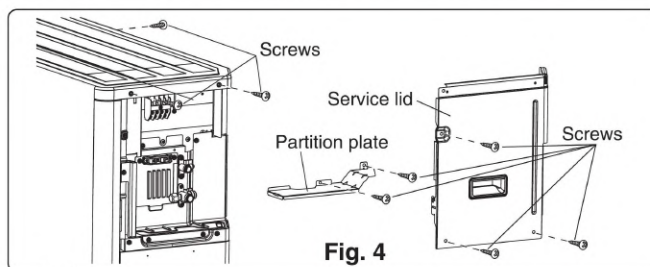

Fig. 4

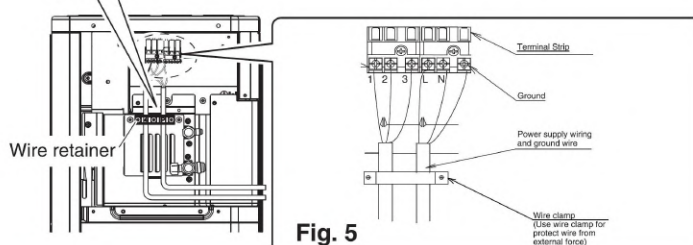
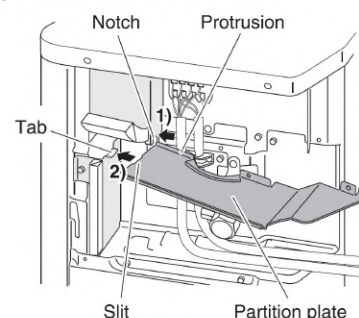

Fig. 5

### ■ How to attach the partition plate.

- 1) Insert the protrusion of the partition plate into the notch in the metal sheet.
- 2) Slide the partition plate so that the tab on the metal sheet fits into the slit on the partition plate.
- 3) Secure with 2 screws.



# ELECTRICAL WIRING WORK (3/3)

## Connection of wiring

### Precautions on wiring

- Use a round crimp-style terminal for connection to the power supply terminal board.  
In case it cannot be used due to unavoidable reasons, be sure to observe the following instruction.
- Do not connect wires of different gauge to the same power supply terminal.  
(Looseness in the connection may cause overheating.)

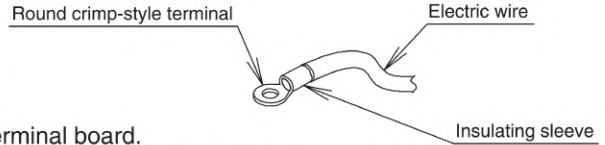

When connecting wires of the same gauge, connect them according to the below figure.

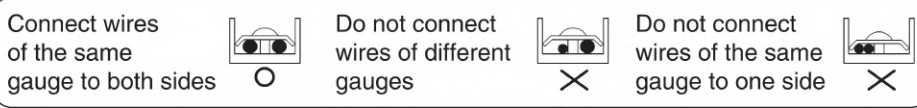

- Never use the stranded wiring which is soldered.  
(Slack in the electric wiring may cause abnormal heat.)
- Use the required wirings, connect them securely and fix these wirings so that external force may not apply to the terminals.
- Use a proper screw driver for tightening the terminal screws.  
If an improper screw driver is used, it may damage the screw head and a proper tightening cannot be carried out.
- If a terminal is over tightened, it may be damaged.  
Refer to the table on the right for tightening torque of terminals.

Tightening torque (N·m)	
M4 (Wire between units terminal board)	1.50±0.30
M4 (Power supply terminal board)	1.50±0.30
M4 (Ground wire between units)	1.69±0.25
M5 (Ground wire between units)	3.55±0.50

### Precautions on connecting terminal of grounding

- Ground wiring should be taken out from the cut out section of a cup washer.  
(Otherwise, contact of ground wiring is inadequate and it is ineffective.)

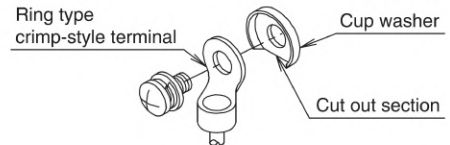

## WIRING OF POWER SUPPLY AND THE UNITS

For details on the wiring of the indoor unit and Transmission wiring refer to the installation manual of the indoor unit.

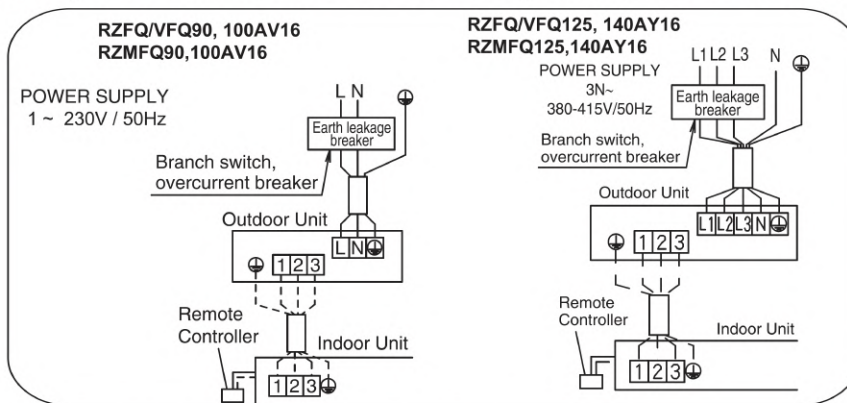

### SPECIFICATIONS OF STANDARD WIRING COMPONENTS

Outdoor Unit	Power supply		Wire type of Transmission
	Wire type (*)	Size	
RZFQ90, 100AV16 RZV/MFQ90, 100AV16 RZFQ125, 140AY16 RZV/MFQ125, 140AY16	H05VV-U5G	Wiring size and length must comply with local codes or [IEC 60335-1 (Table 11)]	H05VV-U4G2.5

(\*) Only in protected piping, use H07RN-F when protected pipes are not used.  
(Supply cords shall not be lighter than polychloroprene sheathed flexible cord (code designation 60245 IEC 57))

### NOTES

1. Select and install the power supply wiring in accordance with [IEC 60335-1 (Table 11)] or local laws and regulations.  
The maximum current of the outdoor and indoor units are shown on each name plate.
2. When installing wiring in a location that can easily come in contact with people, be sure to install an earth leakage breaker coping with high harmonics to prevent electric shock.
3. Breaker type and capacity shall be selected in accordance with local laws and regulations.

## CAUTION

### TO PERSONS INCHARGE OF ELECTRICAL WIRING WORK

- Do not operate the unit until the refrigerant charging is completed. (Running it before the piping is ready will break the compressor.)

RZFQ125,140AY16  
 RZVFQ125,140AY16  
 RZMFQ125,140AY16

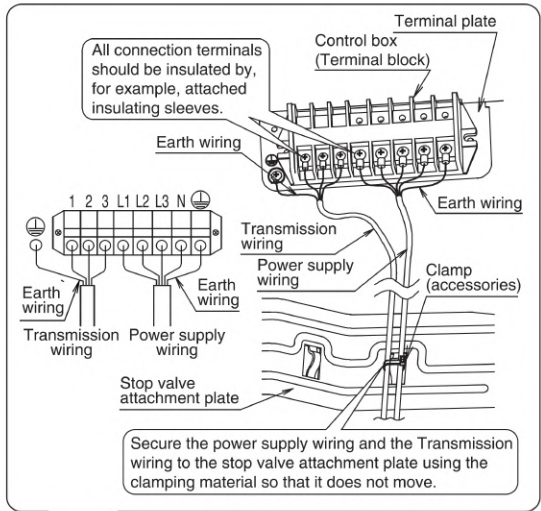
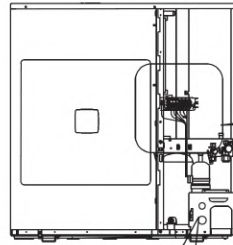

**Direction for pulling out the wiring**

- Plug the piping through-hole with putty or insulating material (field supply) so as not to leave any gap and prevent entry of small animals.
- Use the knock hole, on the front and side for the conduit (composite) operation.
- When punching knock hole remove pipe outlet from unit and open knock hole

When wiring, using single core wires for the earth wiring, tie the power supply wiring and the earth wiring by clamp material as shown in the right figure.

**CAUTION** Do not connect power supply to terminal block of transmission wiring. All system may get damaged.

## 9 CHECK ITEMS BEFORE TEST OPERATION

### PRE-RUN CHECKS

	ITEM TO CHECK	CHECK
Power supply wiring Transmission wiring Earth wiring	Is the wiring as mentioned on the wiring diagram? make sure no wiring has been forgotten and that there are no missing phases or reverse phases.	
	Does wiring between units put in and changed in continuation installation?	
	Is the unit properly grounded?	
	Are any of the wiring attachment screws loose?	
	Is the insulation resistance at least 1MΩ? • Use a 500V mega-tester when measuring insulation • ※ Do not use a mega-tester for circuits which except 220-240V.	
	Is an earth leakage circuit breaker used a current operated type which is compatible to the higher harmonic wave?	
	Does the earth leakage circuit breaker have appropriate rated current?	
Refrigerant piping	Is the size of the piping appropriate?	
	Is the insulation material for the piping attached securely? Are both the liquid and gas pipes insulated?	
	Are the stop valves for both the liquid side and the gas side open?	
Extra refrigerant	Did you write down the extra refrigerant and the refrigerant piping length?	
Indoor unit	Is the indoor unit fully installed? When the test run is started, the fan automatically begins turning.	

### WARNING

- When a power supply is switched on, when you leave from the outdoor unit, be sure to close the cover plate. (It becomes the cause of an electric shock).

## 10 TEST OPERATION

### ⚠ WARNING

- Never perform a test operation with the discharge piping thermistor (R2T) removed, as this might break the compressor.
- If the technician must leave the outdoor unit for some reason, switch places with another installation technician or close the plate. (It may cause electric shocks.)

### HOW TO TEST OPERATION

After the indoor and outdoor unit installation, be sure to perform the test operation in accordance with the following procedure.

1. Open the front plate and check that the liquid and gas sides of the stop valves are open.
  - <Be sure to close the front plate before the operation (there is a risk of electric shock)>
  - (Note) After doing an air-purge with a vacuum pump, the refrigerant pressure may not rise even if the stop valves are opened. This is because the refrigerant piping path is closed off by the outdoor unit electronic expansion valve, etc. There are no problems if the unit is run.
2. Attach the front plate to the outdoor unit and turn the power on at least 6 hours before operating the outdoor unit to protect the compressor.
3. Set to COOLING operation with the remote controller.
4. Perform the test operation.
5. Operate normally.
6. Confirm function of the indoor and outdoor units according to the operation manual.

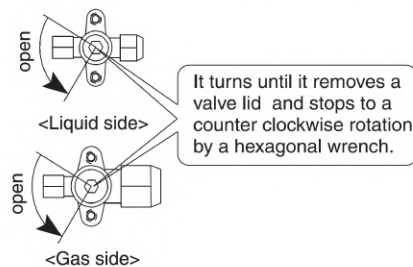

### MALFUNCTION DIAGNOSIS

- At the time of a test run, when the following malfunction code is displayed on remote control, the fault of installation construction can be considered.

Malfunction code	Installation error	Remedial action
[E3] [E5] [U0] [L8] [H6]	A failure of a stop valve to open	Open the stop valves.
[E3] [E5] [L4] [L8]	Closing of an air passage	Remove any obstacle to the airflow path.
[U1]	Missing phase, negative phase	Correct the wiring.
[U2]	Power supply unbalancing	Balance the power/Correct the wiring
[U4] [UF]	Incorrect connection of field wiring	Correct the wiring.
[UA]	Connection of incompatible indoor unit	Connect appropriate indoor unit (refer to the catalogue)
NO INDICATION	Mistake wiring or not connect wiring of power supply, indoor, outdoor, field wiring between indoor unit	To correct wiring or connect correctly

- When malfunction codes other than the above are displayed on remote control, considering that the failure of between an indoor and an outdoor unit may have. For the malfunction codes, please refer to the indoor unit's installation manual or outdoor service manual. (A malfunction code has what has a display according to the form of the interior of a room and an outdoor unit, and the thing which is not.)
- The followings can be considered causes when the breaker for power supply trips.
  - The capacity of a breaker for power supply is smaller than the required capacity of the leakage circuit breaker.
  - The leakage circuit breaker is not compatible to the higher harmonic wave.
- In case of already checking all equipment that not have any problem, but found air conditioner not cooling. Please re-check Motor operate valve coil not tighten or remove for 1<sup>st</sup> checking. If normally please re-confirm problem following service manual to solve problem.

### ⚠ CAUTION

#### To persons incharge of piping work and electric work

- Please check having attached the front board and the piping cover after a test run end when giving production over to customer.



---

**SPLIT SYSTEM****Air Conditioner**

---

**MODELS****(Ceiling-mounted Duct type)****FDMFQ50AV16****FDMFQ71AV16****FDMFQ90AV16****FDMFQ100AV16****FDMFQ125AV16****FDMFQ140AV16**

---

CAREFULLY READ THESE INSTRUCTIONS BEFORE INSTALLATION.  
KEEP THIS MANUAL IN A HANDY PLACE FOR FUTURE REFERENCE.

---





FDMFQ50AV16  
 FDMFQ71AV16  
 FDMFQ90AV16  
 FDMFQ100AV16

FDMFQ125AV16  
 FDMFQ140AV16

SPLIT SYSTEM  
 Air Conditioner

Installation manual

## CONTENTS

1. SAFETY PRECAUTIONS .....	35
2. BEFORE INSTALLATION .....	36
3. SELECTION OF INSTALLATION LOCATION.....	38
4. PREPARATION BEFORE INSTALLATION .....	39
5. INSTALLATION OF INDOOR UNIT .....	40
6. REFRIGERANT PIPING WORK.....	41
7. DRAIN PIPING WORK .....	42
8. DUCT WORK.....	45
9. ELECTRIC WIRING WORK.....	45
10. FIELD SETTING .....	48
11. TEST OPERATION.....	49
12. MALFUNCTION CODE.....	50
13. CAUTION.....	53
14. HOW TO RE-USE THE EXISTING PIPING.....	57

### Important information regarding the refrigerant used

This product contains fluorinated greenhouse gases covered by the Kyoto Protocol. Do not vent gases into the atmosphere.

Refrigerant type: R32



GWP<sup>(1)</sup> value: 675\*

<sup>(1)</sup>GWP = global warming potential

The refrigerant quantity is indicated on the unit name plate.

\*This value is based on F gas regulation (842/ 2006).

## 1. SAFETY PRECAUTIONS

	<b>Read the precautions in this manual carefully before operating the unit.</b>
	<b>This appliance is filled with R32.</b>

Please read these "SAFETY CONSIDERATIONS" carefully before installing air conditioning unit and be sure to install it correctly. After completing the installation, make sure that the unit operates properly during the start-up operation.

Please instruct the customer on how to operate the unit and keep it maintained.

Also, inform customers that they should store this installation manual along with the operation manual for future reference.

**This air conditioner comes under the term "appliances not accessible to the general public".**

This is a class A product. In a domestic environment this product may cause radio interference in which case the user may be required to take adequate measures.

- This manual classifies the precautions into WARNINGS and CAUTIONS.

Be sure to follow all the precautions below: They are all important for ensuring safety.

 **WARNING** .....Indicates a potentially hazardous situation which, if not avoided, could result in death or serious injury.

 **CAUTION** .....Indicates a potentially hazardous situation which, if not avoided, may result in minor or moderate injury. It may also be used to alert against unsafe practices.

- After the installation is completed, test the air conditioner and check if the air conditioner operates properly. Give the user adequate instructions concerning the use and cleaning of the indoor unit according to the Operation Manual. Ask the user to keep this manual in a handy place for future reference.

### WARNING

- Do not use means to accelerate the defrosting process or to clean, other than those recommended by the manufacturer.
- The appliance must be stored in a room without continuously operating ignition sources (for example: open flames, an operating gas appliance or an operating electric heater).
- Do not pierce or burn.
- Be aware that refrigerants may not contain an odour.
- Floor area required for installation of the equipment, refer to the installation manual of the outdoor unit.
- Comply with national gas regulations.
- Ask your local dealer or qualified personnel to carry out installation work. Improper installation may result in water leakage, electric shocks or a fire.
- Perform installation work in accordance with this installation manual. Improper installation may result in water leakage, electric shocks or a fire.
- Consult your local dealer regarding what to do in case of refrigerant leakage. When the air conditioner is installed in a small room, it is necessary to take proper measures so that the amount of any leaked refrigerant does not exceed the concentration limit in the event of a leakage. Otherwise, this may lead to an accident due to oxygen deficiency.
- Be sure to use only the specified parts and accessories for installation work. Failure to use the specified parts may result in the air conditioner falling down, water leakage, electric shocks, a fire, etc.
- Install the air conditioner on a foundation that can withstand its mass. Insufficient strength may result in the air conditioner falling down and causing injury. In addition, it may lead to vibration of indoor units and cause unpleasant chattering noise.
- Carry out the specified installation work in consideration of strong winds, typhoons, or earthquakes. Improper installation may result in an accident such as air conditioner falling.
- Make certain that all electrical work is carried out by qualified personnel according to the applicable legislation (Note 1) and this installation manual, using a separate circuit. In addition, even if the wiring is short, make sure to use a wiring that has sufficient length and never connect additional wiring to make the length sufficient. Insufficient capacity of the power supply circuit or improper electrical construction may lead to electric shocks or a fire. (Note 1) applicable legislation means "All international, national and local directives, laws, regulations and/or codes which are relevant and applicable for a certain product or domain".

- Earth the air conditioner.  
Do not connect the earth wiring to gas or water piping, lightning conductor or telephone earth wiring.  
Incomplete earthing may cause electric shocks or a fire.
- Be sure to install an earth leakage breaker.  
Failure to do so may cause electric shocks and a fire.
- Disconnect the power supply before touching the electric components.  
If you touch the live part, you may get electric shocks.
- Make sure that all wiring is secure, using the specified wirings and ensuring that external forces do not act on the terminal connections or wirings.  
Incomplete connection or fixing may cause an overheat or a fire.
- When wiring between the indoor and outdoor units, and wiring the power supply, form the wirings orderly so that the control box lid can be securely fastened.  
If the control box lid is not in place, overheating of the terminals, electric shocks or a fire may be caused.
- If refrigerant gas leaks during installation work, ventilate the area immediately.  
Toxic gas may be produced if refrigerant gas comes into contact with a fire.
- After completing the installation work, check to make sure that there is no leakage of refrigerant gas.  
Toxic gas may be produced if refrigerant gas leaks into the room and comes into contact with a source of a fire, such as a fan heater, stove or cooker.
- Never directly touch any accidental leaking refrigerant. This could result in severe wounds caused by frostbite.
- When installing or relocating the air conditioner, be sure to bleed the refrigerant circuit to ensure it is free of air, and use only the specified refrigerant (R32).  
The presence of air or other foreign matter in the refrigerant circuit causes abnormal pressure rise, which may result in equipment damage and even injury.
- Do not allow children to climb on the outdoor unit and avoid placing objects on the unit.  
Injury may result if the unit becomes loose and falls.
- When flared joints are reused indoors, the flare part shall be re-fabricated.

---

### CAUTION

- Install drain piping according to this installation manual to ensure good drainage, and insulate the piping to prevent condensation.  
Improper drain piping may cause water leakage, make the furniture get wet.
- Install the air conditioner, power supply wiring, remote controller wiring and transmission wiring at least 1 meter away from televisions or radios to prevent image interference or noise.  
(Depending on the radio waves, a distance of 1 meter may not be sufficient to eliminate the noise.)
- Install the indoor unit as far as possible from fluorescent lamps.  
If a wireless remote controller kit is installed, the transmission distance may be shorter in a room where an electronic lighting type (inverter or rapid start type) fluorescent lamp is installed.
- Do not install the air conditioner in places such as the following:
  1. Where there is mist of oil, oil spray or vapour for example a kitchen.  
Resin parts may deteriorate, and fall out or water may leak.
  2. Where corrosive gas, such as sulfurous acid gas, is produced.  
Corrosion of copper pipings or brazed parts may cause the refrigerant to leak.

3. Where there is machinery which emits electromagnetic waves.  
Electromagnetic waves may disturb the control system, and cause malfunction of the equipment.
  4. Where flammable gases may leak, where carbon fibre or ignitable dust is suspended in the air or where volatile flammables, such as thinner or gasoline, are handled.  
If the gas should leak and remain around the air conditioner, it may cause ignition.
- The air conditioner is not intended for use in a potentially explosive atmosphere.
  - Pay careful attention when transporting the product.  
Carry the product by the handle sections indicated on the packaging material.  
Do not hold the PP band since the PP band can become loose and may result in danger.
  - Do not touch the heat exchanger fins.  
Inadvertently touching the fins can cause injury.
  - Make sure to provide for adequate measures in order to prevent that the outdoor unit be used as a shelter by small animals.  
Small animals making contact with electrical parts can cause malfunctions, smoke or fire. Please instruct the customer to keep the area around the unit clean.
  - Install in a machine room that is free of moisture.  
The unit is designed for indoor use.
  - The refrigerant R32 requires that strict precautions be observed for keeping the system clean, dry and tightly sealed.
    - Clean and dry  
Strict measures must be taken to keep impurities (including SUNISO oil and other mineral oils as well as moisture) out of the system.
    - Tightly sealed  
R32 contains no chlorine, does not destroy the ozone layer and so does not reduce the earth's protection against harmful ultraviolet radiation.  
R32 will contribute only slightly to the greenhouse effect if released into the atmosphere.
  - Only qualified personnel can handle, fill, purge and dispose of the refrigerant.
  - Disposal requirements
    - Dismantling of the unit, treatment of the refrigerant, of oil and of other parts must be done in accordance with relevant local and national legislation.
- 

## 2. BEFORE INSTALLATION

**When unpacking the indoor unit or moving the unit after unpacked, hold the hangers (4 places) and do not apply force to other parts (particularly refrigerant piping, drain piping).**

- Make sure to check in advance that the refrigerant to be used for installation work is R32.  
(The air conditioner will not properly operate if a wrong refrigerant is used.)
- For installation of the outdoor unit, refer to the installation manual attached to the outdoor unit.
- Do not throw away the accessories until the installation work is completed.
- After the indoor unit is carried into the room, to avoid the indoor unit from getting damaged, take measures to protect the indoor unit with packing materials.

- (1) Determine the route to carry the unit into the room.
- (2) Do not unpack the unit until it is carried to the installation location.











Where unpacking is unavoidable, use a sling of soft material or protective plates together with a rope when lifting, to avoid damage or scratches to the indoor unit.

- Have the customer actually operate the air conditioner while looking at the operation manual.  
Instruct the customer how to operate the air conditioner (particularly cleaning of the air filters, operation procedures, and temperature adjustment).
- Have the customer actually operate the air conditioner while looking at the operation manual.  
Instruct the customer how to operate the air conditioner (particularly cleaning of the air filters, operation procedures, and temperature adjustment).
- Do not use the air conditioner in a salty atmosphere such as coastal areas, vehicles, vessels or where voltage fluctuation is frequent such as factories.
- Take off static electricity from the body when carrying out wiring and the control box lid is removed.  
The electric parts may be damaged.

## 2-1 ACCESSORIES

Check if the following accessories are attached to the indoor unit.

Table 1

Name	-	Insulation for fitting	Sealing pad	-	-	-
Quantity	1 each	1 each	-	-	-	-
Shape	 Metal clamp (1)	 Thin for liquid pipe (3)	 1 pc. Large (Dark grey) (5)	 9 Pc. Clamp (7)	 2 Pc. Wire sealing material (9)	 2 Pc. Wire fixing screw (11)
	 Drain Hose(2)	 Thick for gas pipe (4)	 2 pc. Middle (Dark grey) (6)	 4 Pc. Washer fixing plate (8)	 2 Pc. Wire fixing bracket (10)	

## 2-2 OPTIONAL ACCESSORIES

- A remote controller is required for the indoor unit.
- There are 2 kinds of remote controller; wired type and wireless type.

Install the remote controller to the place where the customer has given consent.

Refer to the catalog for the applicable model.

(Refer to the installation manual attached to the remote controller for how to install.)

## CARRY OUT THE WORK GIVING CAUTION TO THE FOLLOWING ITEMS AND AFTER THE WORK IS COMPLETED CHECK THESE AGAIN.

### 1. Items to be checked after the installation work is completed

Items to be checked	In case of defective	Check column
Are the indoor and outdoor units rigidly fixed?	Drop · vibration · noise	
Are the installation works of the outdoor and indoor units completed?	Does not operate · burnout	
Have you carried out a leakage test with the test pressure specified in the outdoor unit installation manual?	Does not cool.	
Is the insulation of refrigerant piping and drain piping completely carried out?	Water leakage	
Does the drain flow out smoothly?	Water leakage	
Is the power supply voltage identical to that stated in the manufacturer's label on the air conditioner?	Does not operate · burnout	
Are you sure that there is no wrong wiring or piping or no loose wiring?	Does not operate · burnout	
Is earthing completed?	Danger in case of leakage	
Are the sizes of electric wiring according to the specification?	Does not operate · burnout	
Are any of air outlets or inlets of the indoor and outdoor units blocked with obstacles? (It may lead to capacity drop due to fan speed drop or malfunction of equipment.)	Does not cool	
Is the external static pressure set correctly?	Does not cool	
Have you recorded the refrigerant piping length and the refrigerant charge amount added?	Refrigerant charge amount is not clear	

Make sure to recheck the items of "SAFETY PRECAUTIONS".

## 2. Items to be checked at delivery

Items to be checked	Check column
Have you carried out field setting? (if necessary)	
Are the control box lid, the air filter and the suction grille attached?	
Does the cool air discharge during the cooling operation? Does the indoor unit makes unpleasant sound of air discharge?	
Have you explained how to operate the air conditioner showing the operation manual to the customer?	
Have you explained the description of cooling, program dry and automatic (cooling) given in the operation manual to the customer?	
If you set the fan speed at thermostat OFF, did you explain the set fan speed to the customer.	
Have you handed the operation manual and the installation manual to the customer?	
Have you checked that there is no generation of abnormal noise (i.e., noise resulting from contamination or missing parts)?	
Is the printed circuit board switch not on the emergency (EMG.) side? The switch is factory set to the normal (NORM.) side.	
If an optional accessory is in use, did you check the operation of the optional accessory and make field settings as needed?	
Have you explained failure examples of <b>3. SELECTION OF INSTALLATION LOCATION?</b>	

### Points of the operation explanation

In addition to the general usage, since the items in the operation manual with the **⚠ WARNING** and **⚠ CAUTION** marks are likely to result in human bodily injuries and property damages, it is necessary not only to explain these items to the customer but also to have the customer read them. Furthermore, it is necessary to have the customer read through the troubleshooting items while explaining the above items.

## 3. SELECTION OF INSTALLATION LOCATION

Hold the hangers at 4 locations to move the indoor unit when unpacking or after unpacked, and do not apply force to the piping (refrigerant and drain) and air outlet flange. If the temperature and humidity in the ceiling is likely to exceed 30°C, RH80%, use the additional insulation stick to the indoor unit.

Use the insulation such as glass wool or polyethylene that has thickness of 10 mm or more. However, keep the insulated outside dimension smaller than the ceiling opening so that the unit may go through the opening at installation.

### (1) Select the installation location that meets the following conditions and get approval of the customer.

- Where the cool and warm air spreads evenly in the room.
- Where there are no obstacles in the air passage.
- Where drainage can be ensured.
- Where the ceiling's lower surface is not remarkably inclined.
- Where there is sufficient strength to withstand the mass of the indoor unit. (If the strength is insufficient, the indoor unit may vibrate and get in contact with the ceiling and generate unpleasant chattering noise.)
- Where a space sufficient for installation and service can be ensured.
- Where the piping length between the indoor and the outdoor units is ensured within the allowable length. (Refer to the installation manual attached to the outdoor unit.)
- Where there is no risk of flammable gas leak.

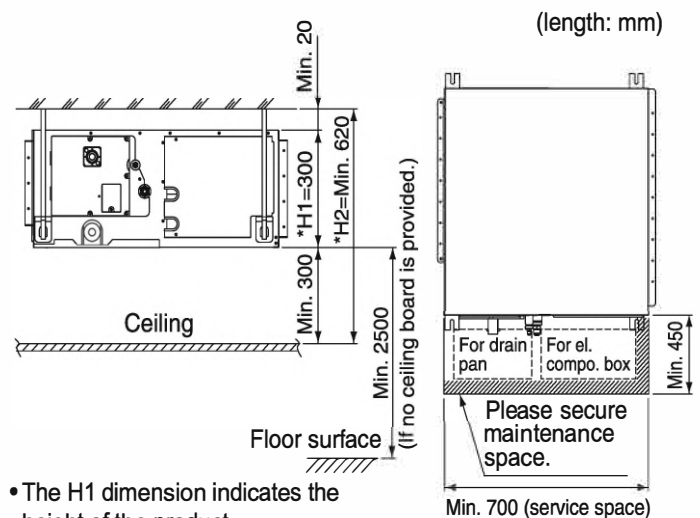

- The H1 dimension indicates the height of the product.
- Determine the H2 dimension by maintaining a downward slope of at least 1/100 as specified in "7. DRAIN PIPING WORK".

[Required installation place]  
The dimensions indicate the minimum required space of installation.

Fig. 1

**<Failure example>**

If there is an obstacle in the airflow path or proper installation space is not provided, the indoor unit will cause air volume reduction and take in air blown out of the indoor unit, thus resulting in performance degradation or turning the thermostat OFF frequently.

**CAUTION**

- Install the indoor and outdoor units, power supply wiring, remote controller wiring and transmission wiring at least 1 meter away from televisions or radios to prevent image interference or noise. (Depending on the radio waves, a distance of 1 meter may not be sufficient to eliminate the noise.)
- Install the indoor unit as far as possible from fluorescent lamps. If a wireless remote controller kit is installed, the transmission distance may be shorter in a room where an electronic lighting type (inverter or rapid start type) fluorescent lamp is installed.

**(2) Use hanging bolts for installation.**

Investigate if the installation place can withstand the mass of the indoor unit and, if necessary, hang the indoor unit with bolts after it is reinforced by beams etc.

**4. PREPARATION BEFORE INSTALLATION**

**(1) Check the relation of location between the ceiling opening and the indoor unit hanging bolts.**

- Provide one of the following service spaces for the maintenance and inspection of the control box and drain pump or for other services.
  1. Inspection hatch 1 and 2 (450 × 450) for the el. compo box and a minimum space of 300 mm at the bottom of the product. (Refer Fig. 2-1)
  2. Inspection hatch 1 (450 × 450) on the control box side and inspection hatch 2 on the bottom of the product.(Fig. 2-3, arrow A-1)
  3. Inspection hatch 3 on the bottom of the product and on the bottom side of the control box, see direction view A-2 (Refer Fig. 2-3)

**Case 1**

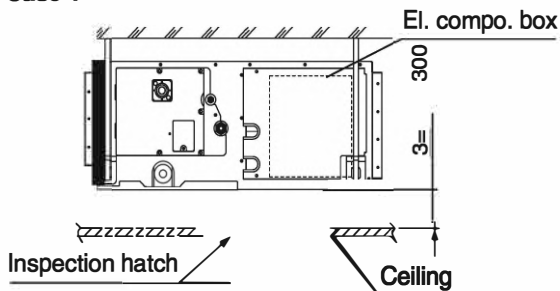

**Fig.2-1**

• 50-71 type

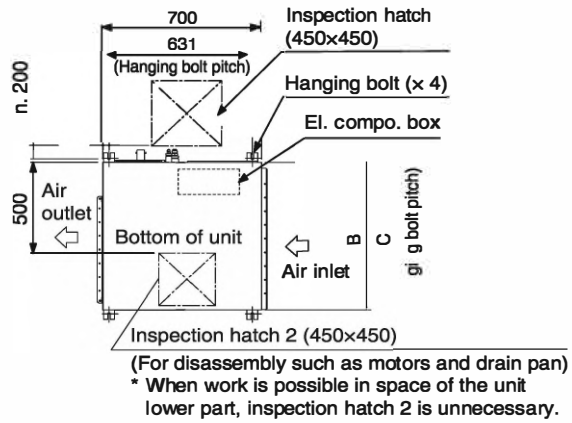

**Fig.2-2**

**Case 2, 3**

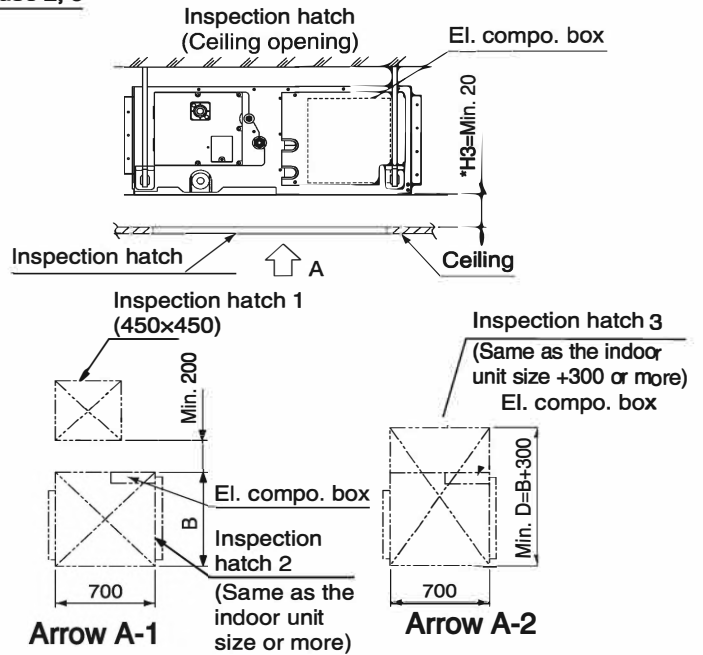

**Fig.2-3**

Model	B	C	D
50.71	1000	1038	1300
90.100.125.140	1400	1438	1700

(All dimensions are in mm)

- (2) Mount canvas ducts to the air outlet and inlet so that the vibration of the indoor unit will not be transmitted to the ducts or ceiling. Furthermore, attach sound absorbing material (thermal insulation material) to the duct inner walls and anti-vibration rubber to the hanging bolts (refer to 8. DUCT WORK).
- (3) The indoor unit is set to standard external static pressure.
  - If external static pressure is higher or lower than the standard set value, the remote controller may be used to make on-site setting change in the external static pressure. Refer to 10. FIELD SETTING.

#### (4) Open installation holes

(in the case of installation onto the existing ceiling).

- Open the installation holes on the ceiling of the installation location, and work on the refrigerant piping, drain piping, remote controller wiring (unless a wireless remote controller is used), and wiring between the indoor and outdoor units to the piping connection port and wiring connection port of the indoor unit (refer to each piping and wiring procedure items).
- Ceiling framework reinforcement may be required in order to keep the ceiling horizontal and prevent ceiling vibration after opening the ceiling holes. For details, consult your building and upholstery work contractors.

#### (5) Install the hanging bolts.

- Use M10 bolts for hanging the indoor unit. Use hole-in-anchors for the existing bolts and embedded inserts or foundation bolts for new bolts, and fix the indoor unit firmly to the building so that it may withstand the mass of the unit. In addition, adjust clearance (50 - 100 mm) from the ceiling in advance.

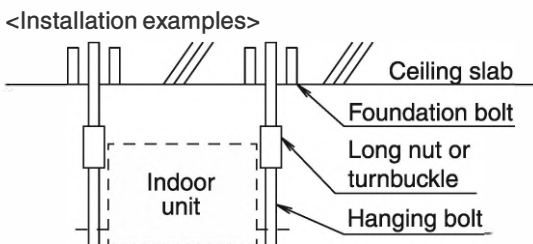

Note) Components shown in the figure above are all local procurement.

Fig. 3

### CAUTION

- Secure a sufficient maintenance space for the drain pan and electrical components before installing the indoor unit.
- Secure a sufficient maintenance space for the filter chamber, and peripheral components before installing the indoor unit.

## 5. INSTALLATION OF INDOOR UNIT

Depending on the optional parts, it may be easier to attach them before installing the indoor unit. Refer to also the installation manual attached to the optional parts.

For installation, use the attached installation parts and specified parts.

(1) Install the indoor unit temporarily.

- Connect the hanging brackets to the hanging bolts. Be sure to use and tighten the nut and washer (procured in the field) for each hanging bracket from both upper and lower sides of the hanging bracket. (Refer to the fig. 4) At that time, the fall of the washer for the hanging bracket can be prevented if the washer fixing plate (8) is used.

#### [Fixing hanging brackets]

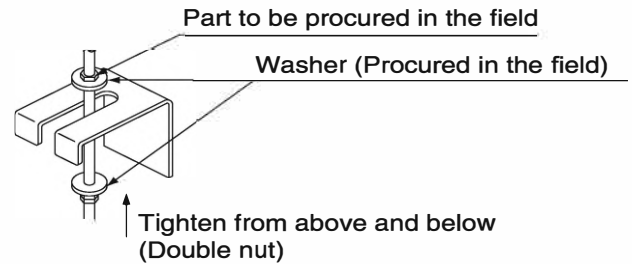

#### [Fixing method of washers]

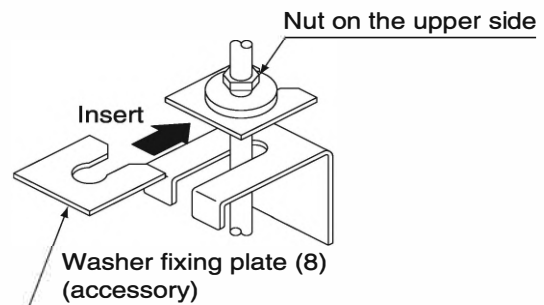

Fig. 4

- Keep the air outlet covered with a protective sheet to prevent weld spatter and other foreign materials from entering the indoor unit and damaging the resin drain pan. (If holes or cracks are generated in the resin drain pan, water can leak.)

(2) Adjust so that the unit is properly positioned.

(3) Check the level of the unit. (Refer to Fig. 5)

(4) Remove the washer fixing plate used for preventing the washer for hanger from dropping and tighten the upper side nut.

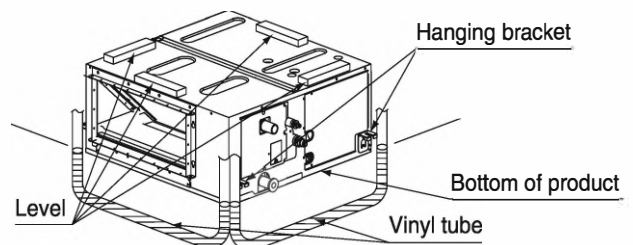

Feed water into the tube and set the indoor unit to the water levels on the left and right.

[Maintaining horizontality]

Fig. 5



**CAUTION**

- **Install the indoor unit leveled.**  
If the indoor unit is inclined and the drain piping side gets high, it may cause malfunction of float switch and result in water leakage.
- **Attach nuts on the upper and lower side of hanger.**  
If there is no upper nut and the lower nut is over-tightened, the hanger and the top plate will deform and cause abnormal sound.
- **Do not insert materials other than that specified into the clearance between the hanger and the washer for hanger.**  
Unless the washers are properly attached, the hanging bolts may come off from the hanger.

**WARNING**

**The indoor unit must be securely installed on a place that can withstand the mass.**  
If the strength is insufficient, the indoor unit may fall down and cause injuries.

**6. REFRIGERANT PIPING WORK**

- For the outdoor unit refrigerant piping, refer to the installation manual attached to the outdoor unit.
- Carry out insulation of both gas and liquid refrigerant piping securely. If not insulated, it may cause water leakage. For gas piping, use insulation material of which heat resistant temperature is not less than 120°C.  
For use under high humidity, strengthen the insulation material for refrigerant piping. If not strengthened, the surface of insulation material may sweat.
- Before installation work, make sure that the refrigerant is R32. (Unless the refrigerant is R32, the normal operation cannot be expected.)

**WARNING**

**When flared joints are reused indoors, the flare part shall be re-fabricated.**

**CAUTION**

**This air conditioner is a dedicated model for new refrigerant R32. Make sure to meet the requirements shown below and carry out installation work.**

- **Use dedicated piping cutters and flaring tools for R32.**
- **When making a flare connection, coat the flared inner surface only with ether oil or ester oil.**
- **Use only the flare nuts attached to the air conditioner. If other flare nuts are used, it may cause refrigerant leakage.**
- **To prevent contamination or moisture from getting into the piping, take measures such as pinching or taping the pipings.**

**Do not mix substance other than the specified refrigerant such as air into the refrigeration circuit. If the refrigerant leaks during the work, ventilate the room.**

- The refrigerant is pre-charged in the outdoor unit.
- When connecting the pipings to the air conditioner, make sure to use a spanner and a torque wrench as shown in Fig. 6.
- For the dimension of flared part and the tightening torque, refer to the Table 2.
- When making a flare connection, coat the flared inner surface only with ether oil or ester oil. (Refer to Fig. 7)  
Then, turn the flare nut 3 to 4 times with your hand and screw in the nut.

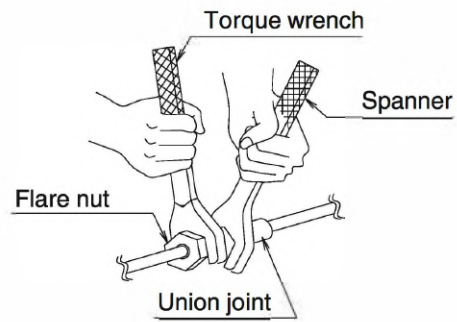

Fig.6

Coat the flared inner surface only with ether oil or ester oil

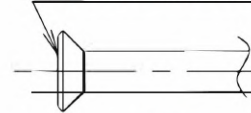

Fig. 7

Table 2

Piping size (mm)	Tightening torque (N·m)	Dimension for processing flare A (mm)	Flare shape
φ6.35	15.7± 1.5	9 ± 0.2	
φ9.5	36.3± 3.6	13.0± 0.2	
φ12.7	54.9± 5.4	16.2± 0.2	
φ15.88	68.9 ±6.8	19.5± 0.2	

**CAUTION**

**Do not have oil adhere to the screw fixing part of resin parts.**

If oil adheres, it may weaken the strength of screwed part.

**Do not tighten flare nuts too tight.**

If a flare nut cracks, the refrigerant may leak.

- If there is no torque wrench, use Table 3 as a rule of thumb.  
When tightening a flare nut with a spanner harder and harder, there is a point where the tightening torque suddenly increases.  
From that position, tighten the nut additionally at the angle shown in Table 3.  
After the work is finished, check securely that there is no gas leak.  
If the nut is not tightened as instructed, it may cause slow refrigerant leak and result in malfunction (such as does not cool or heat).

Table 3

Piping size (mm)	Tightening angle	Recommended arm length of tool used
φ6.35	60° - 90°	approx. 200 mm
φ9.5	60° - 90°	approx. 200 mm
φ12.7	30° - 60°	approx. 300 mm
φ15.88	30° - 60°	approx. 308 mm

**CAUTION**

**Insulation of field piping must be carried out up to the connection inside the casing.**

If the piping is exposed to the atmosphere, it may cause sweating, burn due to touching the piping, electric shocks or a fire due to the wiring touching the piping.

On completion of installation work, check that there is no gas leakage. Refer to the illustrations on the right hand side and be sure to perform heat insulation work on the piping joints after gas leakage. (Refer Fig.8)

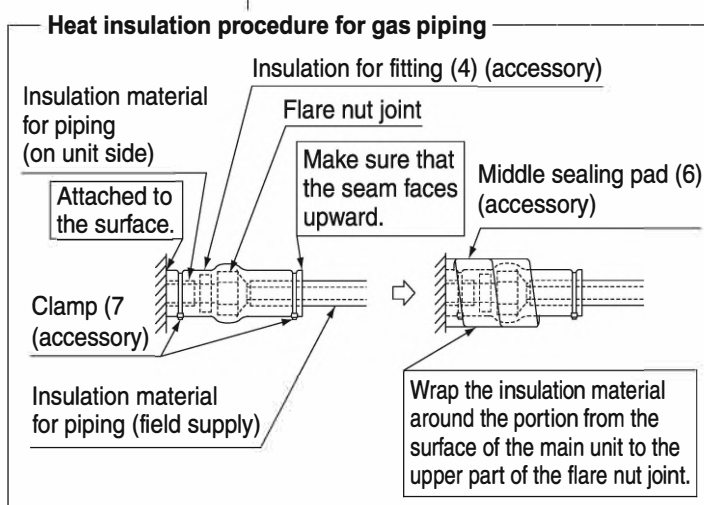
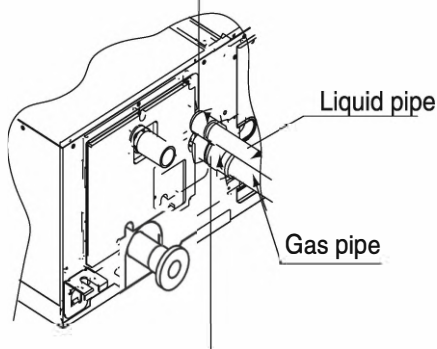
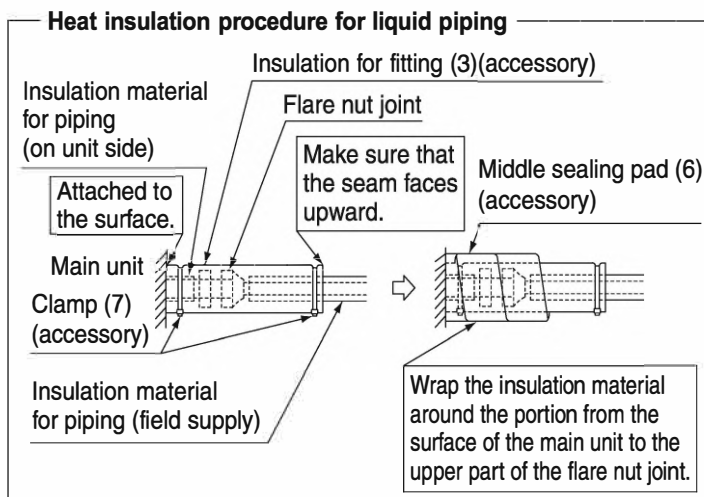

Fig. 8

- Use the insulation for fitting (3) and (4) provided to the liquid piping and gas piping, respectively and conduct heat insulation work. (Tighten both edges of the insulation for fitting (3) and (4) for each joint with clamp (7).)
- Make sure that the joint of the insulation for fitting (4) and (5) for the joint on the liquid piping and gas piping side faces upwards.
- Wrap the middle sealing material (6) around the insulation for fitting (3) and (4) for the joint (flare nut part).

- Before brazing refrigerant piping, have nitrogen flow through the refrigerant piping and substitute air with nitrogen (NOTE 1) (Refer to Fig. 9). Then, carry out brazing (NOTE 2).

After all the brazing works are finished, carry out flare connection with the indoor unit. (Refer to Fig. 8)

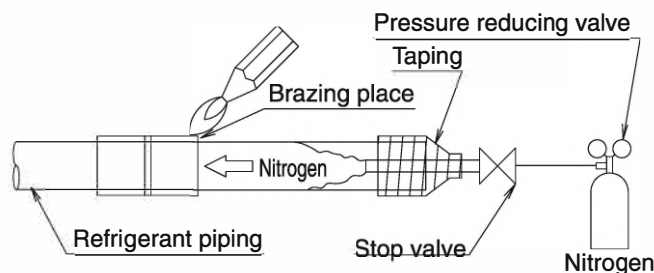

Fig. 9

#### NOTE

1. The proper pressure for having nitrogen flow through the piping is approximately 0.02 MPa, a pressure that makes one feel like slight breeze and can be obtained through a pressure reducing valve.

2. Do not use flux when brazing refrigerant piping. Use phosphor copper brazing filler metal (BCuP-2: JIS Z 3264/B-Cu93P-710/795: ISO 3677) that does not require flux.

(If chlorinated flux is used, the piping will be corroded and, in addition if fluorine is contained, the refrigerant oil will be deteriorated and the refrigerant circuit will be affected badly.)

3. When carrying out leakage test of refrigerant piping and the indoor unit after the installation of indoor unit is finished, confirm the connecting outdoor unit installation manual for test pressure.

Refer to also the outdoor unit installation manual or technical document for refrigerant piping.

4. In case of refrigerant shortage due to forgetting additional refrigerant charge etc., it will result in malfunction such as does not cool.

Refer to the outdoor unit installation manual or technical document for refrigerant piping.

#### CAUTION

**Do not use antioxidant when brazing piping.**

It may result in malfunction of components and clogging of piping due to residue.

## 7. DRAIN PIPING WORK

### (1) Carry out drain piping.

Carry out drain piping so that drainage is ensured.

- Select the piping diameter equal to or larger than (except for riser) that of the connection piping (polyvinyl chloride piping, nominal diameter 25 mm, outside diameter 32 mm).
- Install the drain piping as short as possible with downward inclination of 1/100 or more and without such that air may not stagnate. (Refer to Fig.10)

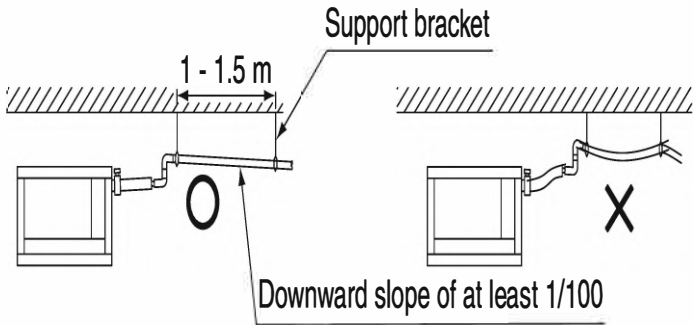

Fig. 10

**CAUTION**

If drain stagnates in the drain piping, the piping may be clogged.

- If sufficient downward inclination cannot be ensured, carry out upward drain piping.
- Install supports at a distance of 1 to 1.5 m so that the piping may not deflect (Refer Fig. 10)
- Make sure to use the attached drain hose (2) and the metal clamp (1).

Insert the drain hose (2) into the drain socket up to the point where the socket diameter becomes larger. Put the metal clamp (1) to the taped hose end. Be sure to fasten the screw of the metal clamp (1) until the margin of the screw thread decreases to 4 mm or less.

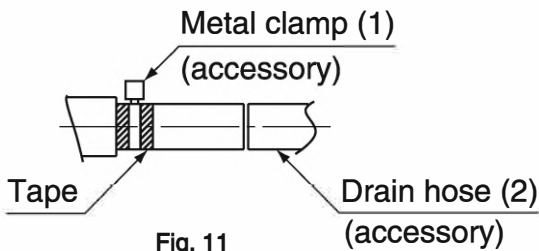

Fig. 11

**CAUTION**

- Tighten the metal clamp (1) on specified above otherwise. The drain hose (2), the socket or the metal clamp (1) may be damaged.

- Wrap the vinyl tape around the end of the metal clamp (1) so that the sealing material (Large) (5) to be used at the next process may not be damaged with the clamp end or bend the tip of the metal clamp (1) inward as shown. (Refer to Fig. 12)

**<In case of sticking vinyl tape>**

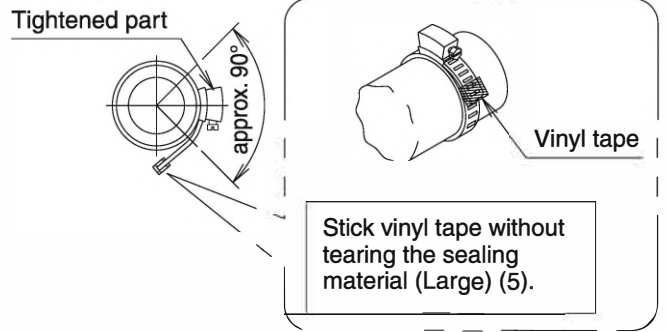

**<In case of bending the tip>**

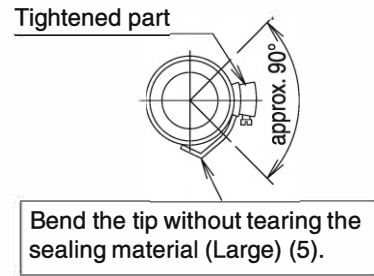

Fig. 12

**< Caution to be taken when carrying out upward drain piping (Refer to Fig. 13) >**

- The maximum height of the drain riser is 467 mm. Since the drain pump mounted on this indoor unit is a high head type, from the characteristic point of view, the higher the drain riser the lower the draining noise. Therefore, the drain riser of 300 mm or higher is recommended.
- For upward drain piping, keep the horizontal piping distance of 300 mm or less between the drain socket root to the drain riser.

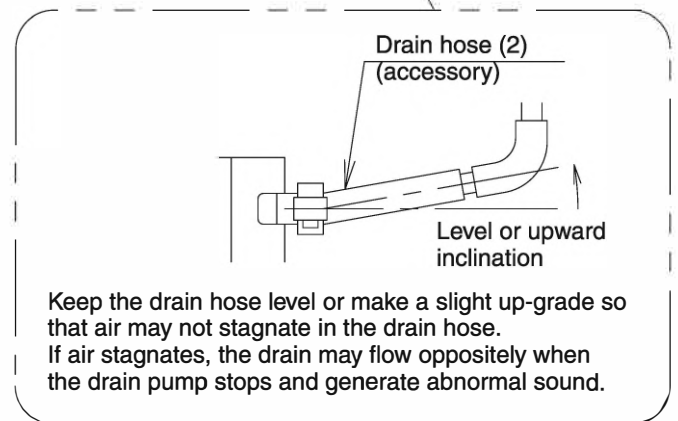
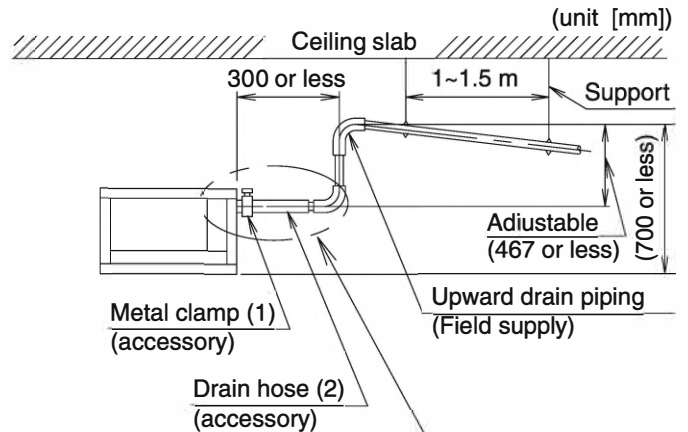

Fig. 13

**CAUTION**

- To avoid the attached drain hose (2) getting excessive force, do not bend nor twist it. It may cause water leakage.
- As for drain piping connection, do not connect the drain hose directly to a sewage that gives off ammonia odor. (The ammonia in the sewage may go through the drain piping and corrode the heat exchanger of the indoor unit.)
- In case of centralized drain piping, carry out piping work according to the procedure shown in the following Fig. 14.

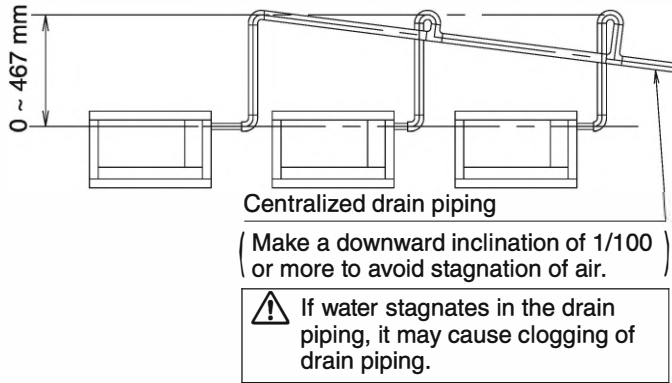

Fig. 14

- As for the size of centralized drain piping, select the size that meets the capacity of indoor units to be connected. (Refer to the technical document)
- Positioning the upward drain piping at an angle may cause float switch malfunction and lead to water leakage.
- While replacing with new indoor unit, use the attached new drain hose (2) and the metal clamp (1). If an old drain hose or a metal clamp is used, it may cause water leakage.

**(2) After piping is finished, check if the drain flows smoothly.**

**[When the electric wiring work is finished]**

- Gradually pour 1 liter of water from the inspection port at the bottom of the drain socket on the left side of the drain socket into the drain pan giving caution to avoid splashing water on the electric components such as drain pump and confirm drainage by operating the indoor unit under cooling mode according to 10. FIELD SETTING. (Refer to Fig. 15)

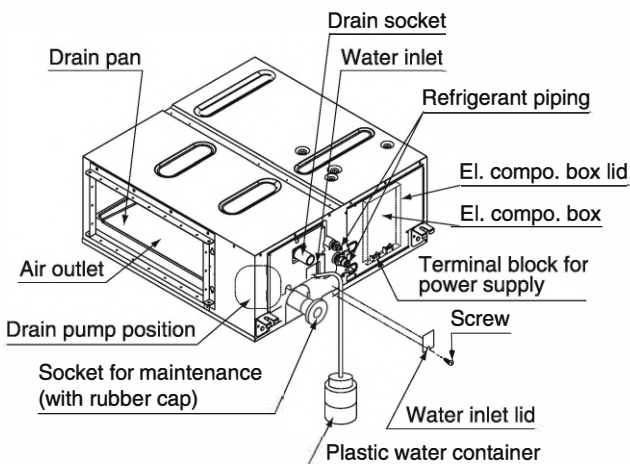

Fig. 15

**[When the electric wiring work is not finished]**

- The electric wiring works (including earthing) must be carried out by a qualified electrician.

- If a qualified person is not present, after the electric wiring work is finished, check the drainage according to the method specified in [When the electric wiring work is finished].

1. Open the control box lid and connect the single phase 230 V power supply to the terminal (L, N) on the terminal block (X2M). Connect the earth wiring to the earth terminal.
2. Make sure the control box lid is closed before turning on the power supply.
  - Throughout the whole process, carry out the work giving caution to the wiring around the control box so that the connectors may not come off.
3. Gradually pour 1 liter of water from the air outlet on the left side of the drain socket into the drain pan giving caution to avoid splashing water on the electric components such as drain pump. (Refer to Fig. 15)
4. When the power supply is turned on, the drain pump will operate. Drainage can be checked at the transparent part of the drain socket. (The drain pump will automatically stop after 10 minutes.)  
The drainage of water can be confirmed with water level change in the drain pan through the access window.
  - Do not connect the drain piping directly to the sewage that gives off ammonia odor. The ammonia in the sewage may go through the drain piping and corrode the heat exchanger of the indoor unit.
  - Do not apply external force to the float switch. (It may result in malfunction)
  - Do not touch the drain pump. Touching the drain pump may cause electric shocks.
  - Do not apply external force to the float switch. External force may cause a float switch malfunction.
5. Turn off the power supply after checking drainage, and remove the power supply wiring.
6. Attach the control box lid as before.

- On the completion of the drainage check, refer to the following illustration, and use the provided large sealing pad (5) and heat insulate the metal clamp (1) and drain hose (2)

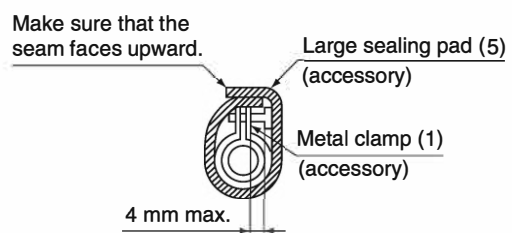

Fig. 16

## 8. DUCT WORK

Pay utmost attention to the following items and conduct the ductwork.

- Check that the duct is not in excess of the setting range of external static pressure for the unit. (Refer to the technical datasheet for the setting range.)
- Attach a canvas duct each to the air outlet and air inlet so that the vibration of the equipment will not be transmitted to the duct or ceiling.  
Use a sound-absorbing material (insulation material) for the lining of the duct and apply vibration insulation rubber to the hanging bolts.
- At the time of duct welding, perform the curing of the duct so that the sputter will not come in contact with the drain pan for the filter.
- If the metal duct passes through a metal lath, wire lath, or plate of a wooden structure, separate the duct and wall electrically.
- Be sure to heat insulate the duct for the prevention of dew condensation. (Material: Glass wool or styrene foam; Thickness: 25 mm)
- Explain the operation and washing methods of the locally procured components (i.e., the air filter, air inlet grille, and air outlet grille) to the customer.
- Locate the air outlet grille on the indoor side for the prevention of drafts in a position where indirect contact with people.
- The air conditioner incorporates a function to adjust the fan to rated speed automatically. **(10. FIELD SETTING)**  
Therefore, do not use booster fans midway in the duct.

### Connection method of ducts on air inlet and outlet sides.

- Connect the field supply duct in alignment with the inner side of the flange.
- Connect the flange and unit with the flange connection screw (3).
- Wrap aluminum tape around the flange and duct joint in order to prevent air leakage.

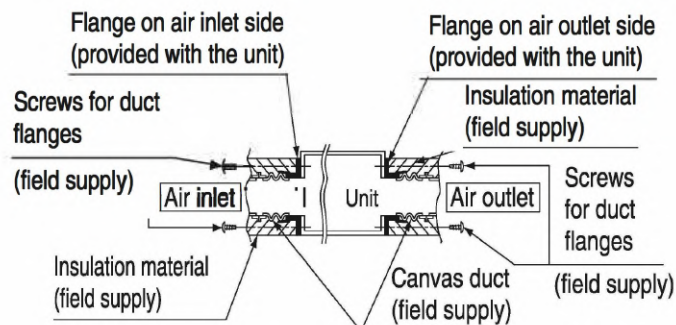

Fig. 17

### CAUTION

Connect the flange and unit with the flange connection screw field supply regardless of whether the duct is connected to the air inlet side.

## 9. ELECTRIC WIRING WORK

### 9-1 GENERAL INSTRUCTIONS

- Make certain that all electric wiring work is carried out by qualified personnel according to the applicable legislation and this installation manual, using a separate dedicated circuit.  
Insufficient capacity of the power supply circuit or improper electrical construction may lead to electric shocks or a fire.
- Make sure to install an earth leakage breaker.  
Failure to do so may cause electric shocks and a fire.
- Do not turn on the power supply (branch switch, branch overcurrent circuit breaker) until all the works are finished.
- Multiple number of indoor units are connected to one outdoor unit. Name each indoor unit as A-unit, B-unit ..... and the like. When these indoor units are wired to the outdoor unit, always wire the indoor unit to the terminal indicated with the same symbol on the terminal block. If the wiring and the piping are connected to the different indoor units and operated, it will result in malfunction.
- Make sure to earth the air conditioner.  
Earthing resistance should be according to applicable legislation.
- Do not connect the earth wiring to gas or water pipings, lightning conductor or telephone earth wiring.
  - Gas piping ..... Ignition or explosion may occur if the gas leaks.
  - Water piping ..... Hard vinyl tubes are not effective earths.
  - Lightning conductor or telephone earth wiring ..... Electric potential may rise abnormally if struck by a lightning bolt.
- For electric wiring work, refer to also the "WIRING DIAGRAM" attached to the control box lid.
- Carry out wiring between the outdoor units, indoor units and the remote controllers according to the wiring diagram.
- Carry out installation and wiring of the remote controller according to the "installation manual" attached to the remote controller.
- Do not touch the Printed Circuit Board assembly. It may cause malfunction.

### 9-2 SPECIFICATION FOR FIELD SUPPLY FUSES AND WIRING

Table 4

Model	Power supply wiring			Remote controller wiring Transmission wiring	
	Field fuses 	Wiring	Size	Wiring	Size
FDMFQ50AV16 FDMFQ71AV16 FDMFQ90AV16 FDMFQ100AV16 FDMFQ125AV16 FDMFQ140AV16	15A	H05VV-U3G  NOTE 1)	Wiring size and length must comply with local codes or IEC60335-1 (Table 11).	Vinyl cord with sheath or cable (2 core)  NOTE 2)	0.75-1.25 mm <sup>2</sup>

The lengths of remote controller wiring are as follows:

Remote controller wiring (indoor unit - remote controller)....Max. 500 m

### NOTE

1. Shows only in case of protected piping. Use H07RN-F in case of no protection. (Supply cords shall not be lighter than polychloroprene sheathed flexible cord (code designation 60245 IEC 57)).
2. Vinyl cord with sheath or cable (Insulated thickness : 1 mm or more)

### 9-3 WIRING CONNECTION METHOD

#### ⚠ CAUTION FOR WIRING

- For connection to the terminal block, use ring type crimp style terminals with insulation sleeve or insulate the wirings properly.

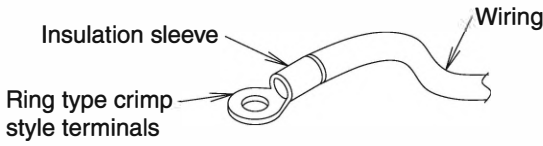
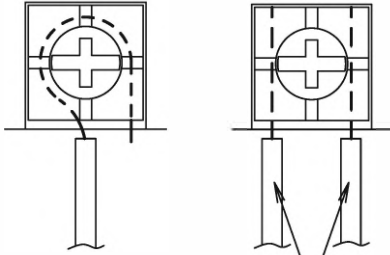

Fig. 18

- Connect the terminal as shown in Fig. 19.
- Do not carry out soldering finish when stranded wirings are used. (Otherwise, the loosening of wiring may result in abnormal heat radiation.)



Use wirings same in size  
(if the air conditioner is  
in simultaneous multi operation)

Fig. 19

(Abnormal heating may occur if the wirings are not tightened securely.)

- Use the required wirings, connect them securely and fix these wirings securely so that external force may not apply to the terminals.
- Use a proper screw driver for tightening the terminal screws. If an improper screw driver is used, it may damage the screw head and a proper tightening cannot be carried out.
- If a terminal is over tightened, it may be damaged. Refer to the table shown below for tightening torque of terminals.

Table 5

	Tightening torque (N·m)
Terminal block for remote controller and transmission wirings	0.88 ± 0.08
Terminal for power supply	1.47 ± 0.14
Earth terminal	1.47 ± 0.14

- Do not carry out soldering finish when stranded wirings are used.

#### ⚠ WARNING

- When wiring, form the wirings orderly so that the control box lid can be securely fastened. If the control box lid is not in place, the wirings may come out or be sandwiched by the box and the lid and cause electric shocks or a fire.

#### (1) Remove the control box lid.

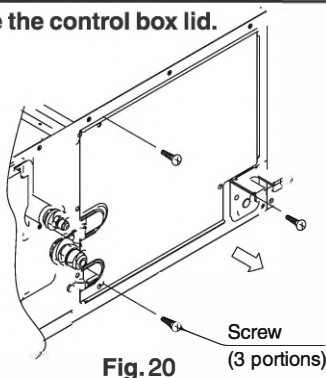

Fig. 20

Screw  
(3 portions)

#### (2) Connect the wiring into the control box through the wiring intake beside the control box.

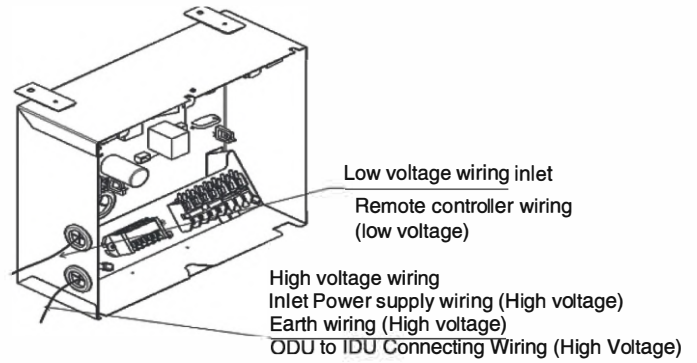

Fig. 21

#### (3) Follow the instructions below and perform wiring in the control box.

Power supply terminals (X1M, X2M)

Outdoor unit	Indoor unit
1 2 3	1 2 3
Terminal block	Terminal block

**Match the numbers**

Connection method of wiring between the indoor and outdoor units

Terminal block (X1M) for wiring between the indoor and outdoor units

Terminal block (X2M) for power supply wiring

Connection method for wiring between the indoor and outdoor units, and earth wiring

Securely fix the wiring to the provided plastic band with cable tie.

Remote controller wiring (low voltage)

Connect the wiring through the control box up to the sheathed part.

Wiring between the indoor and outdoor units (high voltage)

Earth wiring (high voltage)

Power supply wiring (high voltage)

Terminal block (X3M) for remote controller wiring

Remote controller wiring

No polarity

<Remote controller wiring method>

**Prohibited**

Do not connect wiring between the indoor and outdoor units (high voltage).

Fig. 22

#### (4) Mount the control box lid and wrap the wire sealing material (small) (9) so that the wiring through hole will be covered by the sealing material.

- Seal the clearance around the wirings with putty or insulating material (field supply). (If insects and small animals get into the indoor unit, short-circuiting may occur inside the control box.)

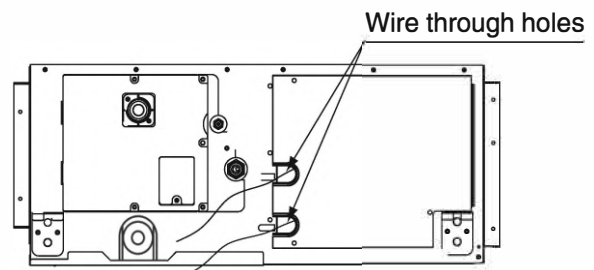

Fig. 23

(5) Mount the provided wire fixing bracket(10)with the wire fixing screw(11).Fix each wire with the provided clamp(7).

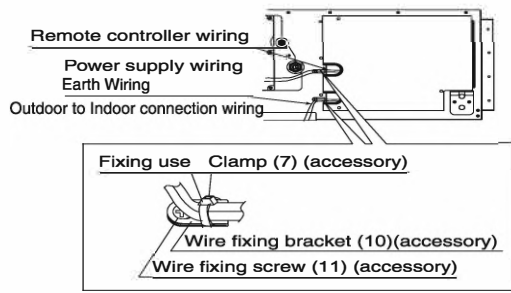

Fig. 24

**WIRING EXAMPLE**

**CAUTION**

Be sure to install an earth leakage breaker to the outdoor unit. This is to avoid electric shocks or a fire.

For the wiring of outdoor units, refer to the installation manual attached to the outdoor units. Confirm the system type.

- **Pair type:**  
1 remote controller controls 1 indoor unit (standard system).

(Refer to Fig. 25)

2 remote controllers control 1 indoor unit.

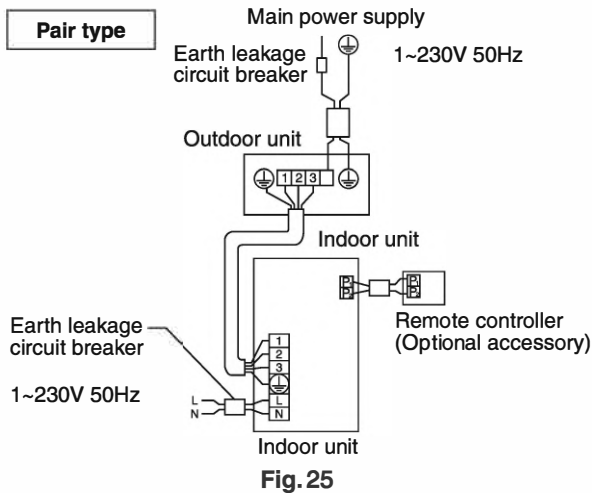

Fig. 25

**NOTE**

1. Terminal numbers of outdoor and indoor units must be matched.
- 2-1. Connect the remote controller only to the master unit.
- 2-2. The indoor temperature sensor is effective only for indoor units to which the remote controller is connected.
- 2-3. The length of wiring between the indoor unit and the outdoor unit varies depending on the connected model, the number of connected units, and the maximum piping length.  
For details, refer to the technical documents.

**Wiring Method for Wired Remote**

- (1) Remove the control box lid.
- (2) Connect wiring between the terminals (P1, P2) inside the control box for the remote controller. (There is no polarity.)  
(Refer to Fig. 26)

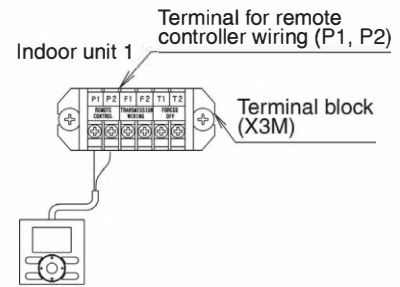

Fig. 26

**NOTE**

- Terminal numbers of outdoor and indoor units must be matched.

## 10. FIELD SETTING

### ⚠ CAUTION

Before carrying out field setting, check the items mentioned in **1. Items to be checked after the installation work is completed** on page 37.

- Check if all the installation and piping works for the air conditioner are completed.
- Check that the outside panel and piping cover of the indoor and outdoor units are closed.

### < FIELD SETTING >

**After turning on the power supply, carry out field setting from the remote controller according to the installation state.**

- Carry out setting at 3 places, "Mode No.", "FIRST CODE No." and "SECOND CODE No."  
The settings shown by  in the following tables indicate those when shipped from the factory.
- The method of setting procedure and operation is shown in the installation manual attached to the remote controller.  
(Note) Though setting of "Mode No." is carried out as a group, if you intend to carry out individual setting by each indoor unit or confirmation after setting, carry out setting with the Mode No. shown in the parenthesis ( ).
- Ask your customer to keep the manual attached to the remote controller together with the operation manual.
- Do not carry out settings other than those shown in the table.
- Settings are performed by selecting "Mode No.", "FIRST CODE No.", and "SECOND CODE No."

### 10-1 Settings for external static pressure

- Make settings in either method (a) or method (b).  
**(a) Make settings with Air volume automatic adjustment function.**  
"Air volume automatic adjustment" function: The air volume is adjusted to the rated air volume automatically.

### ⚠ CAUTION

- Be sure to check that the external static pressure is within the specification range before making settings. The external static pressure will not be automatically adjusted and air volume insufficiency or water leakage may result if the external static pressure is outside the range. (Refer to the technical document for the setting range of external static pressure.)
- (1) Check that the electrical wiring and duct work have been completed.  
(If the closing damper is set midway, be sure to check that the damper is opened. Furthermore, check that the air passage on the suction side is provided with an air filter (field supply)).
  - (2) If air conditioner has more than one air outlet and air inlet, be sure to make adjustments so that the air volume ratio of each air outlet and the corresponding air inlet will conform to the designed air volume ratio.  
In that case, set the operating mode to "Fan". (In the case of changing the air volume, press the fan speed button on the remote controller and change the current selection to "High", "Medium", or "Low".)

- (3) Make settings to adjust the air volume automatically.  
After setting the operating mode to "Fan", set the air conditioner to field setting mode with the operation of the air conditioner stopped. Select Mode No. [21] (11 in the case of batch settings), select FIRST CODE No. "7", and set the SECOND CODE No. to "03".  
Return to the "Basic screen" ("Normal mode" if a wireless remote controller is used), and press the ON/OFF button.  
The operation lamp is lit, and the indoor unit will go into fan operation for air volume automatic adjustments (at which time, do not adjust the opening of the air outlet or inlet).  
The air volume adjustments will automatically terminate approximately 1 to 15 minutes after the indoor unit comes into operation, and the operation lamp will be OFF and the indoor unit will come to a stop.

Table 6

Mode No.	FIRST CODE No.	Setting content	SECOND CODE No.		
			01	02	03
11 (21)	7	Air volume adjustment	OFF	Air volume adjustment completion	Air volume adjustment start

- (4) After the air conditioner comes to a stop, be sure to check with Mode No. [21] per indoor unit that the above SECOND CODE No. is "02". If the operation of the air conditioner does not stop automatically or the SECOND CODE No. is not set to "02", repeat the setting procedure from (3). If the remote controller displays an error, refer to **11-1 HOW TO DIAGNOSE FOR PROBLEMS** and check the error.

### ⚠ CAUTION

- If airflow pathway changes, such as duct and air outlet changes, are made after air volume adjustments, be sure to make "Air volume automatic adjustment" again.
- If airflow pathway changes, such as duct and air outlet changes, are made after **11. TEST OPERATION** or air conditioner relocation, contact your dealer.

- (b) **Select external static pressure with the remote controller.**  
Check with Mode No. [21] per indoor unit that the SECOND CODE No. for the above "Air volume adjustment" is set to "01" (OFF). (The SECOND CODE No. is factory set to "01" (OFF).) Change the SECOND CODE No. by referring to the table below according to the external static pressure of the duct to be connected.

Table 7

External static pressure	Mode No.	FIRST CODE No.	SECOND CODE No.
50Pa	13 (23)	6	05
60Pa			06
70Pa			07
80Pa			08
90Pa			09
100Pa			10
110Pa			11
120Pa			12
130Pa			13
140Pa			14
150Pa			15



## 10-2 SETTING WHEN AN OPTIONAL ACCESSORY IS ATTACHED

- For setting when attaching an optional accessory, refer to the installation manual attached to the optional accessory.

## 10-3 SETTING FAN SPEED DURING THERMOSTAT OFF

- Set the fan speed according to the using environment after consultation with your customer.
- When the fan speed is changed, explain the set fan speed to your customer.

Table 8

Setting		Mode No.	FIRST CODE No.	SECOND CODE No.
State of fan in operation with thermostat OFF (cooling and heating)	Normal	11 (21)	2	01
	Stop			02
Fan speed during cooling thermostat OFF	LL (Extra low)	12 (22)	6	01
	Setting			02
Fan speed during heating thermostat OFF	LL (Extra low)	12 (22)	3	01
	Setting			02

## 10-4 SETTING FILTER SIGN

- A message to inform the air filter cleaning time will be indicated on the remote controller.
- Set the SECOND CODE No. shown in the Table 9 according to the amount of dust or pollution in the room.
- The periodical filter cleaning time can be shortened depending on the environment.

Table 9

Contamination	Hours until indication	Mode No.	FIRST CODE No.	SECOND CODE No.	
Normal	Approx. 2500 hrs	10 (20)	0	01	
More contaminated	Approx. 1250 hrs			02	
With indication			3	3	01
No indication*					02

\* Use "No indication" setting when cleaning indication is not necessary such as the case of periodical cleaning being carried out.

## 10-5 Remote control settings (forced stop or start-stop control)

- Change the SECOND CODE No. by referring to the table below in the case of remote control.

Table 10

Setting content	Mode No. (Note)	FIRST CODE No.	SECOND CODE No.
Forced stop	12 (22)	1	01
Start-stop control			02

### <In the case of using a wireless remote controller>

- In the case of using a wireless remote controller, address settings for the wireless remote controller are required in addition to the above. For settings, refer to the operation manual provided with the wireless remote controller.

Table 11

Setting	Mode No.	FIRST CODE No.	SECOND CODE No.
Pair system (1-unit)	11 (21)	0	01

### < Procedure >

- in the tables indicates factory settings.  
(Note) The "Mode No." is set on a group basis. To individually set a Mode No. for each indoor unit or confirm the settings, set the Mode No. in the parenthesis.

### NOTE

- Terminal numbers of outdoor and indoor units must be matched.

## 11. TEST OPERATION

**Complete all the 1. Items to be checked after the installation work is completed on page 37. Please also refer to the installation manual attached to outdoor unit.**

- The settings of BRC1E model remote controller should be performed while referring to the manual attached to the remote controller.
- The settings of the wireless remote controller should be switched in accordance with the following procedure.
  - Make sure that the installation work for the indoor and outdoor units are all completed.
  - Make sure that the following items are all closed: the control box lid of the indoor unit and the outer board and piping cover of the outdoor unit.
  - After completing the refrigerant piping, drain piping, and electrical wiring, clean the interior of the indoor unit and front panel. Next, perform test operation in accordance with the installation manual attached to the outdoor unit in order to protect the unit. (It is recommended that the test operation is performed in the presence of qualified electrical technician or engineer.)
  - In test operation, make sure that fan speed can be obtained according to the settings.
  - If interior work is still unfinished when test operation finishes, explain to the customer that the air conditioner must not be operated until interior work is completed in order to protect the indoor units.  
(If the indoor unit is operated under this condition, paint, glue, and other materials used during the interior finishing work will contaminate the indoor unit. This may cause water splashes or leakage.)
  - If a malfunction occurs and the air conditioner cannot operate, refer to **11-1 HOW TO DIAGNOSE FOR PROBLEMS.**
  - After completing the test operation, press the INSPECTION/TEST OPERATION button once to put the indoor unit in inspection mode, and make sure the malfunction code is "00" (= normal).  
If the code reads anything other than "00", refer to **11-1 HOW TO DIAGNOSE FOR PROBLEMS.**
  - Press the INSPECTION/TEST OPERATION button four times to return to normal operation mode.

## [Mode switching]

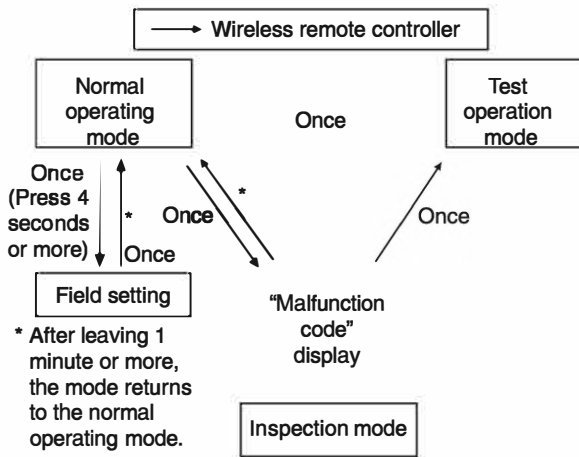

Fig. 33

### 11-1 HOW TO DIAGNOSE FOR PROBLEMS

With the power on, troubles can be monitored on the remote controller.

The fault diagnosis for BRC1E model remote controller should be performed while referring to the installation manual supplied with the remote controller. For the other remote controllers, perform the fault diagnosis using the following procedure.

■ Trouble shooting with the remote controller display.

1. With the wireless remote controller.

(Also refer to the operation manual attached to the wireless remote controller.)

When the operation stops due to trouble, the display on the indoor unit flashes. In such a case, diagnose the fault contents with the table on the Malfunction code list looking for the Malfunction code which can be found by following procedures. (NOTE 1)

- (1) Press the INSPECTION /TEST OPERATION button, "👁️" is displayed and "0" flashes.
- (2) Press the PROGRAMMING TIME button and find the unit no. which stopped due to trouble.  
Number of beeps 3 short beeps  
.....Perform all the following operations  
  1 short beep  
.....Perform (3) and (6)  
  1 long beep  
.....No trouble
- (3) Press the OPERATION MODE SELECTOR button and upper figure of the malfunction code flashes.
- (4) Continue pressing the PROGRAMMING TIME button unit it makes 2 short beeps and find the upper code.
- (5) Press the OPERATION MODE SELECTOR button and lower figure of the malfunction code flashes.
- (6) Continue pressing the PROGRAMMING TIME button unit it makes a long beep and find the lower code.
  - A long beep indicate the malfunction code.

### NOTE 🗨️

1. When the ON/OFF button is kept pressed for 5 seconds or longer during the inspection mode, the above trouble history indication disappears. In this case, after the malfunction code indication flashes twice, the indication of code becomes "00" (normal) and unit NO. becomes "0". Then, the display automatically changes from the inspection mode to the normal mode.

### ⚠️ CAUTION

After test operation is completed, check the items mentioned in the clause 2. **Items to be checked at delivery** on page 38.  
If the interior finish work is not completed when the test operation is finished, for protection of the air conditioner, ask the customer not operate the air conditioner until the interior finish work is completed. If the air conditioner is operated, the inside of the indoor units may be polluted by substances generated from the coating and adhesives used for the interior finish work and cause water splash and leakage.

### ⚠️ To the operator carrying out test operation

After test operation is completed, before delivering the air conditioner to the customer, confirm that the control box lid is closed.  
In addition, explain the power supply status (power supply ON/OFF) to the customer.

### 11-2 DECLARED RATINGS

**Rated Values:** Please do not refer the Capacity/Input Power/Current/Electricity Consumption mentioned on Outdoor unit rating label when this Outdoor is connected with Inverter Duct Indoor series. (FDMFQ-AV16+RZMFQ-AV16).

Please refer below table for Capacity/Input Power/Current of RZMFQ-AV16 outdoor unit when connected with FDMFQ-AV16 Indoor unit.

RATED VALUES	UOM	FDMFQ50AV16 + RZMFQ30AV16		FDMFQ71AV16 + RZMFQ71AV16		FDMFQ90AV16 + RZMFQ90AV16		FDMFQ100AV16 + RZMFQ100AV16	
Cooling Capacity (Full Load or 100%)	KW	5.2	7.1	9.0	10.5				
Input Power (Full Load or 100%)	KW	1.66	2.24	2.9	3.8				
Current	A	7.73	10.4	14	18.36				

### 12. MALFUNCTION CODE

- For places where the malfunction code is left blank, the "👁️" indication is not displayed. Though the system continues operating, be sure to inspect the system and make repairs as necessary.
- Depending on the type of indoor or outdoor unit, the malfunction code may or may not be displayed.

Code	Malfunction/Remarks
A0	Safety device operates
A1	Indoor unit's PC board faulty
A3	Drain water level abnormal
A6	Indoor fan motor overloaded, overcurrent or locked
A8	Fan PCB power supply error
AF	Humidifier faulty
AH	Air cleaner faulty
	Only the air cleaner does not function.
AJ	Type set improper
	Capacity data is wrongly preset. Or there is nothing programmed in the data hold IC.
C1	Indoor PCB (Master) - indoor PCB (Slave) transmission defect
C4	Sensor (R2T) for heat exchanger temperature is fault
C5	Sensor (R3T) for heat exchanger temperature is fault
C6	Fan PCB setting defect
C9	Sensor for suction air temperature is fault
CC	Humidity sensor abnormal
CE	Human detection / floor temperature sensor error
CJ	Sensor for remote controller is fault
	The remote controller thermistor does not function, but the system thermo run is possible.
U1	Reverse phase / Reverse two phase of the L1, L2 and L3
UF	Wrong wiring between indoor and outdoor units or malfunction of PC board mounted on indoor and the outdoor units
	transmission Error (indoor unit - remote controller)
U8	Malfunction in transmission between main and sub remote controls (Malfunction in sub remote controller)
UA	Miss setting for multi setting
	Setting is wrong for selector switch of multi-system. (See SS2 on main unit's PC board)
UC	Central control address overlapping
UE	Transmission defect (indoor - centerlizing)_
UJ	Peripheral equipment transmission fault
U0	Refrigerant shortage / Suction pipe temperature abnormal.
U2	Low-voltage detection or over-voltage detection / Includes the defect in 52C
U4	Signal transmission error (between indoor unit and ODU)
UA	Miss setting for multi system
	Setting is wrong for selector switch of multi-system (see switch SS2 on the main unit's PC board)
E1	Outdoor unit PCB abnormality
E7	Outdoor fan motor lock malfunction / outdoor fan instantaneous over current malfunction.
F3	Discharge pipe temperature control (Outdoor Unit)
H9	Outdoor air thermistor faulty / equipment operation in response to error will vary according to model
J3	Discharge pipe thermistor faulty (outdoor unit) / e equipment operation in response to error will vary according to model
J6	Heat exchanger thermistor faulty / equipment operation in response to error will vary according to model
L4	over heated radiation fin / inverter cooling defect

L5	instantaneous over current/possible earth fault or short circuit in the compressor motor
L6	Compressor lock (Outdoor Unit)
L8	Input-over- current detection (outdoor Unit)
F6	High pressure control in cooling (outdoor unit)
00	Normal
E5	OL activation (Compressor overload) (Outdoor Unit)
F8	System shutdown due to temperature abnormality in compressor (Outdoor Unit)
H0	Compressor sensor system abnormality (outdoor Unit)
H6	Position sensor abnormality (Outdoor Unit)
H8	DC voltage/current sensor abnormality (Outdoor Unit)
L3	Reactor thermistor error outdoor
P4	Radiation fin thermistor or related abnormality (Outdoor Unit)
<b>J7</b>	Heat exchanger thermistor faulty (outdoor unit)
	Equipment operation in response to errors will vary according to model.
<b>J8</b>	Liquid piping temperature sensor system error (outdoor unit)
<b>J9</b>	Intake temperature sensor error (outdoor unit)
L1	Inverter system error (outdoor unit)
L3	Reactor thermister error (outdoor)
L4	Overheated heat-radiating fin (outdoor unit)
	Inverter cooling defect.
L5	Instantaneous overcurrent (outdoor unit)
	Possible earth fault or short circuit in the compressor motor.
L8	Electric thermal (outdoor unit)
	Possible electrical overload in the compressor or cut line in the compressor motor.
L9	Stall prevention (outdoor unit)
	Compressor possibly locked.
LC	Transmission malfunction between the outdoor control units' inverters (outdoor unit)
P1	Open-phase (outdoor unit)
P3	P-board temperature sensor malfunction (outdoor unit)
P6	DC output current error (outdoor)
PJ	Type set improper (outdoor unit)
	Capacity data is wrongly preset. Or there is nothing programmed in the data hold IC.
U0	suction pipe temperature abnormal

### 13. CAUTION (RZMFQ50,71AV16)

**THIS IS NECESSARY FOR AFTER SERVICE, SO PLEASE REQUEST CUSTOMER TO KEEP THIS PAPER.**

#### CAUTION (NEW REFRIGERANT (R32 SERIES))



#### ⊙ Caution about electric shock when do service inspection.

1. After intercept power supply, do not open outside panel for 10 minutes.
2. Follow manufacturing label on electric box cover, please take off outdoor fan motor connector to confirm voltage and body static electricity discharge.

#### ⊙ General caution items when do service inspection

##### Caution to confirm compressor and fan motor running

Do not directly connect power input ( 1/3 Phase 50Hz ) to compressor and fan motor. (If not connect to print board (PCB), compressor and fan motor will be burned cut.)

##### Caution when recharge refrigerant

1. To prevent the mixing of impurities, pressure resistance and contamination mix, please use manifold gauge especially for R32.
2. Make sure to do Nitrogen blow if brazing when flare connection.  
Apply ether oil or ester oil at inside flare only.
3. Do air tight test at 4.1 7MPa
4. Do dry vaccum, make sure to charge refrigerant in liquid condition from liquid side service port. (Compressor will be broken if charge from gas side service port.)

##### Caution when use outdoor PCB

Make sure to touch earth terminal and earthed metal before touch pcb, to prevent electric shock.

##### Caution when break down diagnosis from letter code in remote control

Please refer to service guide or outdoor unit installation manual.

### Charging refrigerant

#### • Charging the system with refrigerant

(For more information such as calculation method of additional refrigerant charge, additional charge method, refrigerant charge caution, refer to the Installation Manual and Technical Guide.)

- For refrigerant charge, be sure to charge from the service port of the liquid side stop valve in liquid states. (If you charge from the service port of the gas side stop valve, it may break the compressor.)
- Never charge other than the specified refrigerant. (It may cause fire and bursting.)

Table 1. Chargeless piping length

Liquid piping size	Pipe length which is not required additional charging
φ6.35 x t0.8mm	10m

#### 1. In case of additional refrigerant charging

Please add refrigerant amount according to the following table.

Outdoor	Liquid piping size	Pipe length which is not required additional charging	Additional ref. amount	Max. Pipe Length
			above 10mtr.	20mtr
RZMFQ50,71AV16	φ6.35 x t0.8mm	10m	20gm/mtr	20mtr

#### 2. Total refrigerant charging (Details please see service guide)

1. Please recover the refrigerant until becoming 0.09 Mpa (gauge pressure: -0.011MPa) or less by the refrigerant recovery machine from stop valve service port (liquid-gas side) at the same time.
2. Exchange service parts · Modify leak point.
3. Perform airtightness test air-purge.  
Please refer installation manual of outdoor unit or service guide.
4. Charge refrigerant amount selected by table 2 from liquid stop valve service port.

**Caution** Do not turn on power during evacuation. The motor may be damaged due to vacuum discharge.

Table 2 Charge refrigerant amount (After a leak etc...)

Outdoor	Liquid piping size	Piping length, R32 complete additional amount (kg)	
		5-10m	20m
RZMFQ50AV16	φ6.35 x t0.8mm	850g	1050g
RZMFQ71AV16	φ6.35 x t0.8mm	1040g	1240g

#### • Making a record of the added refrigerant charge amount

Be sure to record the piping length and added refrigerant charge amount or refrigerant recharge amount with an oil-based or other indelible marker so the figures will not fade over time. This information is necessary for after service and maintenance.

Liquid piping size	φ6.35mm x t0.8mm
Refrigerant piping length	m
Additional refrigerant charging	kg
Recharge of refrigerant	kg

### How to execute a pumping-down

(for example when moving or reinstalling an indoor or outdoor unit)

The outdoor unit is equipped with a high pressure switch to protect the compressor.

**Caution** Never short-circuit the high pressure switch during pump-down operation.

- It is not allowed to let the refrigerant out into the air. The refrigerant should be recovered completely.
- Although pumping-down operation allows most of the refrigerant to be recovered in a short period of time, some refrigerant will remain inside the indoor unit and the refrigerant piping. Using a refrigerant recovery machine, recover remaining refrigerant from the stop valve service port until the pressure falls to 0.09MPa (gauge pressure: -0.011MPa) or less.
- Be sure to execute the pumping-down before refrigerant piping and wiring is taken off.

#### ⊙ For pumping-down operation

1. Please follow the [caution about electric shock when service inspection] which attached on Top panel (Caution : Do not take off the connector X106A)
2. To prevent electric shock, please protect power input terminal block by insulation sheet refer to below figure.
3. Turn on the power supply and carry out pumping-down operation according to the following procedure.

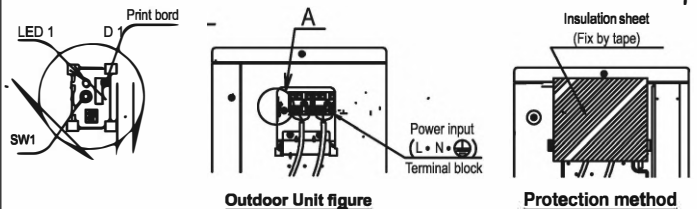

- ⚠ To prevent electric shock when inspection, protect by use insulation sheet on power input terminal block and print board A2P

#### ⊙ For pumping-down operation procedure

1. Remove the valve caps from the liquid stop valve and the gas stop valve.
2. By Long Pressing Switch button (SW1) on PCB for 5 sec then unit will go on pump down operation & LED continuous fast blinking on PCB (A2P) .
3. Close the liquid stop valve with a hexagonal wrench.
4. After 2 to 3 minutes, close the gas stop valve and Turn off the main power supply this will automatically deactivate the Pump Down operation.

Pump down operation is allowed on below 2 conditions:-

- (1) The outdoor unit is not abnormal and not in the 3-minute standby mode.
- (2) The outdoor unit is not operating.

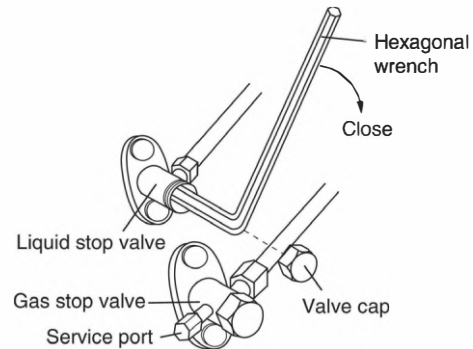

- ⚠ When installing and relocating, be sure to install the earth leakage breaker to protect from the electric shock disaster and fire due to leakage of electricity. For installing the earth leakage breaker, request to the qualified electrician.

### 13.1 CAUTION (RZMFQ90,100AV16)

**THIS IS NECESSARY FOR AFTER SERVICE, SO PLEASE REQUEST CUSTOMER TO KEEP THIS PAPER.**

#### CAUTION (NEW REFRIGERANT (R32 SERIES))

**WARNING**

**ELECTRIC SHOCK CAUTION**

**⊙ Caution about electric shock when do service inspection.**

1. After intercept power supply, do not open outside panel for 10 minutes.
2. Follow manufacturing label on electric box cover, please take off outdoor fan motor connector to confirm voltage and body static electricity discharge.

**⊙ General caution items when do service inspection**  
**Caution to confirm compressor and fan motor running**  
 Do not directly connect power input (1/3 Phase 50Hz) to compressor and fan motor. (If not connect to print board (PCB), compressor and fan motor will be burned cut.)

**Caution when recharge refrigerant**

1. To prevent the mixing of impurities, Pressure resistance and contamination mix, please use manifold gauge especially for R32.
2. Make sure to do Nitrogen blow if brazing when flare connection. Apply ether oil or ester oil at inside flare only.
3. Do air tight test at 4.0MPa
4. Do dry vacuum.

**Caution when use outdoor PCB**  
 Make sure to touch earth terminal and earthed metal before touch pcb, to prevent electric shock.

**Caution when break down diagnosis from letter code in remote control**  
 Please refer to service guide or outdoor unit installation manual.

#### Charging refrigerant

**• Charging the system with refrigerant**  
 (For more information such as calculation method of additional refrigerant charge, additional charge method, refrigerant charge caution refer to the Installation Manual and Technical Guide)

Never charge other than the specified refrigerant. (It may cause fire and bursting.)

Tabel1.In case of additional refrigerant charging

Outdoor	Liquid piping size	Pipe length which is not required additional charging	Additional ref. amount		Max. pipe length
			25m or less	30m or less	
RZMFQ90, 100AV16	ø9.5 x t0.8 mm	15mtr	0.25	0.375	30 mtr

**Total refrigerant charging (Details please see service guide)**

1. Please recover the refrigerant until becoming 0.09 Mpa (gauge pressure:- 0.011MPa) or less by the refrigerant recovery machine from stop valve service port (liquid gas side) at the same time.
2. Exchange service parts: modify leak point.
3. Perform airtightness test air-purge.  
Please refer installation manual of outdoor unit or service guide.
4. Charge refrigerant amount selected by table 1 from liquid stop valve service port.

**Caution** Do not turn on power during evacuation. The motor may be damaged due to vacuum discharge.

- Making a record of the added refrigerant charge amount  
 Be sure to record the piping length and added refrigerant charge amount or refrigerant recharge amount with an oil-based or other indelible marker so the figures will not fade over time.  
 This information is necessary for after service and maintenance.

Liquid piping size	Ø9.5 mm x t0.8 mm
Refrigerant piping length	m
Additional refrigerant charging	kg
Recharge of refrigerant	kg

#### How to execute a pumping-down (for example, when moving or reinstalling an indoor or outdoor unit)

The outdoor unit is equipped with a high pressure switch to protect the compressor.  
**Caution** Never short-circuit the high pressure switch during pump-down operation.

- It is not allowed to let the refrigerant out into the air. The refrigerant should be recovered completely.
- Although pumping-down operation allows most of the refrigerant to be recovered in a short period of time, some refrigerant will remain inside the indoor unit and the refrigerant piping. Using a refrigerant recovery machine, recover remaining refrigerant from the stop valve service port until the pressure falls to 0.09MPa (gauge pressure-0.011MPa) or less.
- Be sure to execute the pumping-down before refrigerant piping and wiring is taken off.

- ⊙ For pumping-down operation**
- 1- Please follow the caution about electric shock when service inspection which attached on E-Box cover (Caution : Do not take off the connector S70)
  - 2- To prevent electric shock, please protect power input terminal block by insulation sheet refer to below figure.
  - 3- Turn on the power supply and carry out pumping-down operation according to the following procedure.

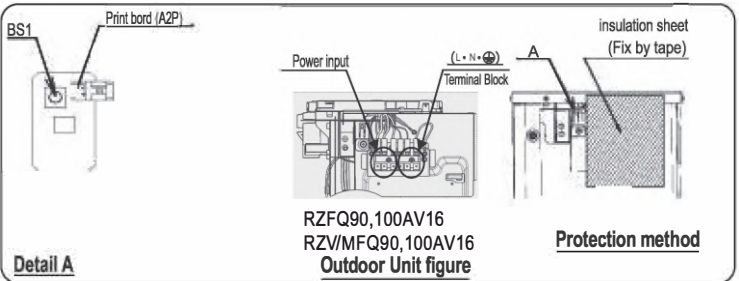

**⚠** To prevent electric shock when inspection, protect by use insulation sheet on power input terminal block and print board(A2P)

**⊙ For pumping-down operation**

**⚠** Do not remove the indoor unit until pump down operation finish. (It is dangerous when indoor fan automatically starts the operation.)  
 Perform pumping-down operation using the following procedure

procedure	Precaution
1. Caution that stop valves both on the liquid and gas sides are open.	
2. Push the pumping-down button (BS1) on the PC board of the outdoor unit for 5 seconds	Compressor and outdoor unit fan will start operation automatically door fan only auto-matically start running. pay attention to this.
3. Close the stop valve on the liquid side securely about 4 to 5 minutes after the compressor started operation. After 2 to 3 minutes, close th gas stop valve and push pump down button(BS1) for stop operation.	<ul style="list-style-type: none"> <li>•Do never leave the outdoor unit unattended with opened front panel when power supply is on.</li> <li>•In case the stop valve on the liquid side is not securely closed during compressor operation, pumping-down operation cannot be executed</li> </ul>
4. Turn off the power supply.	When you work alone, carry out after closing the front plate, After turning the power supply off, remove the insulation sheet.

- To force of operation, turn off the main power supply and turn it on again. Make sure that stop valves both on liquid and gas sides are open and be sure operate the unit in cooling operation during test run.

<Liquid side>

<Gas side>

**⚠** When installing and relocating, be sure to install the earth leakage breaker to protect from the electric shock disaster and fire due to leakage of electricity. For installing the earth leakage breaker, request to the qualified electrician.

## 13.2 CAUTION (RZMFQ125,140AY16. RZFQ125, 140AY16)

### ● Caution when servicing the switch box

1. Be sure to check using a tester that the power supply is turned off at a terminal strip before service inspection.
2. Be aware that temperature of switch boxes can be extremely high.
3. Do not touch the switch box for another 10 minutes after turning off the circuit breaker. Even after 10 minutes, always measure the voltages at the terminals of main circuit capacitor or electrical parts and make sure that those voltages are 50V DC or less.  
(Always touch the earth terminal first before pulling out or plugging in connectors in order to discharge static electricity. This to prevent the PCB from being damaged.)

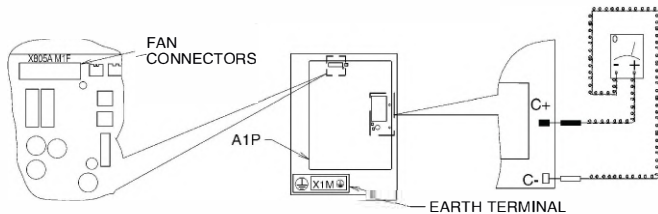

4. After confirming the main circuit capacitor voltage drop, pull out the outdoor unit fan connector, make sure not to touch any live parts during this action. (strong adverse winds which let the outdoor unit fan rotate, induce a risk of electrical shock because the fan rotation makes the capacitor store electricity.)

### ● Caution when performing other servicing

Do never connect power supply cables to compressors (U,V,W) or fan motor directly. (Failure to connect the power supply to the PC board may cause the compressor or fan motor to burn out.)

### ● Total refrigerant charging (Details please see service manual) in case of RZFQ125,140 Y series

#### ① Turn ON refrigerant recovery mode by remote control

Please refer [field setting] from remote control installation manual.

Setting content	Mode No.	Setting switch No.	Setting position No.	
Refrigerant recovery mode setting	16(26)	7	01	03
			OFF	ON

#### ② After setting ①, power supply will be intercepted after 1 minute passed.

※ It turn on power supply before ③ ~ ⑥ are completed refrigerant recovery mode is turned OFF, the refrigerant cannot be recovered or charged regularly. In case charge power supply unwillingly, please set refrigerant mode as ON by remote control again.

#### ③ Please recover the refrigerant until becoming 0.09Mpa (gauge pressure: -0.011 Mpa) or less by the refrigerant recovery machine from stop valve service port (liquid . gas side) at the same time.

#### ④ Exchange service parts modify leak point.

#### ⑤ Perform airtightness test . air- purge.

Please refer installation manual of outdoor unit or service manual.

#### ⑥ Charge refrigerant amount selected by table 1 from liquid stop valve service port.

**Caution** Do not turn on power during evacuation. The motor may be damaged due to vacuum discharge.

※ In other hands, Recovery mode can set from button at outdoor side.

Table 1. Charge refrigerant amount (After a leak, etc...)

Outdoor	Liquid piping size	Piping length, R32 complete additional amount(KG)						
		5'10m	15m or less	25m or less	30m or less	35m or less		
RZFQ125,140 series	∅ 9.5 x t0.8mm	1.35	1.35	1.6	N/A	1.85	2.1	
RZMFQ125,140 series	∅ 9.5 x t0.8mm	2.1	2.1	2.35	2.475	N/A	N/A	

## How to execute a pumping-down

(for example, when moving or reinstalling an indoor or outdoor unit)

The outdoor unit is equipped with a high pressure switch to protect the compressor.

**Caution** Never short-circuit the high pressure switch during pump-down operation.

- It is not allowed to let the refrigerant out into the air. The refrigerant should be recovered completely.
- Although pumping-down operation allows most of the refrigerant to be recovered in a short period of time, some refrigerant will remain inside the indoor unit and the refrigerant piping. Using a refrigerant recovery machine, recover remaining refrigerant from the stop valve service port until the pressure falls to 0.09 MPa. (gauge pressure:- 0.011 MPa) or less.
- Be sure to execute the pumping-down before refrigerant piping and wiring is taken off.

### ● Preparation for pumping-down operation

1. Make sure to cut off power supply.  
Open the front panel and cover the PCB and terminal board with insulation sheet to avoid electric shock by accidental touching of live parts.
2. Close the front panel before leaving the outdoor unit. You cannot leave the unit unattended in case the front panel remains opened.
3. Turn on the power supply and carry out pumping-down operation according to the following procedure.

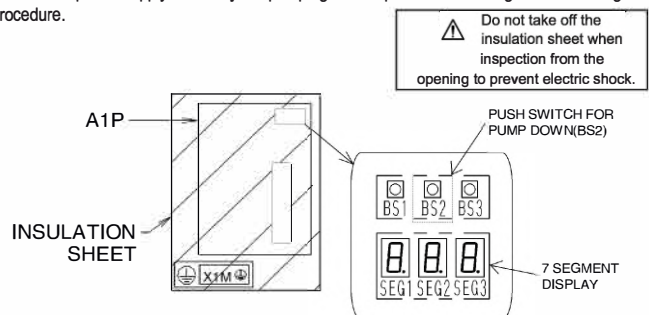

### ● For pumping-down operation

**Caution** Do not remove the indoor unit until pump operation finish. (It is dangerous when indoor fan automatically starts the operation.)

Perform pumping-down operation using the following procedure

	Procedure	Precaution
1	Confirm that stop valves both liquid and gas sides are open.	
2	Push the pumping-down button (BS2) on the PC board of the outdoor unit for 5 seconds.	Compressor and outdoor unit fan will start operation automatically. Indoor fan may automatically start running. Pay attention to this
3	Close the stop valve on the liquid side securely about 2 minutes after the compressor started operation.  Once the compressor operation stops after 2 to 5 minutes, close the stop valve on the gas side securely.	<ul style="list-style-type: none"> <li>● Do never leave the outdoor unit unattended with opened front panel when power supply is on.</li> <li>● In case the stop valve on the liquid side is not securely closed during compressor operation, pumping-down operation can not be executed.</li> </ul>
4	Turn off the power supply.	When you work alone, carry out after closing the front plate, After turning the power supply off, remove the insulation sheet.

- If after finishing pumping-down operation the outdoor unit does not operate, even when the remote controller switch is turned on, the remote controller and 7segment display may or may not indicate "U4" But it is not a malfunction.

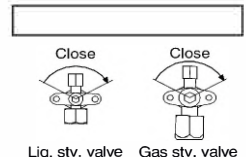

- When in need of operation, turn off the main power supply and turn it on again. make sure that stop valves both on liquid and gas sides are open and be sure to operate the unit is coding operation during test run.

**Caution** When installing and relocating, be sure to install the earth leakage breaker to protect from the electric shock disaster and fire due to leakage of electricity. For installing the earth leakage breaker, request to the qualified electrician.

## How to confirm of running condition by LED AND 7 SEGMENT DISPLAY

When power supply turns "ON", LED of printed board (A1P) of outdoor side can confirm details as following.

☀ : LED light ON    ● : LED light OFF    ⚡ : LED flash

HAP ●
Micon Normal Monitor

- ⚡ : Normal
- : Abnormal, power supply is abnormal (Insufficient voltage, breaker does not ON) or printed board (A1P) of outdoor has failure.
- ☀ : Abnormal, power supply is abnormal.
- ⚡ : Abnormal (Fast flashing)

Result	7segment display
Normality finish	Light off
Abnormality finish	Abnormal code

### 7 segment : For display error code detail

When test operation, 7 segment display will flashing same as right view, this symbol is not abnormal ( for normal or abnormal will display same right now)

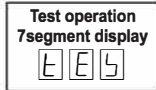

### Measure for abnormal finished

Confirm malfunction code from remote controller and 7 segment display, then correct the abnormal finished (for how to correct abnormality and correction method, see the installation/opertion/service manual). After correcting abnormal finished push the confirm button (BS3) and reset the malfunction code, then carry out the check again and confirm the abnormality is properly corrected (need to not show error code in remote controller and 7 segment display.)



This unit, while operation and stop, stand by power is decreasing, LED of outdoor PCB will be turn OFF. Power is still being supplied to terminal block while stand by power is decreasing, be make sure to turn OFF power supply when service.

### • Precautions regarding trouble diagnosis using the malfunction code on the remote controller and 7 segment display.

Please refer to the installation manual attached to indoor unit.

### Making a record of the added refrigerant charge amount

Be sure to record the piping length and added refrigerant charge amount or refrigerant recharge amount with an oil-based or other indelible marker so to the figures will not fade over time.

This information is necessary for after service and maintenance.

Liquid piping size	Ø 9.5mm x t0.8mm
Refrigerant piping size	m
Additional refrigerant charging	kg
Recharge of refrigerant	kg



# 14. HOW TO RE-USE THE EXISTING PIPING

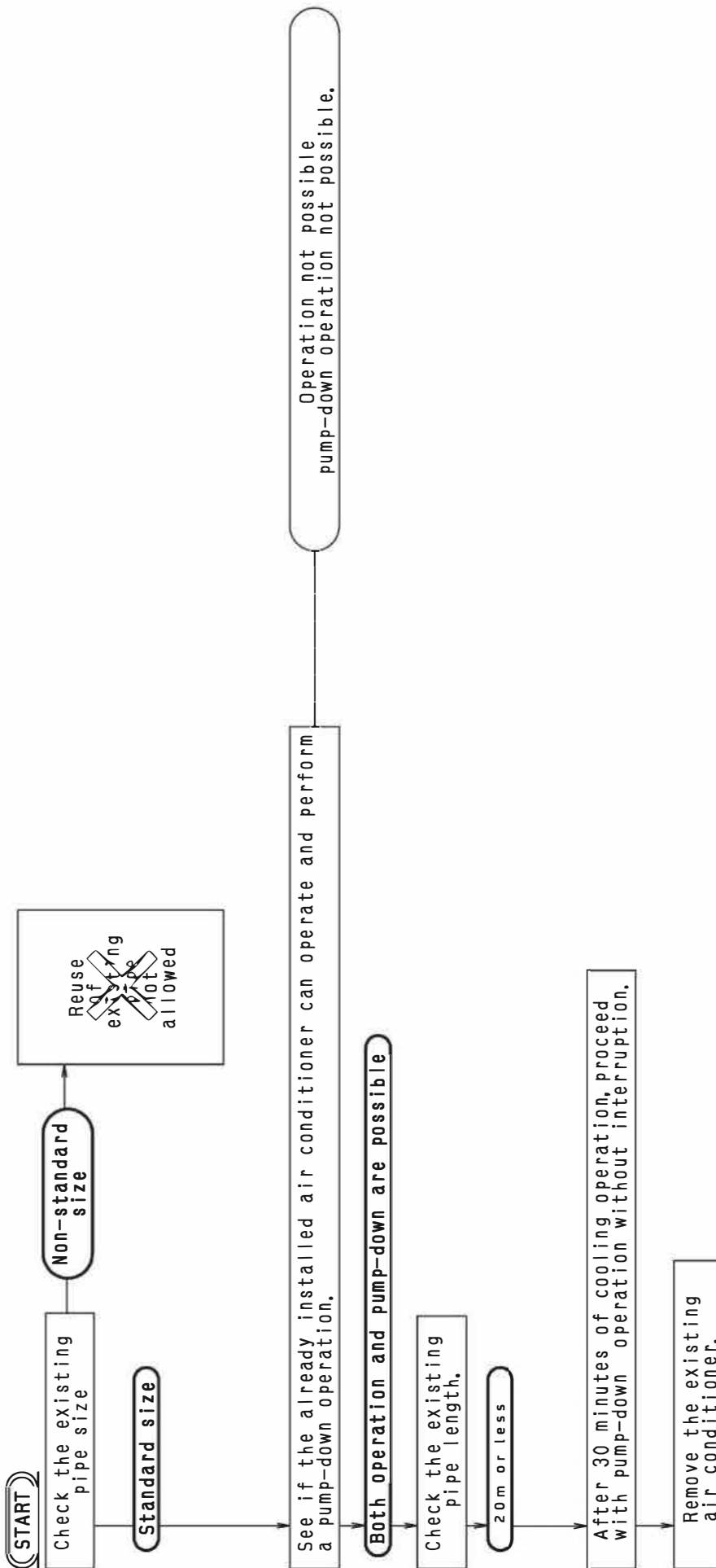

(Note)

- ① Clean the pipe if refrigerant leakage and unit has not service port on gas-liquid stop valve.
- ② If indoor unit equipped with EV valve, open that valve before recovery refrigerant.
- ③ Maximum pipe length as per specified on next page

## PRECAUTIONS ON REFRIGERANT PIPING

- Clean pipe if existing air conditioner is [gas, oil heat pump type].
- Clean pipe if used compressor oil in existing air conditioner is other than [SUNISO, MS, HAB, Barrel freeze, JOMO, Ethereal oil, Ester oil].
- Clean pipe if existing indoor and outdoor unit is disconnected.
- Change new pipe if refrigerant leakage or it should adding refrigerant.
- Change new heat insulation if existing part is peeling off.

# 14.1 REFRIGERANT RECOVERY

## [Working procedure]

### 1.Recovery retaining oil in existing gas pipe Approx. 1 min

Close gas stop valve (liquid stop valve : open) and recovery refrigerant from gas stop valve port.(Fig.1)

### 2.Recovery retaining oil in existing liquid pipe Approx. 1 min

Recovery refrigerant from liquid stop valve port.(Fig.2)

### 3.Recovery refrigerant in outdoor unit Approx 2-3 min

Recovery refrigerant from outdoor unit refrigerant recovery port \*1. (Fig.3)

NOTE \* 1 Can be omit this procedure if there has no refrigerant recovery port.

### 4.Recovery refrigerant in accordance with Fluorocarbons Recovery and Destruction Law

If refrigerant recovery port \*2 pressure became lower than gas stop valve port pressure, refrigerant will recover at the simultaneous from the gas stop valve port, open gas stop valve (Fig.3- ①) gradually to avoid from pressure rising rapidly. (Fig.3- ②)

NOTE \* 2 Recovery refrigerant from liquid valve port and stop valve port simultaneous if there has no refrigerant recovery port.

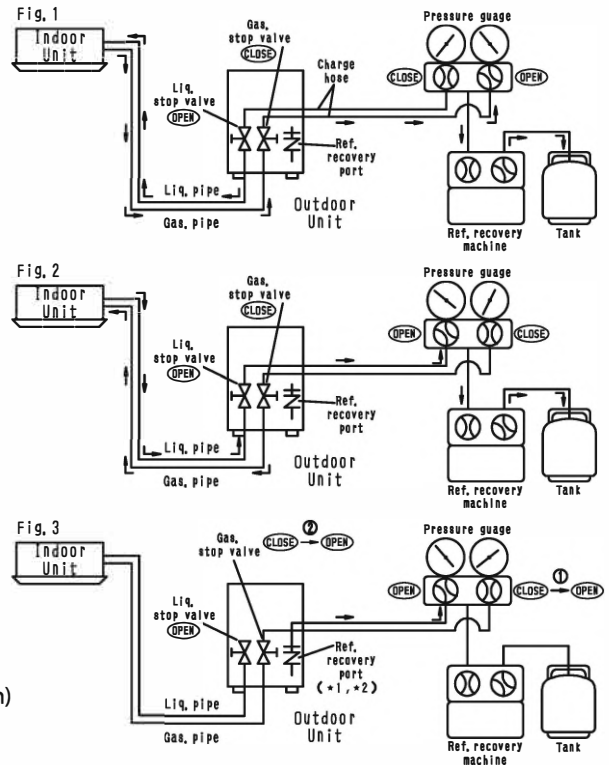

Retaining oil recovery amount improved approx. 5 times from regular refrigerant recovery method

(pipe length, height difference, pipe path etc. is difference by installation condition)

## ABOUT FLARE PROCESSING

● Flare connection area of existed piping will cause processing deterioration, make sure to do newly re-processing.

■ Flare processing [Unit : mm]

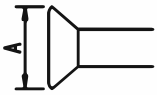

Piping outside diameter	A(+0,-0.4)+
	For R32
Ø6.35	9
Ø9.5	13
Ø12.7	16.2
Ø15.9	19.7

● Please use flare nut which attached with product (Do not use existed flare nut)

■ Flare nut [Unit : mm]



Piping outside diameter	B(+0,-0.4)+
	For R32
Ø6.35	17
Ø9.5	22
Ø12.7	26
Ø15.9	29

## REFRIGERANT PIPE SIZE TABLE

Outdoor Unit	Pipe size (mm)	Pipe Length		Height difference	Design pressure (High pressure)
RZMFQ50	6.35/12.7	Standard pipe length	7.5m	Max 20m	4.17 MPa
RZMFQ71	6.35/15.9	Max pipe length	20m		
		Charge less length	10m		
RZMFQ90, 100, 125, 140	9.52/15.9	Standard pipe length	7.5m	Max 30m	4.17 MPa
		Max pipe length	30m		
		Charge less length	15m		

■ Refer to the installation manual for details other than those mentioned above table such as additional refrigerant charge amount.

■ Standard pipe (R32)

Pipe size (mm)	Ø6.35	Ø9.5	Ø12.7	Ø15.9
Thickness (mm)	t 0.8	t 0.8	t 1.0	t 1.0

---

**SPLIT SYSTEM****Air Conditioner**

---

**MODELS****(Ceiling-mounted Duct type)****FDMFQ50AV16****FDMFQ71AV16****FDMFQ90AV16****FDMFQ100AV16****FDMFQ125AV16****FDMFQ140AV16**



Thank you for purchasing this product unit. Carefully read this operation manual to ensure proper operation.

After reading the manual, file it away for future reference.

Furthermore, make certain that this operation manual is handed to a new user when he/she takes over the operation.

As this operation manual is dedicated for the indoor unit, refer to also the operation manuals attached to the outdoor unit and the remote controller.

## CONTENTS

1.SAFETY PRECAUTIONS .....	61
2.WHAT TO DO BEFORE OPERATION .....	64
3.OPERATION RANGE.....	65
4.INSTALLATION SITE.....	66
5.OPERATION PROCEDURE.....	66
6.OPERATION CHARACTERISTICS.....	66
7.OPTIMUM OPERATION.....	67
8. MAINTENANCE (FOR SERVICE PERSONNEL).....	68
9. NOT MALFUNCTION OF THE AIR CONDITIONER .....	69
10.TROUBLESHOOTING .....	70

## 1- SAFETY PRECAUTIONS



**Read the precautions in this manual carefully before operating the unit.**



**This appliance is filled with R32.**

To gain full advantage of the air conditioner's functions and to avoid malfunction due to mishandling, please read this operation manual carefully before use.

Read the precautions thoroughly to avoid misuse of the equipment.

This product comes under the term "appliances not accessible to the general public".

**This appliance is intended to be used by expert or trained users in shops, in light industry and on farms, or for commercial use by lay persons.**

**This appliance can be used by children aged from 8 years and above and persons with reduced physical, sensory or mental capabilities or lack of experience and knowledge if they have been given supervision or instruction concerning use of the appliance in a safe way and understand the hazards involved. Children shall not play with the appliance. Cleaning and user maintenance shall only be done by persons described in manual.**

**The appliance is not intended for use by unattended young children or persons who are incompetent to operate air conditioners.** It may result in injury or electric shocks.

- **The precautions described herein are classified as WARNING and CAUTION. They both contain important information regarding safety.**

**Be sure to observe all precautions without fail.**

- **There are two kinds of safety precaution and tips listed in the following.**



**WARNING** ..... Indicates a potentially hazardous situation which, if not avoided, could result in death or serious injury.



**CAUTION** ..... Indicates a potentially hazardous situation which, if not avoided, may result in minor or moderate injury. It may also be used to alert against unsafe practices.

- **After reading, keep this manual in a convenient place so that you can refer to it whenever necessary. If the equipment is transferred to a new user, be sure also to hand over the manual.**

### ■ DISPOSAL REQUIREMENTS



#### Disposal requirements

Your air conditioning product is marked with this symbol. This means that electrical and electronic products shall not be mixed with unsorted household waste.

Do not try to dismantle the system yourself: the dismantling of the air conditioning system, treatment of the refrigerant, of oil and of other parts must be done by a qualified installer in accordance with relevant local and national legislation.

Air conditioners must be treated at a specialized treatment facility for reuse, recycling and recovery. By ensuring this product is disposed of correctly, you will help to prevent potential negative consequences for the environment and human health. Please contact the installer or local authority for more information.

Batteries must be removed from the remote controller and disposed of separately in accordance with relevant local and national legislation.

**⚠ WARNING**

**Do not use means to accelerate the defrosting process or to clean, other than those recommended by the manufacturer.**

**The appliance must be stored in a room without continuously operating ignition sources (for example: open flames, an operating gas appliance or an operating electric heater).**

**Do not pierce or burn.**

**Be aware that refrigerants may not contain an odour.**

**Floor area required for installation of the equipment, refer to the installation manual of the outdoor unit.**

**Do not place burners or heaters in places exposed to the airflow from the unit as this may impair combustion of the burner or heater.**

**When the air conditioner is malfunctioning (giving off a burning odor, etc.), turn off the power to the air conditioner and contact your local dealer.**

Continued operation under such circumstances may result in a failure, electric shocks or a fire .

**Consult your local dealer regarding modification, repair and maintenance of the air conditioner.**

Improper workmanship may result in water leakage, electric shocks or a fire .

**Be sure to use fuses with the correct ampere reading.**

Do not use improper fuses, copper or other wiring as a substitute, as this may result in electric shocks, a fire, injury or damage to the air conditioner.

**Consult your local dealer if the air conditioner submerges owing to a natural disaster, such as a flood or typhoon.**

Do not operate the air conditioner in that case, or otherwise a malfunction, electric shocks, or a fire may result.

**Start or stop the air conditioner with the remote controller. Never use the power circuit breaker for this purpose.**

Otherwise, it may cause a fire or water leakage. Furthermore, if an automatic restart control is provided against power failure and the power is recovered, the fan will rotate suddenly and may cause injury.

**Do not use the air conditioner in the atmosphere contaminated with oil vapor, such as cooking oil or machine oil vapor.**

Oil vapor may cause crack damage to the air conditioner, electric shocks, or a fire .

**Do not use flammable materials (e.g., hairspray or insecticide) near the air conditioner.**

**Do not clean the air conditioner with organic solvents such as paint thinner.**

The use of organic solvents may cause crack damage to the air conditioner, electric shocks, or a fire .

**Do not use the air conditioner in places with excessive oily smoke, such as cooking rooms, or in places with flammable gas, corrosive gas, or metal dust.**

Using the air conditioner in such places may cause a fire or air conditioner failures.

**Beware of a fire in case of refrigerant leakage.**

If the air conditioner is not operating correctly, i.e. not generating cool or warm air, refrigerant leakage could be the cause. Consult your local dealer for assistance. The refrigerant used for the air conditioner is safe and normally does not leak. However, if the refrigerant leaks and gets in contact with a naked burner, heater or cooker, it may generate hazardous compounds. Turn off the air conditioner and call your local dealer. Turn on the air conditioner after the qualified service person makes sure to confirm that the leakage is repaired.

**Do not place objects, including rods, your fingers, etc., in the air inlet or outlet.**

Injury may result due to contact with the air conditioner's highspeed fan blades.

**Consult your local dealer regarding cleaning the inside of the air conditioner.**

Improper cleaning may cause breakage of plastic parts, water leakage and other damage as well as electric shocks.

**Be aware that prolonged, direct exposure to cool or warm air from the air conditioner, or to air that is too cool or too warm can be harmful to your physical condition and health.**

**Consult your local dealer about installation work.**

Doing the work yourself may result in water leakage, electric shocks or a fire .

**Contact professional personnel about attachment of accessories and be sure to use only accessories specified by the manufacturer.**

If a defect results from your own workmanship, it may result in water leakage, electric shocks or a fire .

**Consult your local dealer regarding relocation and reinstallation of the air conditioner.**

Improper installation work may result in leakage, electric shocks or a fire.

**Be sure to earth the air conditioner.**

Do not earth the air conditioner to a utility piping, lightning conductor or telephone earth lead. Imperfect earthing may result in electric shocks or a fire.

A high surge current from lightning or other sources may cause damage to the air conditioner.

**Be sure to install an earth leakage breaker.**

Failure to install an earth leakage breaker may result in electric shocks or a fire.

**Be sure to use a dedicated power supply for the air conditioner.**

The use of any other power supply may cause heat generation, a fire, or air conditioner failures

**Consult your local dealer regarding what to do in case of refrigerant leakage.**

When the air conditioner is installed in a small room, it is necessary to take proper measures so that the amount of any leaked refrigerant does not exceed the concentration limit in the event of a leakage. Otherwise, this may lead to an accident due to oxygen depletion.

---

 **CAUTION**

**Children should be watched so that they do not play with the indoor unit or its remote controller.**

Accidental operation by a child may result in injury or electric shocks.

**Do not allow a child to mount on the outdoor unit or avoid placing any object on it.**

Falling or tumbling may result in injury.

**Do not let children play on or around the outdoor unit.**

If they touch the unit carelessly, injury may be caused.

**Be sure that children, plants or animals are not exposed directly to airflow from the indoor unit, as adverse effects may ensue.**

**Do not place flammable sprays or operate spray containers near the air conditioner as this may result in a fire.**

**Do not wash the air conditioner or the remote controller with water, as this may result in electric shocks or fire.**

**Do not place water containers (flower vases, etc.) on the indoor unit, as this may result in electric shocks or a fire.**

**Do not put flammable containers, such as spray cans, within 1 m from the air outlet.**

The containers may explode because the warm air from the indoor or outdoor unit will affect them.

**Turn off the main power switch when the air conditioner is not to be used for prolonged periods.**

When the main power switch is left on, some electrical power (watts) is still consumed even if the air conditioner is not operating. Therefore, switch off the main power switch to save energy. When resuming operation, to ensure smooth running, turn on the main power switch 6 hours before operating the air conditioner again.

**Do not place objects in direct proximity of the outdoor unit and do not let leaves and other debris accumulate around the unit.**

Leaves are a hotbed for small animals which can enter the unit. Once in the unit, such animals can cause malfunctions, smoke or a fire when making contact with electrical parts.

**Before cleaning, be sure to stop the air conditioner operation, turn the power circuit breaker off.**

Otherwise, an electric shocks and injury may result.

**To avoid electric shocks, do not operate with wet hands.**

**Never touch the internal parts of the remote controller.**

Touching certain internal parts will cause electric shocks and damage to the remote controller. Consult your local dealer about checking and adjustment of internal parts.

**To avoid oxygen deficiency, ensure that the room is adequately ventilated if equipment such as a burner is used together with the air conditioner.**

**Do not leave the remote controller wherever there is a risk of wetting.**

If water gets into the remote controller there is a risk of electrical leakage and damage to electronic components.

**Watch your steps at the time of air filter cleaning or inspection.**

High-place work is required, to which utmost attention must be paid.

If the scaffold is unstable, you may fall or topple down, thus causing injury.

**Do not remove the outdoor unit's outlet side grille.**

The grille protects against the unit's high speed fan, which may cause injury.

**To avoid injury, do not touch the air inlet or aluminum fins of the air conditioner.**

**Do not place objects that are susceptible to moisture directly beneath the indoor or outdoor units.**

Under certain conditions, condensation on the unit or refrigerant piping, air filter dirt or drain blockage may cause dripping, resulting in fouling or failure of the object concerned.

**Do not place heaters directly below the indoor unit, as resulting heat can cause deformation.**

**Do not place appliances that produce naked flames in places exposed to the airflow from the air conditioner as this may impair combustion of the burner.**

**Do not block air inlets nor outlets.**

Impaired airflow may result in insufficient performance or trouble.

**Do not use the air conditioner for purposes other than those for which it is intended.**

Do not use the air conditioner for cooling precision instruments, food, plants, animals or works of art as this may adversely affect the performance, quality and/or longevity of the object concerned.

**Do not install the air conditioner at any place where there is a danger of flammable gas leakage.**

In the event of a gas leakage, build-up of gas near the air conditioner may result in a fire .

**Carry out drain piping properly to ensure complete drainage.**

If drain piping is not carried out properly, drain will not flow out. Then, dirt and debris may be accumulated in the drain piping and may cause water leakage. If it occurs, stop the air conditioner and call your local dealer for assistance.

**After prolonged use, check the unit stand and its mounts for damage.**

If left in a damaged condition, the unit may fall and cause injury.

**Do not sit or place objects on the outdoor unit.**

Falling yourself or falling objects could cause injury.

**Arrange the drain hose to ensure smooth drainage.**

Imperfect drainage may cause wetting of the building, furniture etc.

**Ensure that the remote controller is not exposed to direct sunlight.**

This will cause discoloration of the LCD display with resulting loss of readability.

**Do not wipe the controller panel with benzene or other organic solvent.**

This will cause discoloration and/or peeling.

If the panel needs cleaning, use a damp cloth with some water-diluted neutral detergent.

Wipe with a dry cloth afterwards.

**Never operate remote controller buttons with hard, pointed objects.**

**Do not pull or twist the remote controller cord.**

This may cause malfunctioning.

**Do not operate the air conditioner when using a room fumigation type insecticide.**

Fumigation chemicals deposited in the unit could endanger the health of those who are hypersensitive to such chemicals.

**Take care of scaffolding and exercise caution when working high above ground level.**

**Do not operate with the control panel lid open.**

If water gets inside the panel, it may result in equipment failure or electric shock.

## 2. WHAT TO DO BEFORE OPERATION

This operation manual is for the following system with standard control. Before initiating operation, contact your local dealer for the operation that corresponds to your system

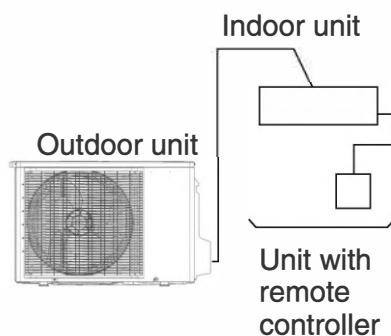

- **Cooling only type**

This system provides COOLING, PROGRAM DRY and FAN OPERATION modes.



## PRECAUTIONS REMOTE CONTROLLERS CONTROL SYSTEM

This system provides two other control systems beside individual control (one remote controller controls one indoor unit) system. Confirm the following if your unit is one of the following control system type.

### NOTE

- Read the operation manual attached to the remote controller you are using.

When using a wireless remote controller, refer to the operation manual attached to the wireless remote controller kit.

If your installation has a customized control system, ask your local dealer for the operation that corresponds to your system.

## Names and functions of parts

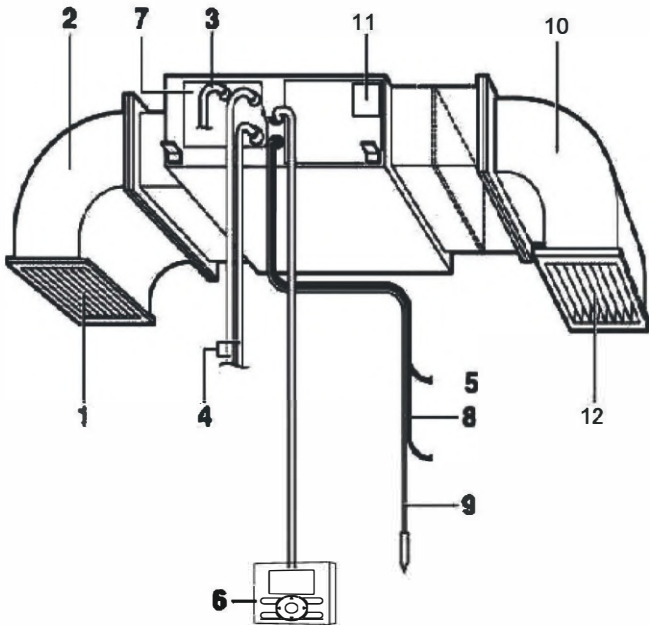

1	Air outlet (Field supply)
2	Exhaust duct (Field supply)
3	Drain pipe
4	Refrigerant piping
5	Wiring between indoor and outdoor unit
6	Remote controller (Sold separately)
7	Drain discharge device (built-in) Discharges indoor moisture removed during cool-ing operation.
8	Power line
9	Grounding wire This wire releases electricity from the indoor unit to the ground in order to prevent electric shock or fire.
10	Suction duct (Field supply)
11	Machine nameplate The nameplate is imprinted with the machine name and specifications.
12	Suction grille (Field supply)

## 3. OPERATION RANGE

If the temperature or the humidity is beyond the following conditions, safety devices may work and the air conditioner may not operate, or sometimes, water may drop from the indoor unit.

### COOLING

OUTDOOR UNIT	INDOOR		OUTDOOR TEMPERATURE		
	TEMPERATURE	HUMIDITY			
RZMFQ-AV16	D B	19 to 35	80% or below	D B	19 to 50
	W B	14 to 24			

DB: Dry bulb temperature (°C)

WB: Wet bulb temperature (°C)

## 4. INSTALLATION SITE

### Regarding places for installation

- **Is the air conditioner installed at a well-ventilated place where there are no obstacles around?**
- **Do not use the air conditioner in the following places.**
  - a. Filled with much mineral oil such as cutting oil
  - b. Where there is much salt such as a beach area
  - c. Where sulfured gas exists such as a hot-spring resort
  - d. Where there are considerable voltage fluctuation such as a factory or plant
  - e. Vehicles and vessels
  - f. Where there is much spray of oil and vapor such as a cookery, etc.
  - g. Where there are machines generating electromagnetic waves
  - h. Filled with acid and/or alkaline steam or vapor
- **Is a snow protection measure taken?**  
For details, consult your local dealer about snow protection hoods, etc.

### Regarding wiring

- **All wiring must be performed by a qualified personnel.**  
To do wiring, ask your local dealer. Never do it by yourself.
- **Make sure that a separate power supply circuit is provided for this air conditioner and that all electrical work is carried out by qualified personnel according to local laws and regulations.**

### Pay attention to running noises, too

- **Are the following places selected?**
  - a. A place that can sufficiently withstand the mass of the air conditioner with less running noises and vibrations.
  - b. A place where the hot wind discharged from the air outlet of the outdoor unit and the running noises do not cause a nuisance to neighbours.
- **Are you sure that there are no obstacles near the air outlet of the outdoor unit?**  
Such obstacles may result in declined performance and increased running noises.
- **If abnormal noises occur in use, stop the operation of the air conditioner, consult your local dealer.**

### Regarding drainage of drain piping

- **Is the drain piping carried out properly to ensure complete drainage?**

If drain piping is not carried out properly, dirt and debris may be accumulated in the drain piping and cause water leakage. If it occurs, stop the air conditioner and consult with your local dealer for assistance.

### System relocation

- **Consult your Daikin dealer about remodelling and relocation.**

## 5. OPERATION PROCEDURE

- Operating procedure varies with heat pump type and cooling only type. Contact your local dealer to confirm your system type.
- To protect the air conditioner, turn on the main power switch 6 hours before operation.
- Do not shut off the power supply during seasonal use of the air conditioner.  
This is required in order to activate the air conditioner smoothly.
- If the main power supply is turned off during operation, operation will restart automatically after the power turns back on again.

**Read the operation manual attached to the remote controller.**

## 6. OPERATION CHARACTERISTICS

### ■ CHARACTERISTICS OF THE COOLING OPERATION (COOLING OPERATION AND AUTOMATIC COOLING OPERATION)

- If the COOLING OPERATION is used when the indoor temperature is low, frost forms on the heat exchanger of the indoor unit. This can decrease the cooling capacity. In this case, the air conditioner automatically switches to the DEFROST OPERATION for a while.  
During the DEFROST OPERATION, the low fan speed is used to prevent the discharge of melt water. (The remote controller displays the fan speed that is set.)
- When the outdoor temperature is high, it takes some time until the indoor temperature reaches the set temperature.

## ■ CHARACTERISTICS OF THE PROGRAM DRY OPERATION

- This operation lowers the humidity without lowering the indoor temperature. The indoor temperature when the operation button is pressed will be the set temperature. At this time, the fan speed and temperature are set automatically, so the remote controller does not display the fan speed and set temperature.

To efficiently lower the indoor temperature and humidity, first use the COOLING OPERATION to lower the indoor temperature, and then use the PROGRAM DRY OPERATION. When the indoor temperature is lowered, airflow from the air conditioner may stop.

- If the PROGRAM DRY OPERATION is used when the indoor temperature is low, frost forms the heat exchanger of the indoor unit. In this case, the air conditioner automatically switches to the DEFROST OPERATION for a while. The low fan speed or a gentle wind is used to prevent the discharge of melt water.

## 7. OPTIMUM OPERATION

Observe the following precautions to ensure the air conditioner operates.

- Prevent direct sunlight from the window by using curtains or blinds during the COOLING OPERATION.
- Keep doors and windows closed. If the doors and windows remain open, room air will flow out and decrease the effect of cooling and heating.
- Never place objects near the air inlet and the air outlet of the air conditioner. It may decrease the effect or stop the operation.
- Set the airflow of the air discharge grille horizontally not to obstruct the wind. Otherwise, the wind will not come out and a failure may result.
- Adjust the room temperature properly for a comfortable environment. Avoid excessive heating or cooling. Not doing so wastes electricity.
- When the display shows “” or “Time to clean filter”, ask a qualified service person to clean the filters.  
(Refer to **8. MAINTENANCE** page 68.)  
Operating the indoor unit with stained air filter may decrease capacity or cause malfunction.
- Install TVs, radios, and stereos 1 m or more away from the indoor unit and remote controller. Images may become fuzzy and noise may be generated.  
Turnoff the power circuit breaker when it is not in use for along period. When the power circuit breaker is turned on, small amount of power is consumed even if the air conditioner is not in operation. (\*1)  
Turnoff the power circuit breaker for saving energy. When reoperating, turnon the power circuit breaker 6hours before operation for smooth running.  
(Refer to **8. MAINTENANCE** page 68.) (\*2)  
\*1 The consumed power while the outdoor unit is not in operation depends on the model.  
\*2 The setting before the power circuit breaker is cut off is stored. (The timer setting is cleared.)
- Use the TIMER OPERATION effectively. It takes some time until the indoor temperature reaches the set temperature. It is advisable to start operation in advance using the TIMER OPERATION.

## 8. MAINTENANCE (FOR SERVICE PERSONNEL)

### ONLY A QUALIFIED SERVICE PERSON IS ALLOWED TO PERFORM MAINTENANCE

#### WARNING

- Do not use flammable gas (such as hair sprays and insecticides) near the air conditioner.
- Do not wipe the air conditioner with benzene or thinner.  
It may cause cracks, electric shocks or a fire.

#### CAUTION

- Do not wash the air conditioner with water. It may cause electric shocks or a fire due to leakage.
- Make sure to turn off the air conditioner when taking care of the air conditioner and disconnect the power supply breaker. Unless the power supply is disconnected, it may cause electric shocks and injuries.
- When working at a high place, give caution to your footing.  
If the scaffold is unstable, it may cause injuries due to fall and stumbling.

### HOW TO CLEAN THE AIR FILTER

When the remote controller indicates “” or “Time to clean filter” clean the air filter.

- It indicates after running for a certain time.

#### NOTE

- You may change the time of indication “” or “Time to clean filter”  
If the indoor unit is used in a space where the air is too contaminated, ask your local dealer for solution.

Contamination	Time until indication is displayed
Normal	200 hours (equivalent to 1 month)
More contaminated	100 hours (equivalent to 2 weeks)

- If it becomes difficult to remove contamination from the air filter, replace the air filter.  
(Air filter for replacement is an optional accessory)

Increase the frequency of cleaning if the unit is installed in a room where the air is extremely contaminated.

#### NOTE

- Do not remove the air filter except when cleaning. Unnecessary handling may damage the filter. (This product is not provided with an air filter as a standard accessory.)
- Do not attach objects other than the genuine air filter (e.g., kitchen paper) to the air inlet. Otherwise, the performance of the air conditioner will be degraded, and icing or water leakage may result.
- This product is a ceiling mounted duct type air conditioner.

#### Installing under roof

If the air filter (optional parts) is used, request a special contractor for the cleaning of the air filter.

After completing cleaning and installing an air filter, turn off the indication of “” or “AIR FILTER CLEANING TIME” on the remote controller.

- Press the FILTER SIGN RESET button.
- The indication can be turned off while the unit is either operating or stopped.

### HOW TO CLEAN AIR OUTLET, OUTSIDE PANELS AND REMOTE CONTROLLER

1. Clean with soft cloth.
2. When it is difficult to remove stains, use water or neutral detergent.

#### NOTE

- Do not wash the suction grille with water of 50°C or higher.  
It may cause discoloration and deformation.
- When drying the suction grille, do not heat it with fire. It may cause burning.
- Do not use substances such as gasoline, benzene, thinner, polishing powder and liquid insecticide sold in the market.  
It may cause discoloration and deformation.

## WHAT TO DO WHEN START UP AFTER A LONG STOP

### Confirm the following

- Check that the air inlet and outlet of indoor and outdoor unit are not blocked.  
Remove any obstacle.  
Obstacles decrease the fan speed, and cause performance decrease and breakage of the devices.

### Clean the air filter

- After cleaning the air filter, make sure to attach it.
- For information on how to clean an optional sold air filter, refer to the user's manual attached to the air filter.
- Turn off the indication “” or “Time to clean filter” displayed on the remote controller after turning on the power.  
The indication can be turned off whether in operation or at stop.  
For details, refer to the operation manual attached to the remote controller.

### Turn on the power circuit breaker at least 6 hours before operation.

- This is required in order to activate the air conditioner smoothly, and to protect air conditioner.
- The display on the remote controller will be shown when the power circuit breaker is turned on.

## WHAT TO DO TO STOP THE AIR CONDITIONER FOR A LONG PERIOD

### Turn on FAN OPERATION for a half day on the fine day and dry the indoor unit.

- This can prevent the causes of mould.

### Turn off the power circuit breaker.

- During the power circuit breaker is turned on, some watts of electricity is being used even if the air conditioner is not operating.  
Turn off the power circuit breaker for saving energy.
- The display on the remote controller will vanish when the power circuit breaker is turned off.

### Clean the air filter and outside panel

- Be sure to replace the air filter to its original place after cleaning.  
For information on how to install, remove, or clean an optional sold air filter, refer to the user's manual attached to the air filter.

### NOTE

The inside of the air conditioner may become contaminated after several seasons of use, potentially causing performance degradation and water leakage.

Ask your local dealer for details on cleaning the inside of the indoor unit. This operation requires a qualified service person.

## 9. NOT MALFUNCTION OF THE AIR CONDITIONER

The following symptoms do not indicate air conditioner malfunction

### 1. THE AIR CONDITIONER DOES NOT OPERATE

- The air conditioner does not restart immediately after the ON/OFF button is pressed.
- The air conditioner does not restart immediately when TEMPERATURE SETTING button is returned to the former position after pushing the button.  
If the OPERATION lamp lights, the air conditioner is in normal condition.  
It does not restart immediately because a safety device operates to prevent overload of the air conditioner.  
After approx. 3 minutes, the air conditioner will turn on again automatically.
- The air conditioner does not start when the display shows “” and it flashes for few seconds after pressing an operation button.

Flashes on the display indicates that the air conditioner cannot be controlled by the remote controller.

- The outdoor unit stops.

This is because the indoor temperature has reached the set temperature.

The indoor unit is in the FAN OPERATION, COOLING OPERATION (AUTOMATIC COOLING OPERATION):

Lower the set temperature.

The operation starts after a while when the air conditioner is in normal condition.

### 2. THE OPERATION SOMETIMES STOPS

- The remote controller displays “U4” and “U5”, and the operation stops. However, it will restart in a few minutes.

This is because communication between the indoor and outdoor units or indoor units and remote controllers is shut off and stops the operation due to noise caused by devices other than the air conditioner.

When the electrical noise decreases, the air conditioner automatically restarts.

### 3. THE FAN SPEED IS DIFFERENT FROM THE SETTING

- **Pressing the fan speed control button does not change the fan speed.**

During the COOLING OPERATION, the low fan speed or a gentle wind is used to prevent the discharge of melt water.

After a while, the fan speed can be changed. (The fan speed cannot be set for the PROGRAM DRY OPERATION.)

### 4. WHITE MIST COMES OUT OF THE AIR CONDITIONER

- **When humidity is high during the COOLING OPERATION (In oily or dusty places)**

If the inside of an indoor unit is extremely contaminated, the temperature distribution inside a room becomes uneven. It is necessary to clean the inside of the indoor unit.

Ask your local dealer for details on cleaning the indoor unit.

This cleaning requires a qualified service person.

Check the usage environment.

### 5. NOISE OF AIR CONDITIONERS

- **A low continuous flow “Shuh” sound which is heard when the air conditioner is in the COOLING or DEFROST OPERATION or a trickling sound which is heard when the air conditioner is in the DEFROST OPERATION.**

This is the sound of refrigerant gas flowing through both indoor and outdoor units.

- **A “Pishi-pishi” squeaking sound is heard when the air conditioner is in operation or after the stop of operation.**

Expansion and contraction of resin parts caused by temperature change makes this noise.

### 6. DUST FROM THE INDOOR UNITS

- **Dust may blow out from the unit after starting operation from long resting time.**

Dust absorbed by the unit blows out.

### 7. THE INDOOR UNITS GIVE OFF ODORS

- **During operation**

The unit absorbs the smell of rooms, furniture, cigarettes, etc., and then emits them.

If odor is a concern, you can set to zero fan speed when the indoor temperature reaches the set temperature.

For details, contact your local dealer.

### 8. THE AIR CONDITIONER DOES NOT COOL EFFECTIVELY

- **The air conditioner is operating in the PROGRAM DRY OPERATION.**

This is because program dry mode operates so that the indoor temperature decreases as little as possible.

Lower the indoor temperature using the COOLING OPERATION, and then use the PROGRAM DRY OPERATION.

(Refer to **CHARACTERISTICS OF THE PROGRAM DRY OPERATION** on page 67.)

- **Read through characteristics of the COOLING OPERATION, and characteristics of the PROGRAM DRY OPERATION on page 66-67.**

## 10. TROUBLESHOOTING

**Please check before requesting a service.**

### 1. If the air conditioner does not operate at all.

- Check if fuse has blown.  
Turn off the power supply.
- Check if the power circuit breaker is blown.  
If the tab of power circuit breaker is in the OFF position, turn the power on with the power circuit breaker switch.  
If the tab of power circuit breaker is in the trip position do not turn the power on with the power circuit breaker switch.  
Contact your local dealer.



Power circuit breaker  
(Earth leakage breaker)

- Check if there is a power failure.  
Wait until power is restored. If power failure occurs during operation, the air conditioner automatically restarts immediately after the power supply recovers.

## 2. If the air conditioner stops after operating the air conditioner.

- Check if the air inlet or outlet of outdoor or indoor unit is blocked by obstacles.  
Remove the obstacle and make it well-ventilated.
- Check if the air filter is clogged.  
Ask a qualified service person to clean the air filters.  
A decrease in the airflow volume of the air conditioner will result and the performance of the air conditioner will be degraded and power consumption will increase if the air filter is clogged with dust or dirt.  
In addition, this may cause dew condensation at the air outlet.  
(Refer to **8. MAINTENANCE** on page 68.)

## 3. The air conditioner operates but it does not sufficiently cool.

- Check if the air inlet or outlet of outdoor or indoor unit is blocked by obstacles.  
Remove the obstacle and make it well-ventilated.  
Obstacles decrease the fan speed, and cause performance decrease and breakage when discharged air is suctioned.  
They cause a waste of electricity, and that may stop the devices.
- Check if the air filter is clogged.  
Ask a qualified service person to clean the air filters.  
A decrease in the airflow volume of the air conditioner will result and the performance of the air conditioner will be degraded and power consumption will increase if the air filter is clogged with dust or dirt.  
In addition, this may cause dew condensation at the air outlet.  
(Refer to **8. MAINTENANCE** on page 68.)
- Check if the set temperature is not proper.  
Set to an appropriate temperature and fan speed.
- Check if the FAN SPEED button is set to LOW SPEED.  
Set to an appropriate temperature and fan speed.
- Check if the doors or the windows are open.  
Shut doors or windows to prevent wind from coming in.
- Check if direct sunlight enters the room (when cooling).  
Use curtains or blinds.
- When there are too many inhabitants in the room (when cooling).
- Check if the heat source of the room is excessive (when cooling).

## 4. Operation was performed or stopped although the ON/OFF button was not pressed.

- Are you sure that the ON/OFF timer operation is not used?  
Turn off the ON/OFF timer.  
Please refer to operation manual attached to the remote controller.
- Are you sure that any remote control device is not connected?  
Contact the central control room that directed the stop.  
Contact the central control room that directed the stop.  
If the problem is not solved after checking the above points, please do not try to repair it yourself.  
In such cases, always ask your local dealer.  
At this time, please tell the symptom and model name (written on the model name plate).

### If one of the following malfunctions occurs, take the measures shown below and contact your local dealer.

The air conditioner must be repaired by a qualified service person.

### **WARNING**

#### **When the air conditioner is malfunctioning (giving off a burning odor, etc.), turn off power to the air conditioner and contact your local dealer.**

Continued operation under such circumstances may result in a failure, electric shocks or fire .  
Contact your local dealer.

- If a safety device such as a fuse, a power circuit breaker or an earth leakage breaker frequently actuates;  
**Measure:** Do not turn on the main power switch.
- If the ON/OFF switch does not properly work;  
**Measure:** Turn off the main power switch.
- If water leaks from the indoor unit.  
**Measure:** Stop the operation.
- If a malfunction occurs, either one of the following messages will appear on the Basic screen on the wired remote controller during operation.  
“Error: Push Menu button.”  
(\* The Operation lamp will blink.)  
“Warning: Push Menu button.”  
(\* The Operation lamp will not blink.)
- Press Menu/Enter button.  
The Malfunction (Error) code blinks.  
For more information, refer to the operation manual attached to the remote controller.  
**Measure:** Notify your local dealer and inform malfunction code of the display.

**PROTECT THE ENVIRONMENT FROM E-WASTE ( GUIDELINES)**

Meaning of E-waste under E-Waste (Management) Rules,2022 (E-waste Rules)  
-Waste electrical and electronic equipment, whole or in part of reject from their manufacturing and repair process, which are intended to be discarded.

Our product is RoHS compliant.



**Don't dump Electrical and Electronic Products in Garbage Bins**

**DO'S & DONT'S**

<b>DO'S</b>	
Run and maintain the air conditioner as per the instructions given in the operation / instruction manual	✓
Ensure that an authorised person repairs your air conditioner	✓
Call our local authorised dealer or our toll free number to dispose your air conditioner	✓
Contact an authorised dealer in case of installation or de-installation	✓
Consult our local authorised dealer or our toll free number on the life span of the air conditioner	✓
<b>DONT'S</b>	
Do not try to repair your air conditioner on your own	✗
Do not sell or dispose your air conditioner or parts to an unauthorised Kabbadi wala / Scrap Dealer / Ragpickers	✗
Do not dismantle your air conditioner on your own	✗
Do not get your air conditioner or any parts repaired by an unauthorised person	✗
Do not dispose off the E-waste in landfills	✗
Do not use the air conditioner as furniture after its use	✗

**Customer Contact Center : 011-4031 9300/1860-180-3900**  
**For further information visit us at [www.daikinindia.com](http://www.daikinindia.com)**



**DAIKIN AIRCONDITIONING INDIA PVT. LTD.**

12th Floor, Building No. 9, Tower A,  
DLF Cyber City, DLF Phase - III  
Gurgaon - 122002, Haryana (India)  
Tel : +91-124-4555444  
Fax: +91-124-4555333