

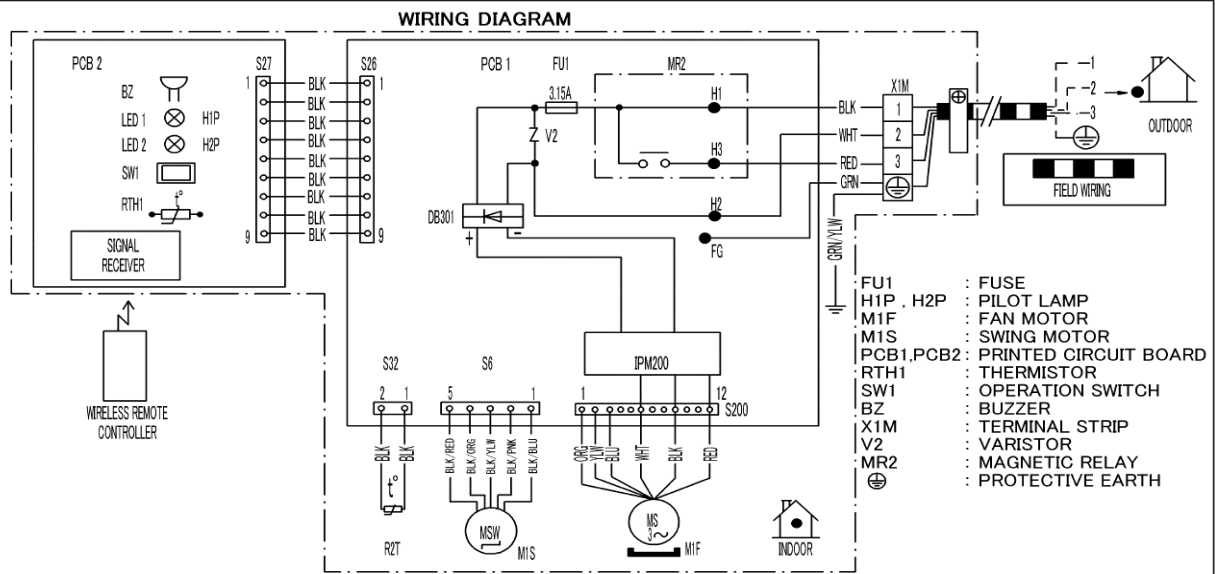

BMSN & BMSW UNIT NON-INVERTER COMPATIBLE MODEL LIST

Existing Models			Service Models	
Models	Piping		Models	Piping
ATL35TV16W1	Gas pipe Ø9.5 Liquid pipe Ø6.4		JOBU35UV16W	Gas pipe Ø9.5 Liquid pipe Ø6.4
DTL35TV16W1				
FTL35TV16W1				
GTL35TV16W1				
CTL35TV16W1				
ETL35TV16W1				
MTL35TV16W1				
ATL35TV16W1A				
FTL28UV16W1				
FTL35UV16W1				
GTL28UV16W1				
GTL35UV16W1				
ATC50SRV162				
ATF50SRV162				
CTC50SRV162				
DTC50SRV162				
DTF50SRV162				
ETC50SRV162				
FTC50SRV162				
FTF50SRV162				
GTC50SRV162				
GTF50SRV162				
ATL50TV16U1				
ATL50TV16U2				
ATL50TV16U2A				
ATL50TV16U3				
CTL50TV16U1				
CTL50TV16U2				
DTL50TV16U1				
DTL50TV16U2				
DTL50TV16U2A				
DTL50TV16U3				
ETL50TV16U1				
ETL50TV16U2				
FTL50TV16U1				
FTL50TV16U2				
FTL50TV16U2A				
FTL50TV16U3				
GTL50TV16U1				
GTL50TV16U2				
GTL50TV16U2A				
GTL50TV16U3				
FTL50UV16U2				
FTL50UV16U3				
GTL50UV16U2				
GTL50UV16U3				
FTL50UV16V7				
GTL50UV16V7				
ATL50TV16V2				
CTL50TV16V2				
DTL50TV16V2				
FTL50TV16V2				
GTL50TV16V2				
ATL50TV16V2A				
ATL50TV16V3				
ATL50TV16V3A				
CTL50TV16V2A				
CTL50TV16V3				
DTL50TV16V2A				
DTL50TV16V3				
ETL50TV16V2A				
FTL50TV16V2A				
FTL50TV16V3				
GTL50TV16V2A				
GTL50TV16V3				
MTL50TV16V3				
FTL50UV16V2				
FTL50UV16V3				
GTL50UV16V2				
GTL50UV16V3				
ATC60SRV162	Gas pipe Ø12.7 Liquid pipe Ø6.4		JOBU60UV16U	Gas pipe Ø12.7 Liquid pipe Ø6.4
DTF60SRV162				
ATF60SRV162				
DTC60SRV162				
FTC60SRV162				
FTF60SRV162				
GTC60SRV162				
GTF60SRV162				
FTL60TV16U5				
FTQ60TV16U2				
GTO60TV16U2				
FTB60UV16U2				
FTQ60UV16U5				
GTE60UV16U2				
GTO60UV16U5				

Indoor Unit -Wiring Diagram



3D107586-1B

Applicable Model :- JOBU35UV16W, JOBU50UV16U, JOBU60UV16U