



3P556728-1E M18P037C

OPERATION MANUAL

VRV SYSTEM

Air Conditioners

MODELS

Wall-mounted type

FXAQ20ARVE6

FXAQ25ARVE6

FXAQ32ARVE6

FXAQ40ARVE6

FXAQ50ARVE6

FXAQ63ARVE6

FXARQ20ARVE6

FXARQ25ARVE6

FXARQ32ARVE6

FXARQ40ARVE6

FXARQ50ARVE6

FXARQ63ARVE6

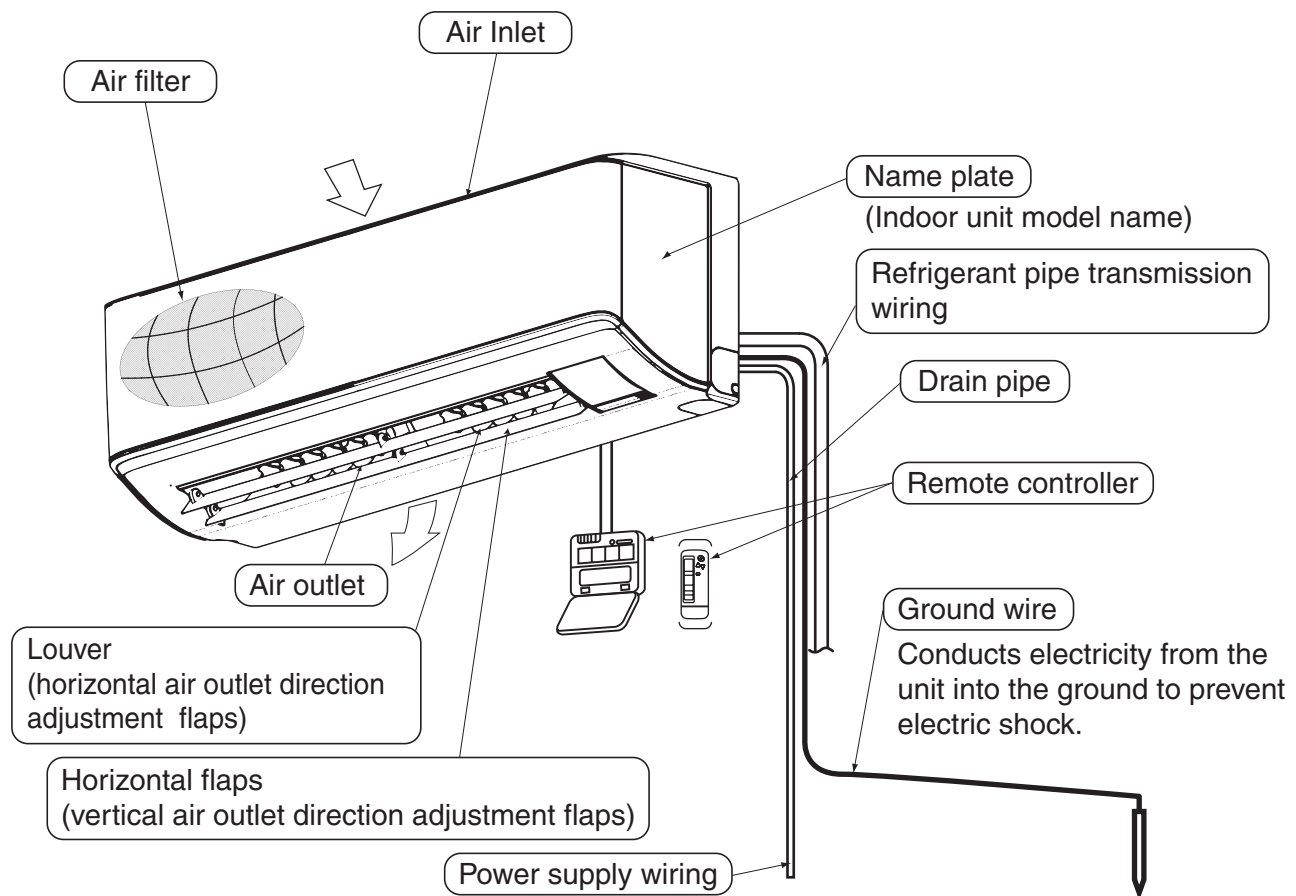

Thank you for purchasing this Daikin air conditioner. Carefully read this operation manual before using the air conditioner. It will tell you how to use the unit properly and help you if any trouble occurs. This manual explains about the indoor unit only. Use it along with the operation manual for the outdoor unit. After reading the manual, file it away for future reference.

The English text is the original instruction. Other languages are translations of the original instructions.

Important information regarding the refrigerant used

This product contains fluorinated greenhouse gases covered by the Kyoto Protocol.

Refrigerant type	R410A
GWP ⁽¹⁾ value	1975

⁽¹⁾ GWP = global warming potential

Periodical inspections for refrigerant leaks may be required depending on European or local legislation. Please contact your local dealer for more information.

SAFETY PRECAUTIONS

To gain full advantage of the air conditioner's functions and to avoid malfunction due to mishandling, please read this operation manual carefully before use.

This air conditioner is classified under "appliances not accessible to the general public".

- **The precautions described herein are classified as WARNING and CAUTION. They both contain important information regarding safety. Be sure to observe all precautions without fail.**

⚠ WARNING..... Failure to follow these instructions properly may result in personal injury or loss of life.

⚠ CAUTION..... Failure to observe these instructions properly may result in property damage or personal injury, which may be serious depending on the circumstances.

- **After reading, keep this manual in a convenient place so that you can refer to it whenever necessary. If the equipment is transferred to a new user, be sure also to hand over the manual.**

— **⚠ WARNING** —

- **Consult your local dealer about installation work.**
Doing the work yourself may result in water leakage, electric shocks or fire hazards.
 - **Consult your local dealer regarding modification, repair and maintenance of the air conditioner.**
Improper workmanship may result in water leakage, electric shocks or fire hazards.
 - **Beware of fire in case of refrigerant leakage.**
If the air conditioner is not operating correctly, i.e. not generating cool or warm air, refrigerant leakage could be the cause.
Consult your dealer for assistance.
The refrigerant used for the air conditioner is safe and normally does not leak. However, if the refrigerant leaks and gets in contact with a naked burner, heater or cooker, it may generate hazardous compounds. Turn off the air conditioner and call the dealer. Make sure to turn on the air conditioner after the qualified service person confirms that the leakage is repaired.
 - **Consult your local dealer regarding relocation and reinstallation of the air conditioner.**
Improper installation work may result in leakage, electric shocks or fire hazards.
-

— **⚠ CAUTION** —

- **Do not allow a child to mount on the outdoor unit or avoid placing any object on it.**
Falling or tumbling may result in injury.
 - **The appliance is not intended for use by unattended young children or persons who are incompetent to operate air conditioners.**
It may result in injury or electric shock.
 - **Children should be watched so that they do not play with the unit or its remote controller.**
Accidental operation by a child may result in injury or electric shock.
 - **Do not place objects in direct proximity of the outdoor unit and do not let leaves and other debris accumulate around the unit.**
Leaves are a hotbed for small animals which can enter the unit. Once in the unit, such animals can cause malfunctions, smoke or fire when making contact with electrical parts.
 - **Do not let children play on or around the outdoor unit.**
If they touch the unit carelessly, injury may be caused.
-

HOW TO ADJUST THE HORIZONTAL FAN DIRECTION ANGLE

Hold the tabs on edge louvers (horizontal air outlet direction adjustment flaps) down slightly and adjust left and right to match the room conditions or your preference.



Stop the horizontal flaps at a position where you can hold the tabs and adjust it left and right.

MAINTENANCE (FOR SERVICE PERSONNEL)

— **⚠ WARNING** —

- **Only a qualified person is allowed to perform maintenance without daily maintenance.**
 - **Before touching any of connection wirings, be sure to turn off all power supply switches.**
 - **Contact professional personnel about attachment of accessories and be sure to use only accessories specified by the manufacturer.**
If a defect results from your own workmanship, it may result in water leaks, electric shock or fire.
 - **Do not use flammable materials (e.g., hair-spray or insecticide) near the product.**
Do not clean the product with organic solvents such as paint thinner.
The use of organic solvents may cause crack damage to the product, electric shocks, or fire.
 - **Consult your dealer regarding cleaning the inside of the air conditioner.**
Improper cleaning may cause breakage of plastic parts, water leakage and other damage as well as electric shocks.
-

— **⚠ CAUTION** —

- **Before cleaning, be sure to stop unit operation, turn the power circuit breaker off or remove the power cord.**
Otherwise, an electric shock and injury may result.
 - **Do not wash the air conditioner with water, as this may result in electric shocks or fire.**
-

- **Watch your steps at the time of air filter cleaning or inspection.**

High-place work is required, to which utmost attention must be paid.

If the scaffold is unstable, you may fall or topple down, thus causing injury.

NOTE

- Do not remove the air filter except when cleaning. This may cause breakage.

HOW TO CLEAN THE AIR FILTER

Clean the air filter when the display shows “” (TIME TO CLEAN AIR FILTER).

- It will display that it will operate for a set amount of time.
- Increase the frequency of cleaning if the unit is installed in a room where the air is extremely contaminated.
- If the dirt becomes impossible to clean, change the air filter (Air filter for exchange is optional)

1. Open the front panel.

Place your fingers on the indentation on the left and right sides of the main unit and open until the panel stops.

(Follow the same procedure for closing.)

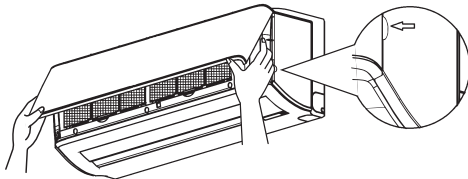

2. Pullout the air filter.

Push up the tab in the center of the air filter slightly then pull out in a downward direction.

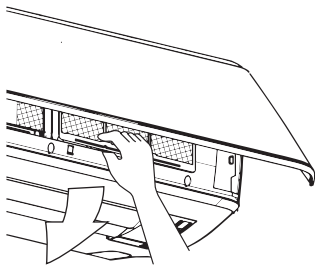

3. Clean the air filter.

Use vacuum cleaner **A)** or wash the air filter with water **B)**.

A) Using a vacuum cleaner



- B)** Washing with water
When the air filter is very dirty, use soft brush and neutral detergent



Remove water and dry in the shade.

NOTES

- Do not wash the air filter with hot water of more than 50°C, as doing so may result in discoloration and/or deformation.
- Do not expose it to fire, as doing so may result in burning.

4. Attach the air filter.

Once cleaning is done be sure to replace the air filter as it was.

5. Shut the front panel.

Refer to item No.1.

6. Press the FILTER SIGN RESET button on the remote controller.

The “TIME TO CLEAN AIR FILTER” display vanishes.

HOW TO CLEAN THE AIR OUTLET AND EXTERIOR

- Clean with soft cloth.
- When it is difficult to remove stains, use water or neutral detergent.

NOTES

- Do not use gasoline, benzene, thinner, polishing powder, liquid insecticide. It may cause discoloring or warping.
- Do not use water or air of 50°C or higher for cleaning air filters.
- When the flap is extremely contaminated, remove it as below and clean or exchange it. (Flap for exchange is optional.)

HOW TO CLEAN THE FRONT PANEL

You can remove the front panel to clean it.

NOTES

- Hold the front panel firmly so that it does not fall.
- Do not use gasoline, benzene, thinner, polishing powder, liquid insecticide. It may cause discoloring or warping.
- Do not let the indoor unit get wet. It may cause an electric shock or a fire.
- Do not scrub firmly when washing the blade with water.
The surface sealing may peel off.
- Do not use water or air of 50°C or higher for cleaning air filters and outside panels.
- Make sure the front panel is solidly in place.

1. Open the front panel.

Place your fingers on the indentation on the left and right sides of the main unit and open until the panel stops.

(Follow the same procedure for closing.)

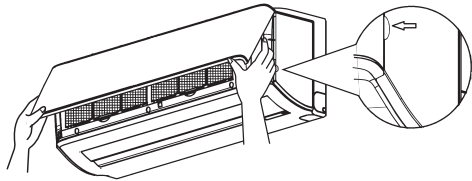

2. Remove the front panel.

Push the axes on either side of the front panel towards the center of the main unit and remove.

(You can also remove it by sliding the front panel either to the left or right and pulling it forward.)

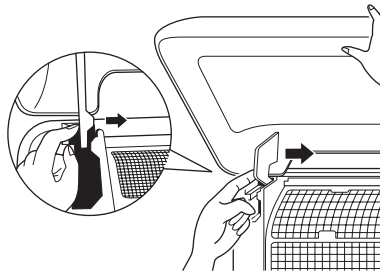

3. Clean the front panel.

- Wipe gently with a soft wet cloth.
- Only use neutral cleaning agents.
- After washing off, wipe off any excess water and dry in a shaded location.
- **When very grimy**

Directly apply the type of detergent used for cleaning ventilation fans or ovens, wait 10 minutes, and then rinse with water.

NOTE

- Do not wash the air conditioner with hot water of more than 50°C. Doing so may result in discoloration or deformation.

4. Attach the front panel.

Set the keys of the front panel into the slots and push them in all the way.

Close the front panel slowly in this state.

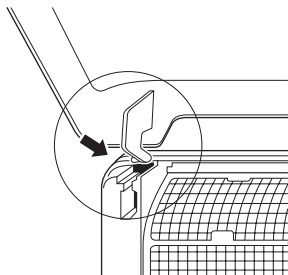

Disposal requirements



Your air conditioning product is marked with this symbol. This means that electrical and electronic products shall not be mixed with unsorted

household waste.

Do not try to dismantle the system yourself: the dismantling of the air conditioning system, treatment of the refrigerant, of oil and of other parts must be done by a qualified installer in accordance with relevant local and national legislation.

Air conditioners must be treated at a specialized treatment facility for re-use, recycling and recovery. By ensuring this product is disposed of correctly, you will help to prevent potential negative consequences for the environment and human health. Please contact the installer or local authority for more information.

Batteries must be removed from the remote controller and disposed of separately in accordance with relevant local and national legislation.

DAIKIN INDUSTRIES, LTD.

Head office:

Osaka Umeda Twin Towers South
1-13-1, Umeda, Kita-ku, Osaka, 530-0001, Japan

Tokyo office:

Yaesu Central Tower, Tokyo Midtown Yaesu,
2-2-1, Yaesu, Chuo-ku, Tokyo, 104-0028, Japan
<http://www.daikin.com>

INSTALLATION MANUAL

VRV* SYSTEM*Air Conditioners**

MODELS**Wall-mounted type**

**FXAQ20ARVE6
FXAQ25ARVE6
FXAQ32ARVE6
FXAQ40ARVE6
FXAQ50ARVE6
FXAQ63ARVE6**

**FXARQ20ARVE6
FXARQ25ARVE6
FXARQ32ARVE6
FXARQ40ARVE6
FXARQ50ARVE6
FXARQ63ARVE6**

**CAREFULLY READ THESE INSTRUCTIONS BEFORE INSTALLATION.
KEEP THIS MANUAL IN A HANDY PLACE FOR FUTURE REFERENCE.**



FXAQ20ARVE6	FXAQ40ARVE6	FXARQ20ARVE6	FXARQ40ARVE6	VRV SYSTEM
FXAQ25ARVE6	FXAQ50ARVE6	FXARQ25ARVE6	FXARQ50ARVE6	Air Conditioners
FXAQ32ARVE6	FXAQ63ARVE6	FXARQ32ARVE6	FXARQ63ARVE6	Installation manual

CONTENTS

1. SAFETY PRECAUTIONS.....	1
2. BEFORE INSTALLATION	3
3. SELECTING INSTALLATION SITE.....	5
4. INDOOR UNIT INSTALLATION	6
5. REFRIGERANT PIPING WORK	9
6. DRAIN PIPING WORK.....	12
7. ELECTRIC WIRING WORK	13
8. HOW TO CONNECT WIRINGS AND WIRING EXAMPLE	14
9. FIELD SETTINGS	20
10. TEST RUN.....	21

1. SAFETY PRECAUTIONS

Be sure to follow this “SAFETY PRECAUTIONS”.

This product comes under the term “appliances not accessible to the general public”.

This is a class A product. In a domestic environment this product may cause radio interference in which case the user may be required to take adequate measures.

This manual classifies the precautions into WARNINGS and CAUTIONS.

Be sure to follow all the precautions below: They are all important for ensuring safety.

 **WARNING**Indicates a potentially hazardous situation which, if not avoided, could result in death or serious injury.

 **CAUTION**Indicates a potentially hazardous situation which, if not avoided, may result in minor or moderate injury.
It may also be used to alert against unsafe practices.

- After the installation is completed, test the air conditioner and check if the air conditioner operates properly. Give the user adequate instructions concerning the use and cleaning of the indoor unit according to the Operation Manual. Ask the user to keep this manual and the Operation Manual together in a handy place for future reference.

WARNING

- Ask your local dealer or qualified personnel to carry out installation work. Improper installation may result in water leakage, electric shocks or a fire.
- Perform installation work in accordance with this installation manual. Improper installation may result in water leakage, electric shocks or a fire.
- Consult your local dealer regarding what to do in case of refrigerant leakage. When the air conditioner is installed in a small room, it is necessary to take proper measures so that the amount of any leaked refrigerant does not exceed the concentration limit in the event of a leakage. Otherwise, this may lead to an accident due to oxygen deficiency.
- Be sure to use only the specified parts and accessories for installation work. Failure to use the specified parts may result in the air conditioner falling down, water leakage, electric shocks, a fire, etc.

- Install the air conditioner on a foundation that can withstand its mass.
Insufficient strength may result in the air conditioner falling down and causing injury.
In addition, it may lead to vibration of indoor units and cause unpleasant chattering noise.
 - Carry out the specified installation work in consideration of strong winds, typhoons, or earthquakes.
Improper installation may result in an accident such as air conditioner falling.
 - Make certain that all electrical work is carried out by qualified personnel according to the applicable legislation (note 1) and this installation manual, using a separate circuit.
In addition, even if the wiring is short, make sure to use a wiring that has sufficient length and never connect additional wiring to make the length sufficient.
Insufficient capacity of the power supply circuit or improper electrical construction may lead to electric shocks or a fire.
(note 1) applicable legislation means “All international, national and local directives, laws, regulations and/or codes which are relevant and applicable for a certain product or domain”.
 - Earth the air conditioner.
Do not connect the earth wiring to gas or water piping, lightning conductor or telephone earth wiring.
Incomplete earthing may cause electric shocks or a fire.
A high surge current from lightning or other sources may cause damage to the air conditioner.
 - Be sure to install an earth leakage circuit breaker.
Failure to do so may cause electric shocks and a fire.
 - Disconnect the power supply before touching the electric components.
If you touch the live part, you may get an electric shocks.
 - Make sure that all wiring is secure, using the specified wiring and ensuring that external forces do not act on the terminal connections or wiring.
Incomplete connection or fixing may cause an overheat or a fire.
 - When wiring between the indoor and outdoor units, and wiring the power supply, form the wiring orderly so that the control box lid can be securely fastened.
If the control box lid is not in place, overheat of the terminals, electric shocks or a fire may be caused.
 - If refrigerant gas leaks during installation work, ventilate the area immediately.
Toxic gas may be produced if refrigerant gas comes into contact with a fire.
 - After completing the installation work, check to make sure that there is no leakage of refrigerant gas.
Toxic gas may be produced if refrigerant gas leaks into the room and comes into contact with a source of a fire, such as a fan heater, stove or cooker.
 - Never directly touch any accidental leaking refrigerant. This could result in severe wounds caused by frost-bite.
-

 **CAUTION**

- Install drain piping according to this installation manual to ensure good drainage, and insulate the piping to prevent condensation.
Improper drain piping may cause water leakage, make the furniture get wet.
 - Install the air conditioner, power supply wiring, remote controller wiring and transmission wiring at least 1 meter away from televisions or radios to prevent image interference or noise.
(Depending on the radio waves, a distance of 1 meter may not be sufficient to eliminate the noise.)
 - Install the indoor unit as far as possible from fluorescent lamps.
If a wireless remote controller kit is installed, the transmission distance may be shorter in a room where an electronic lighting type (inverter or rapid start type) fluorescent lamp is installed.
 - Do not install the air conditioner in places such as the following:
 1. Where there is mist of oil, oil spray or vapour for example a kitchen.
Resin parts may deteriorate, and cause them to fall out or water to leak.
 2. Where corrosive gas, such as sulfurous acid gas, is produced.
Corrosion of copper pipings or brazed parts may cause the refrigerant to leak.
 3. Where there is machinery which emits electromagnetic waves.
Electromagnetic waves may disturb the control system, and cause malfunction of the equipment.
 4. Where flammable gases may leak, where carbon fibre or ignitable dust is suspended in the air or where volatile flammables, such as thinner or gasoline, are handled.
If the gas should leak and remained around the air conditioner, it may cause ignition.
 - The air conditioner is not intended for use in a potentially explosive atmosphere.
-

2. BEFORE INSTALLATION

Do not exert pressure on the resin parts when opening the unit or when moving it after opening. Be sure to check the type of R410A refrigerant to be used before doing any work. (Using an incorrect refrigerant will prevent normal operation of the unit.)





- When opening the unit or moving it after opening, be sure to lift it by holding on to the lifting lugs without exerting any pressure on other parts, especially, drain piping, and other resin parts.
- Decide upon a line of transport.
- Leave the unit inside its packaging while moving, until reaching the installation site. Use a sling of soft material, where unpacking is unavoidable or protective plates together with a rope when lifting, to avoid damage or scratches to the unit.
- Refer to the installation manual of the outdoor unit for items not described in this manual.
- Do not dispose of any parts necessary for installation until the installation is complete.

2-1 PRECAUTIONS

- Be sure to read this manual before installing the indoor unit.
- When selecting installation site, refer to the installation pattern.
- An inverter air conditioner may cause home appliances product noise. When selecting the location for installation, keep the air conditioner and wiring a proper distance away (at least 1 Meter) from radios, computers and stereo equipments.
- Entrust installation to the place of purchase or a qualified serviceman. Improper installation could lead to leaks and, in worse cases, electric shock or fire.
- Use only parts provided with the unit or parts satisfying required specifications. Unspecified parts could cause the unit to fall out of place, or could lead to leaks and, in worse cases, electric shock or fire.
- Do not install or operate the unit in rooms mentioned below.
 - **Laden with mineral oil, or filled with oil vapor or spray like in kitchens. (Plastic parts may deteriorate which could eventually cause the unit to fall out of place, or could lead to leaks.)**
 - **Where corrosive gas like sulfurous gas exists. (Copper tubing and brazed spots may corrode, which could eventually lead to refrigerant leaks.)**
 - **Where volatile flammable gas like thinner or gasoline is used.**
 - **Where exposed to combustible gases and where volatile flammable gas like thinner or gasoline is used. (Gas in the vicinity of the unit could ignite.)**
 - **Where machines can generate electromagnetic waves. (Control system may malfunction.)**
 - **Where the air contains high levels of salt such as that near the ocean and where voltage fluctuates greatly such as that in factories. Also in vehicles or vessels.**

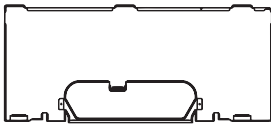
2-2 ACCESSORIES

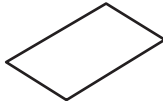
Check the following accessories are included with your unit.

Name	(1) Installation panel	(2) Attachment screws for the installation panel	(3) Paper pattern for installation
Quantity	1 set	7 pcs.	1 pc
Shape		 M4 × 25L	
Name	(4) Clamp	(5) Securing screws	(Other) • Operation manual • Installation manual • E-Waste (Guidelines)
Quantity	1 large 2 small	2 pcs.	
Shape		 M4 × 12L	

2-3 OPTIONAL ACCESSORIES

- These are two types of remote controllers: wired and wireless. Select a remote controller according to customer request and install in an appropriate place.

Remote controller type		Model
Wired type		BRC1C62, BRC1E63, BRC1D61
Wireless type	Heat pump type	BRC4M150W16
	Cooling only type	

* Refer to an installation manual attached to the remote controller.

NOTE

- If the customer wishes to use a remote controller that is not listed above, select a suitable remote controller after consulting catalogs and technical materials.

FOR THE FOLLOWING ITEMS, TAKE SPECIAL CARE DURING CONSTRUCTION AND CHECK AFTER INSTALLATION IS FINISHED.

a. Items to be checked after completion of work



Items to be checked	If not properly done, what is likely to occur	Check
Are the indoor and outdoor unit fixed firmly?	The units may drop, vibrate or make noise.	
Is the outdoor unit fully installed?	The unit may malfunction or the components burn out.	
Is the gas leak test finished?	It may result in insufficient cooling.	
Is the unit fully insulated?	Condensate water may drip.	
Does drainage flow smoothly?	Condensate water may drip.	
Does the power supply voltage correspond to that shown on the name plate?	The unit may malfunction or the components burn out.	
Are wiring and piping correct?	The unit may malfunction or the components burn out.	
Is the unit safely earthed?	Dangerous at electric leakage.	
Is wiring size according to specifications?	The unit may malfunction or the components burn out.	
Is something blocking the air outlet or inlet of either the indoor or outdoor units?	It may result in insufficient cooling.	
Are refrigerant piping length and additional refrigerant charge noted down?	The refrigerant charge in the system is not clear.	

b. Items to be checked at time of delivery

Also review the "SAFETY PRECAUTIONS"

Items to be checked	Check
Are the control box cover, air filter, suction grille attached?	
Did you explain about operations while showing the instruction manual to your customer?	
Did you hand the instruction manual over to your customer?	

c. Points for explanation about operations

The items with  WARNING and  CAUTION marks in the instruction manual are the items pertaining to possibilities for bodily injury and material damage in addition to the general usage of the product. Accordingly, it is necessary that you make a full explanation about the described contents and also ask your customers to read the instruction manual.

2-4 NOTE TO THE INSTALLER

Be sure to instruct customers how to properly operate the unit (especially cleaning filters, operating different functions, and adjusting the temperature) by having them carry out operations themselves while looking at the manual.

3. SELECTING INSTALLATION SITE

(1) Select an installation site where the following conditions are fulfilled and that meets with your customer's approval.

- In the upper space (including the back of the ceiling) of the indoor unit where there is no possible dripping of water from the refrigerant pipe, drain pipe, water pipe, etc.
- Where the wall is strong enough to bear the indoor unit weight.
- Where sufficient clearance for installation and maintenance can be ensured.

(Refer to Fig. 1 and Fig. 2)

- Where optimum air distribution can be ensured.
- Where nothing blocks the air passage.
- Where condensate can be properly drained.
- Where the wall is not significantly tilted.
- Where not exposed to combustible gases.
- Where pipe between indoor and outdoor units is possible within the allowable limit.
(Refer to the installation manual of the outdoor unit.)
- Install the indoor and outdoor units, power cable and transmission wiring, at least 1 m from TVs and radios, to prevent distorted pictures and static. (Depending on the type and source of the electrical waves, static may be heard even when more than 1 m away.)
- Install the indoor unit no less than 2.5 m above the floor. Where unavoidably lower, take what measures are necessary to keep hands out of the air inlet.
- Where the cool (warm) air reaches all across the room.

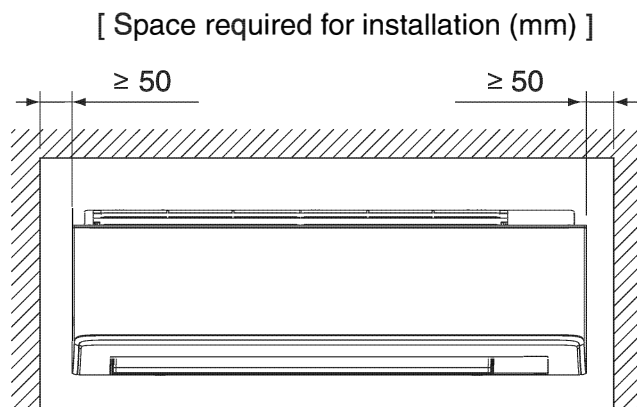

Fig. 1

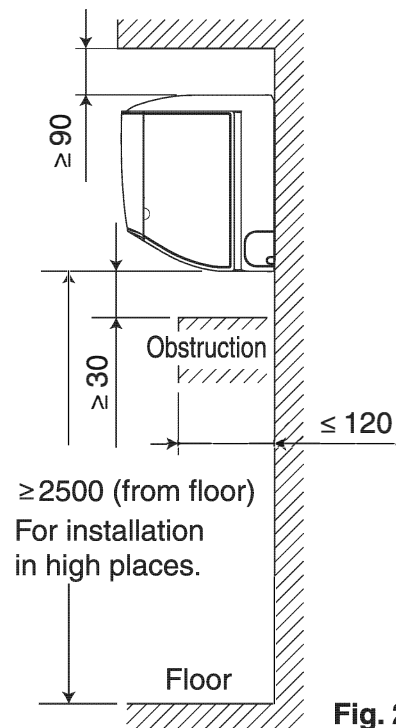

Fig. 2

⚠ CAUTION

- The indoor and outdoor units and the power supply wiring and remote controller cord must be installed at least 1m away from any televisions or radios. This is to prevent interference with picture and sound reception. (Interference may occur even at 1m away depending on the reception quality.)
- If installing the wireless kit, the distance of the signal sent from the remote controller might be shorter if there are fluorescent lights which are electrically started (such as with inverters, rapid starters, etc.) in the room. The indoor unit should be installed as far away from fluorescent lights as possible.

- (2) Consider whether the place where the unit will be installed can support the full weight of the unit, and reinforce it with boards and beams, etc. if needed before proceeding with the installation. Also, reinforce the place to prevent vibration and noise before installing. (The installation pitch can be found on the paper pattern for installation (3), so refer to it when considering the necessity for reinforcing the location.)
- (3) The indoor unit may not be directly installed on the wall. Use the attached installation panel (1) before installing the unit.

4. INDOOR UNIT INSTALLATION

- Use only accessories and parts which are of the designated specification when installing.

⚠ CAUTION

- Install so that the unit does not tilt to either side or forward.
- Do not hold the unit by the horizontal flaps when lifting it. (This may damage the horizontal flaps.)

(1) Open the piping through-hole.

- The refrigerant pipe and drain pipe can be passed out in one of 6 directions: left, bottom-left, back-left, right, bottom-right, and back-right. (Refer to Fig. 3)
 - Using the paper pattern for installation (3), choose where to pass the piping out and open a through-hole ($\phi 80$) in the wall.
- Open the hole so that there is a downward slope for the drain piping. (See “ 6.DRAIN PIPING WORK ”)

(2) Remove the installation panel (1) from the unit and attach to the wall.

(The installation panel is temporarily attached to the unit with screw.

(Refer to Fig. 3)

- Check the location for the hole using the included paper pattern for installation (3).
 - Choose a location so that there is at least a 90 mm gap between the ceiling and the main unit.
- Temporarily attach the installation panel (1) at the temporary-securing position on the paper pattern for installation (3) and use a level to make sure the drain hose is either level or tilted slightly downward.
- Secure the installation panel (1) to the wall using either screws or bolts.
 - If using the attachment screws for the installation panel (2), attach using at least 4 screws on either side of the recommended installation cleat position on the included paper pattern for installation (3).
 - If using bolts, attach using a M8 - M10 bolt (for a total of 2 bolts) on either side.
 - If dealing with concrete, use commercially available foundation bolts (M8 - M10).

(3) If using the left, bottom-left, right, or bottom-right positions for the piping, cut out the through-hole for the piping in the front grille. (Refer to Fig. 4)

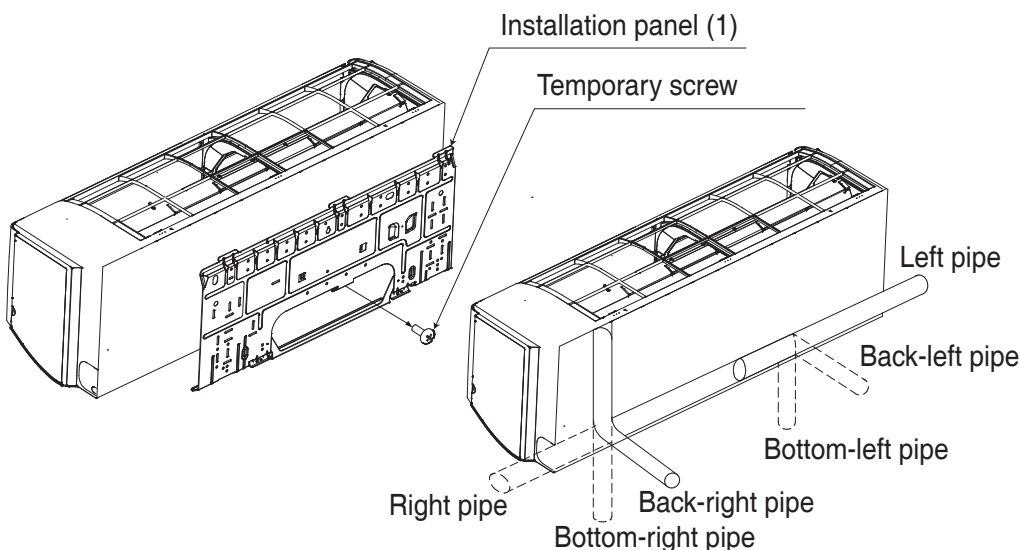

Fig. 3

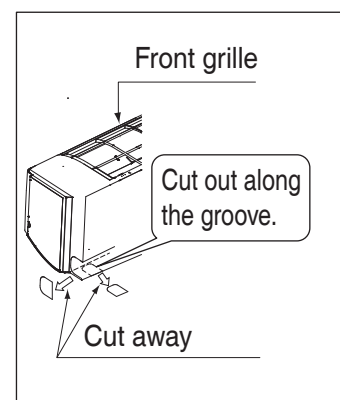

Fig. 4

(4) Remove the front panel and the service cover. (Refer to Fig. 5)

< How to remove the front panel and service cover >

- (1) Open the front panel to the point where it stops.
- (2) Push the axes on either side of the front panel towards the center of the main unit and remove. (You can also remove it by sliding the front panel either to the left or right and pulling it forward.)
- (3) Remove the screw from the service cover and pull the handle forward.

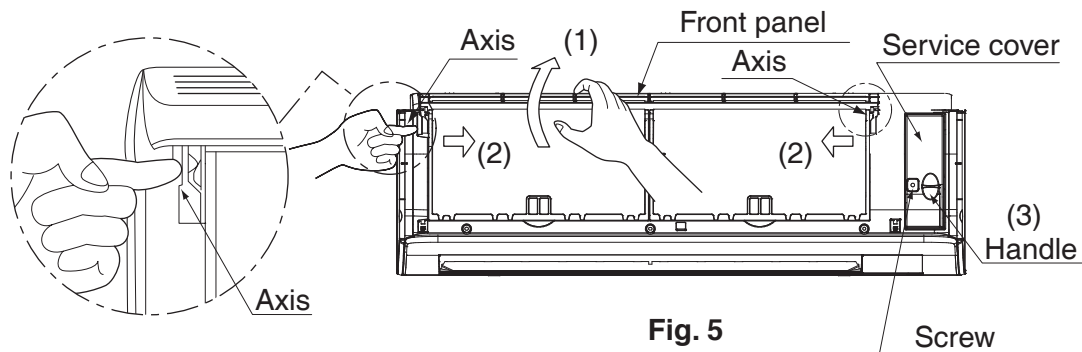

Fig. 5

(5) Point the pipe in the direction it will be passed out.

For right, bottom-right, and back-right piping (Refer to Fig. 6)

- Wrap the drain hose and the refrigerant piping together with the finishing tape so that the drain hose is below the refrigerant piping.

For left, bottom-left, and left-back piping

- Remove the front grille. (Refer to Fig. 7)

< How to remove the front grille >

Remove the front grille as described below when securing the indoor unit with screws or when attaching Optional Accessories (wireless remote controller, adapter PC board, etc.).

- (1) Remove the front panel.
- (2) Remove the screws (3 places) securing the front grille.
- (3) Remove the tabs (3 places) securing the front grille by pushing them in the direction of the arrows.
- (4) Making sure not to catch the horizontal flaps, remove the front grille by pulling in the direction of the arrow.

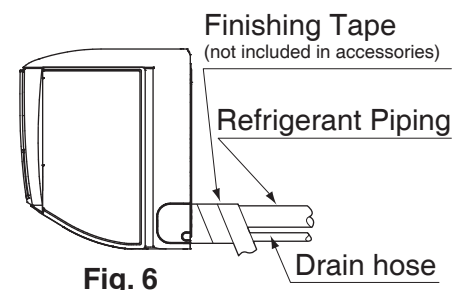

Fig. 6

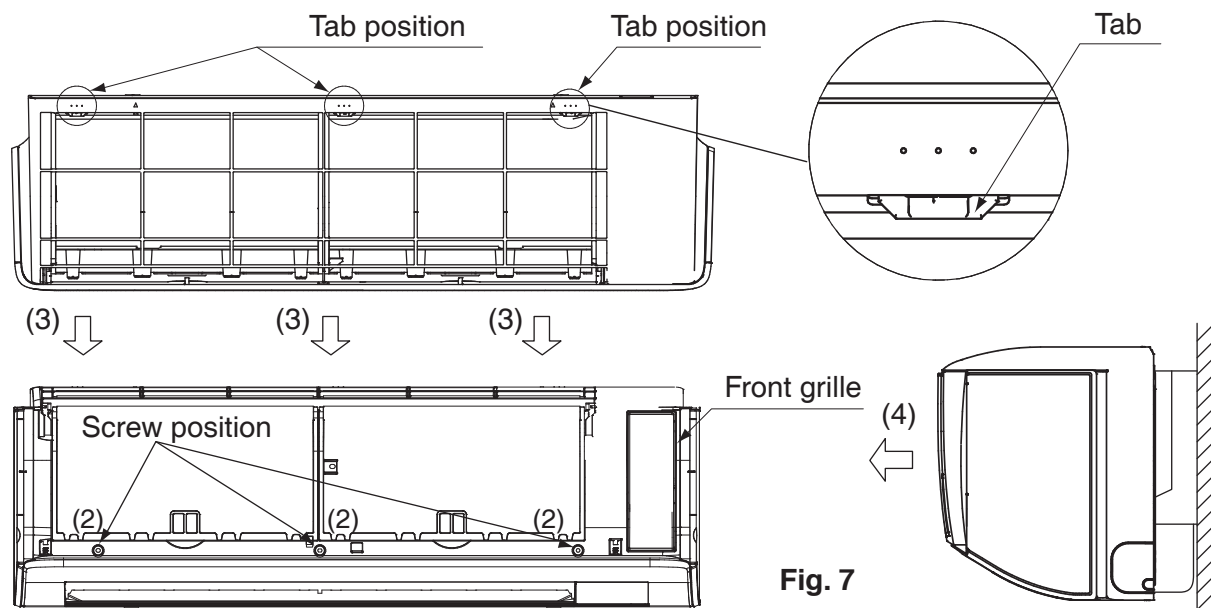
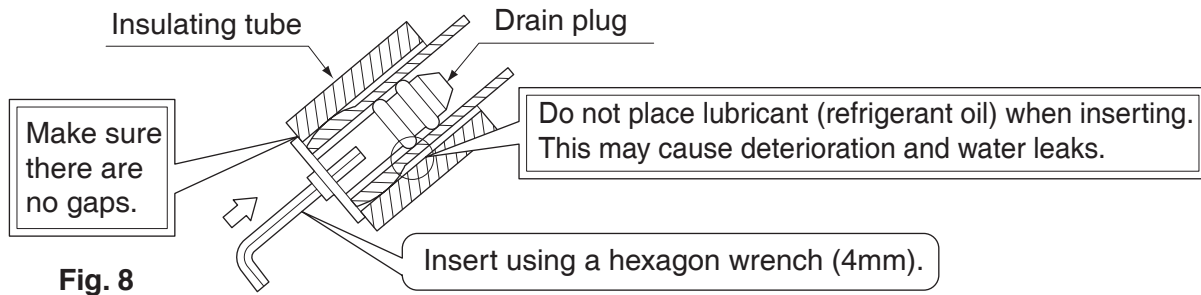

Fig. 7

- Remove the drain plug, the insulation tubing, and the drain hose from the drain pan and replace. (Refer to Fig. 8)
- Connect the local refrigerant piping ahead of time, matching it to the liquid pipe and gas pipe marks engraved on the installation panel (1).

< Replacing the drain hose and drain plug >

- (1) Remove the drain plug and insulation tubing.
- (2) Remove the drain hose and replace onto the left side.
- (3) Replace the drain plug and the insulation tubing onto the right side.



(6) Hook the indoor unit onto the installation panel. (Refer to Fig. 9)

- Placing buffering material between the wall and the indoor unit at this time will make work easier.

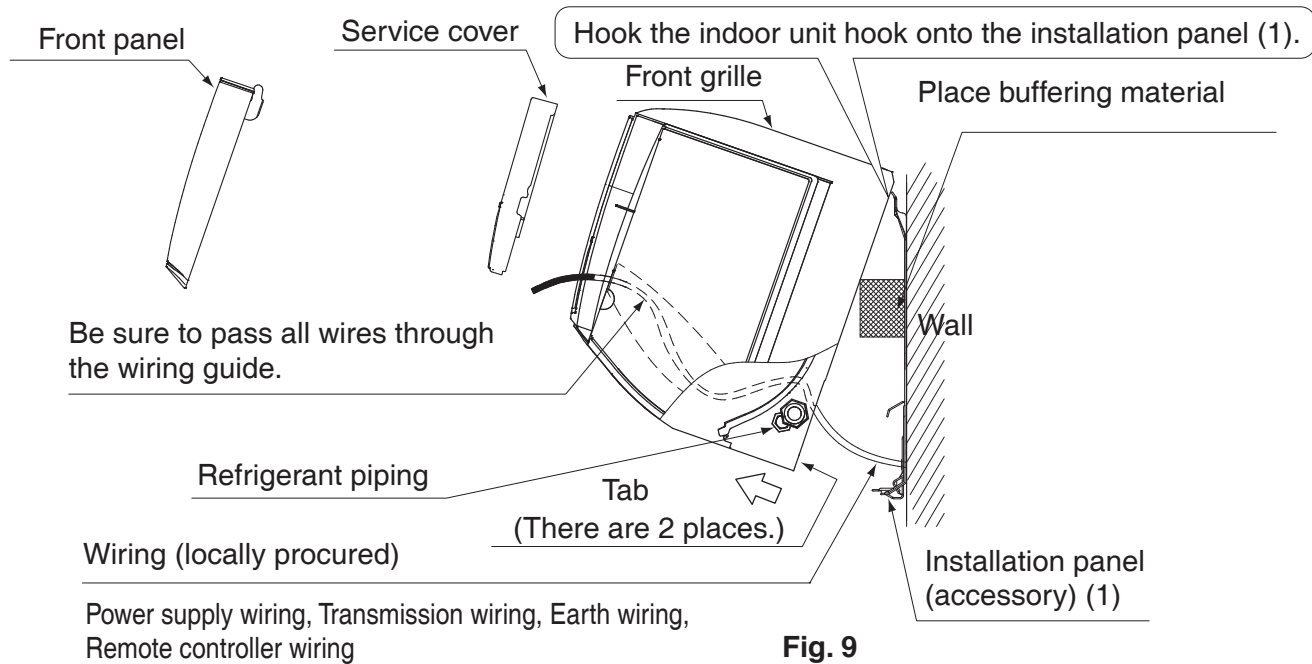

For right, bottom-right, and back-right piping

- Pass the drain hose and the refrigerant piping to the wall.

(7) Pass power supply wiring, transmission wiring, earth wiring, and remote controller wiring through the wiring guide in through the back of the indoor unit and to the front.

(8) Connect the piping. (See “5.REFRIGERANT PIPING WORK” and Fig. 10)

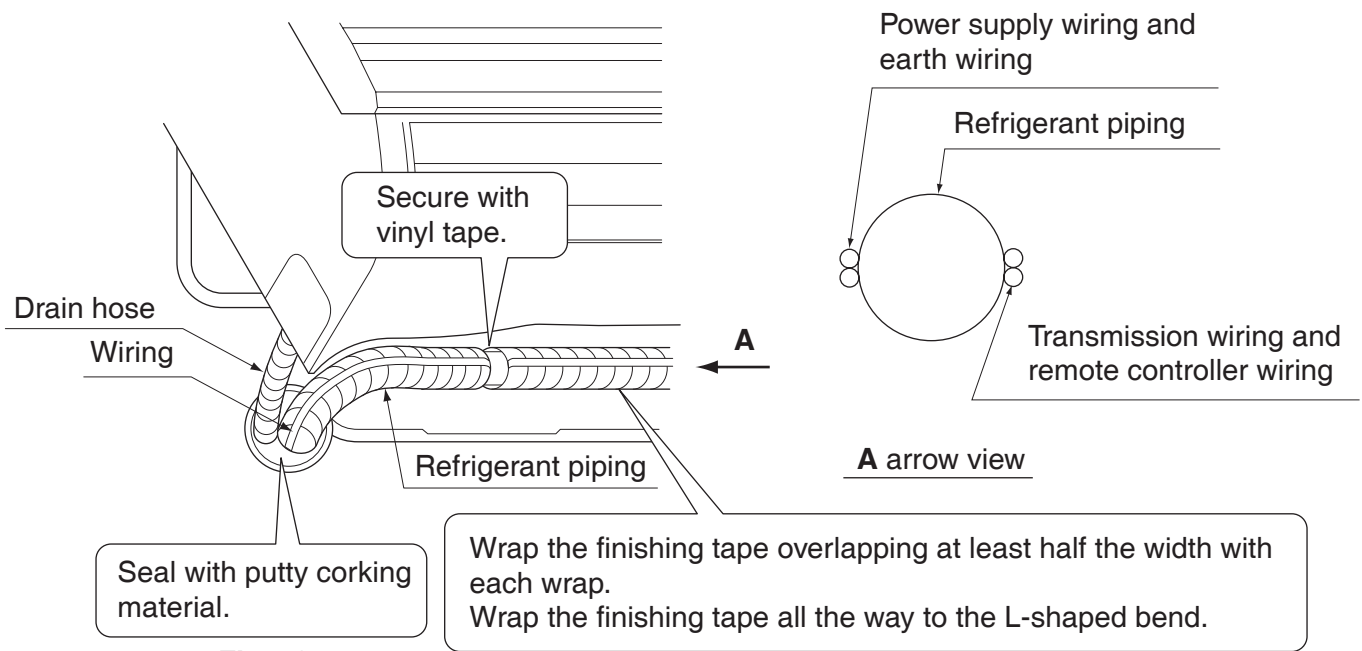

Fig. 10

- To avoid the influence of noise from the power supply line on the transmission wiring and the remote controller wiring, these wirings must be kept as far as possible from the power/earth wirings. As shown in the figure, keep the power supply wiring and the earth wiring together. Keep the transmission and remote controller wirings together and route them maintaining a good distance from the power supply/earth wirings (that is, on the other side of the power supply/earth wirings). Then, fix them securely on the refrigerant pipe.
- Seal the piping through-hole with putty corking material.

(9) Push on both bottom edges of the indoor unit using both hands and hook the tab on the back of the indoor unit onto the installation panel (1). (Refer to Fig. 9)

- At this time remove the buffering material placed in step (6).
- Make sure power supply wiring, transmission wiring, earth wiring and remote controller wiring are not caught inside the indoor unit.

■ When screwing in the indoor unit

- Remove the front grille. (Refer to Fig. 7)
- Secure the indoor unit to the installation panel (1) with the securing screws (5). (Refer to Fig. 11)

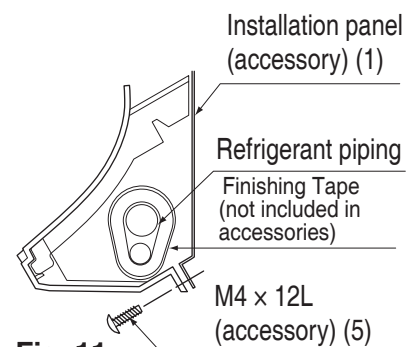

Fig. 11

5. REFRIGERANT PIPING WORK

- For the outdoor unit refrigerant piping, refer to the installation manual attached to the outdoor unit.
- Carry out insulation of both gas and liquid refrigerant piping securely. If not insulated, it may cause water leakage. For gas piping, use insulation material of which heat resistant temperature is not less than 120°C. For use under high humidity, strengthen the insulation material for refrigerant piping. If not strengthened, the surface of insulation material may sweat.
- Before installation work, make sure that the refrigerant is R410A. (Unless the refrigerant is R410A, the normal operation cannot be expected.)

CAUTION

This air conditioner is a dedicated model for refrigerant R410A. Make sure to meet the requirements shown below and carry out installation work.

- Use dedicated piping cutters and flaring tools for R410A.
- When making a flare connection, coat the flared inner surface only with ether oil or ester oil.
- Use only the flare nuts attached to the air conditioner. If other flare nuts are used, it may cause refrigerant leakage.
- To prevent contamination or moisture from getting into the piping, take measures such as pinching or taping the pipings.

Do not mix substance other than the specified refrigerant such as air into the refrigeration circuit. If the refrigerant leaks during the work, ventilate the room.

- The refrigerant is pre-charged in the outdoor unit.
- When connecting the pipings to the air conditioner, make sure to use a spanner and a torque wrench as shown in Fig. 12.
- For the dimension of flared part and the tightening torque, refer to the Table 1.
- When making a flare connection, coat the flared inner surface only with ether oil or ester oil.

(Refer to Fig. 13)

Then, turn the flare nut 3 to 4 times with your hand and screw in the nut.

CAUTION

- Over-tightening may cause the flare nuts to crack or the refrigerant to leak.

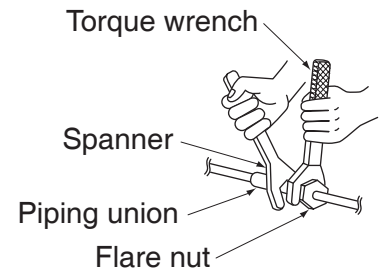

Fig. 12

Coat the flared inner surface only with ether oil or ester oil.

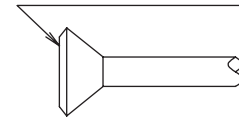

Fig. 13

NOTE

- Use the flare nut included with the unit main body.

Table 1

Pipe size	Tightening torque (N·m)	Dimension for processing flare A (mm)	Flare shape
φ 6.4 (1/4")	15.7 ± 1.5	8.9 ± 0.2	
φ 9.5 (3/8")	36.3 ± 3.6	13.0 ± 0.2	
φ 12.7 (1/2")	54.9 ± 5.4	16.4 ± 0.2	
φ 15.9 (5/8")	68.6 ± 6.8	19.5 ± 0.2	

- Refer to Table 1 to determine the proper tightening torque.

— **Not recommendable but in case of emergency** —

You must use a torque wrench but if you are obliged to install the unit without a torque wrench, you may follow the installation method mentioned below.

After the work is finished, make sure to check that there is no gas leak.

When you keep on tightening the flare nut with a spanner, there is a point where the tightening torque suddenly increases. From that position, further tighten the flare nut the angle shown below:

Table 2

Pipe size	Further tightening angle	Recommended arm length of tool
φ 6.4 (1/4")	60 - 90 degrees	Approx. 150mm
φ 9.5 (3/8")	60 - 90 degrees	Approx. 200mm
φ12.7 (1/2")	30 - 60 degrees	Approx. 250mm
φ15.9 (5/8")	30 - 60 degrees	Approx. 300mm

After the work is finished, make sure to check that there is no gas leak.

— **CAUTION** —

CAUTION TO BE TAKEN WHEN BRAZING REFRIGERANT PIPING

“Do not use flux when brazing refrigerant piping. Therefore, use the phosphor copper brazing filler metal (BCuP-2: JIS Z 3264/B-Cu93P-710/795: ISO 3677) which does not require flux.”

(Flux has extremely harmful influence on refrigerant piping systems. For instance, if the chlorine based flux is used, it will cause pipe corrosion or, in particular, if the flux contains fluorine, it will damage the refrigerant oil.)

- Before brazing local refrigerant piping, nitrogen gas shall be blown through the piping to expel air from the piping.
If your brazing is done without nitrogen gas blowing, a large amount of oxide film develops inside the piping, and could cause system malfunction.
- When brazing the refrigerant piping, only begin brazing after having carried out nitrogen substitution or while inserting nitrogen into the refrigerant piping. Once this is done, connect the indoor unit with a flared or a flanged connection.
- Nitrogen should be set to 0.02 MPa with a pressure-reducing valve if brazing while inserting nitrogen into the piping. (Refer to Fig.14)

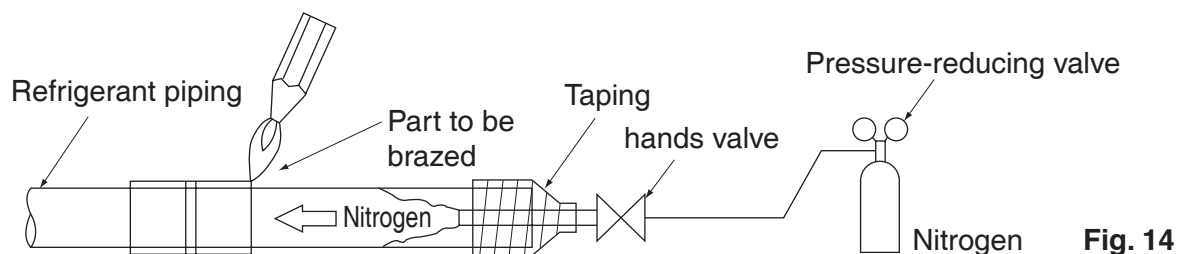
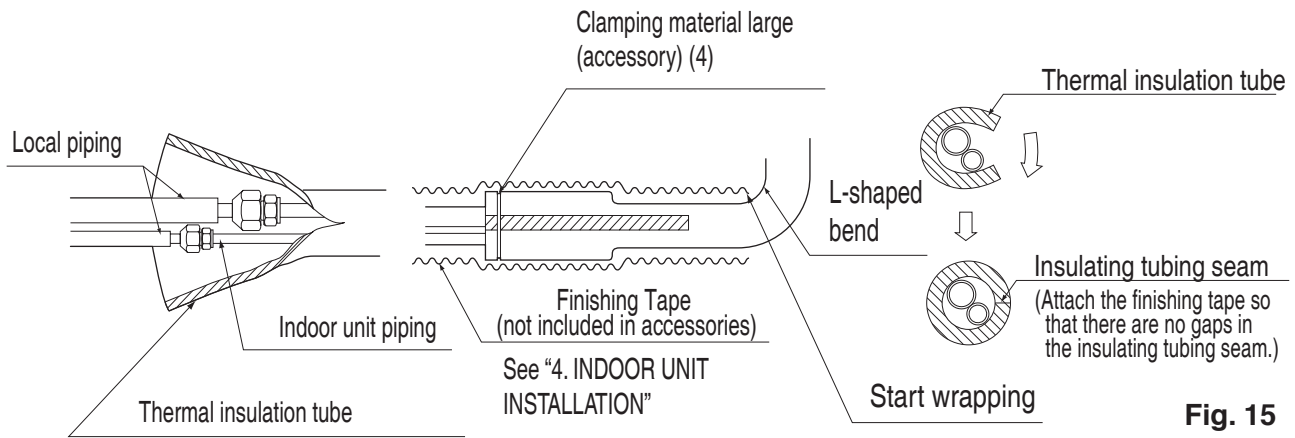

Fig. 14

— **CAUTION** —

Be sure to insulate any field piping all the way to the piping connection inside the unit. Any exposed piping may cause condensation or burns if touched.

- After checking for gas leaks, be sure to insulate the pipe connections using the thermal insulation tube & finishing tape. The finishing tape should be wrapped from the L-shaped bend all the way to the inside the unit (**Refer to fig.15**)



CAUTION

Be sure to insulate any field piping all the way to the piping connection inside the unit. Any exposed piping may cause condensation or burns if touched.

6. DRAIN PIPING WORK

(1) Install the drain piping. (Refer to Fig. 16)

- The drain pipe should be short with a downward slope and should prevent air pockets from forming.
- Watch out for the points in the **Fig. 16** when performing drain work.

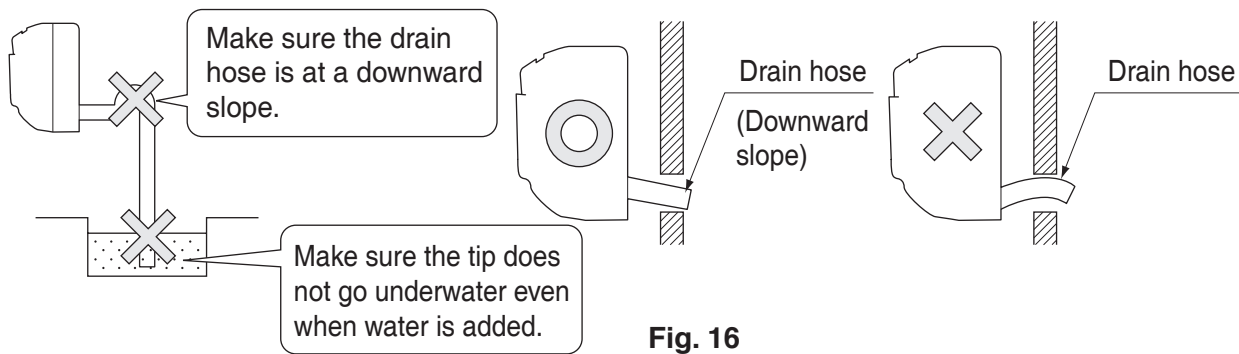

- When extending the drain hose, use a commercially available drain extension hose, and be sure to insulate the extended section of the drain hose which is indoors. (**Refer to Fig. 17**)

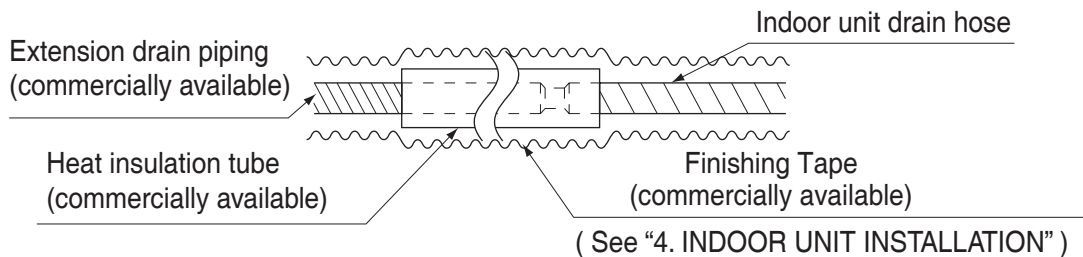

- Make sure the diameter of the piping is the same as the piping (hard vinyl chloride, nominal diameter 13mm) or bigger.

- When directly connecting a hard vinyl chloride pipe joint (nominal diameter 13mm) to the drain hose connected to the indoor unit (i.e. for embedded piping, etc.), use a commercially available hard vinyl chloride pipe joint (nominal diameter 13mm). (Refer to Fig. 18)

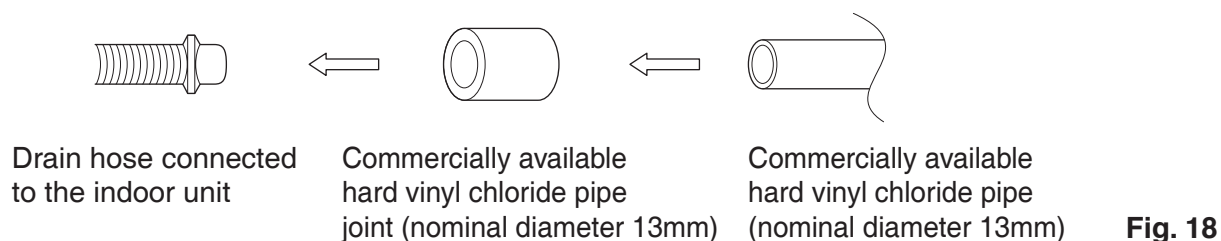

(2) Make sure the drain works properly.

- After drain work is complete, perform a drain check by opening the front panel, **removing the air filter**, pouring water into the drain pan, and making sure water flows smoothly out of the drain hose. (Refer to Fig. 19)

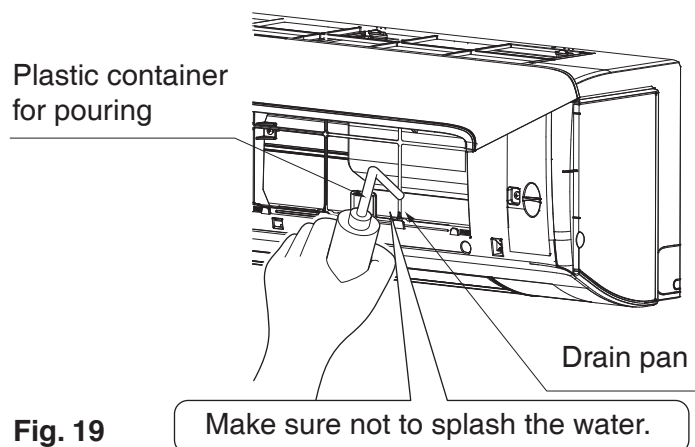

⚠ CAUTION

- Drain piping connections
Do not connect the drain piping directly to sewage pipes that smell of ammonia. The ammonia in the sewage might enter the indoor unit through the drain pipes and corrode the heat exchanger.
- Keep in mind that it will become the cause of getting drain pipe blocked if water collects on drain pipe.

7. ELECTRIC WIRING WORK

7-1 GENERAL INSTRUCTIONS

- All field supplied parts and materials and electric works must conform to local codes.
- Use copper wire only.
- For electric wiring work, refer to also "WIRING DIAGRAM" attached to the unit body.
- For remote controller wiring details, refer to the installation manual attached to the remote controller.
- All wiring must be performed by an authorized electrician.
- This system consists of multiple indoor units. Mark each indoor unit as unit A, unit B..., and be sure the terminal board wiring to the outdoor unit and BS unit are properly matched. If wiring and piping between the outdoor unit and an indoor unit are mismatched, the system may cause a malfunction.
- A circuit breaker capable of shutting down power supply to the entire system must be installed.
- Refer to the installation manual attached to the outdoor unit for the size of power supply wiring connected to the outdoor unit, the capacity of the circuit breaker and switch, and wiring instructions.
- Be sure to earth the air conditioner.
- Do not connect the earth wire to gas pipes, water pipes, lightning rods, or telephone earth wires.
 - Gas pipes: might cause explosions or fire if gas leaks.
 - Water pipes: no earthing effect if hard vinyl piping is used.
 - Telephone earth wires or lightning rods: might cause abnormally high electric potential in the earth during lightning storms.

7-2 ELECTRICAL CHARACTERISTICS

Model	Units			Power supply		Fan motor	
	Hz	Volts	Voltage range	MCA	MFA	kW	FLA
FXAQ20ARVE6/FXARQ20ARVE6	50	220-240	Max. 264 Min. 198	0.3	15	0.048	0.2
FXAQ25ARVE6/FXARQ25ARVE6				0.4	15	0.048	0.3
FXAQ32ARVE6/FXARQ32ARVE6				0.4	15	0.048	0.3
FXAQ40ARVE6/FXARQ40ARVE6				0.4	15	0.048	0.3
FXAQ50ARVE6/FXARQ50ARVE6				0.5	15	0.048	0.4
FXAQ63ARVE6/FXARQ63ARVE6				0.7	15	0.048	0.6
FXAQ20ARVE6/FXARQ20ARVE6	60	220	Max. 242 Min. 198	0.3	15	0.048	0.2
FXAQ25ARVE6/FXARQ25ARVE6				0.4	15	0.048	0.3
FXAQ32ARVE6/FXARQ32ARVE6				0.4	15	0.048	0.3
FXAQ40ARVE6/FXARQ40ARVE6				0.4	15	0.048	0.3
FXAQ50ARVE6/FXARQ50ARVE6				0.5	15	0.048	0.4
FXAQ63ARVE6/FXARQ63ARVE6				0.7	15	0.048	0.6

MCA: Min. Circuit Amps (A);

MFA: Max. Fuse Amps (A)

kW: Fan Motor Rated Output (kW);

FLA: Full Load Amps (A)

7-3 SPECIFICATIONS FOR FIELD SUPPLIED FUSES AND WIRE

Model	Power supply wiring			Remote controller wiring Transmission wiring	
	Field fuses 	Wire	Size	Wire	Size
FXAQ20ARVE6/FXARQ20ARVE6	15A	H05VV - U3G NOTE 1)	Wire size and length must comply with local codes.	Vinyl cord with sheath or cable (2 wire) NOTE 2)	0.75 - 1.25 mm ²
FXAQ25ARVE6/FXARQ25ARVE6					
FXAQ32ARVE6/FXARQ32ARVE6					
FXAQ40ARVE6/FXARQ40ARVE6					
FXAQ50ARVE6/FXARQ50ARVE6					
FXAQ63ARVE6/FXARQ63ARVE6					

Allowable length of transmission wirings and remote controller wiring are as follows.

(1) Outdoor unit - Indoor unit: Max. 1000m (Max. wiring length: 2000m)

(2) Indoor unit - Remote controller: Max. 500m

NOTE

- Shows only in case of protected pipes. Use H07RN-F in case of no protection.
- Vinyl cord with sheath or cable (Insulated thickness : 1mm or more)

CAUTION

- Arrange the wires and fix a cover firmly so that the cover does not float during wiring work.
- Do not clamp remote controller wiring and transmission wiring together with power supply wiring. Doing so may cause malfunction.
- Remote controller wiring and transmission wiring should be located at least 50 mm from power supply wiring. Not following this guideline may result in malfunction due to electrical noise.

8. HOW TO CONNECT WIRINGS AND WIRING EXAMPLE

8-1 HOW TO CONNECT WIRINGS

Methods of wiring power supply, units and connecting remote controller wiring

- Power supply wiring and earth wire

Unscrew and remove the service cover.

Connect the power supply wiring and earth wiring to the power supply terminal block (3P).

When doing this, tie the power supply wiring and the earth wiring using the included clamp (small) (4) and then firmly secure using the included clamp (small) (4) according to the figure.

(Refer to Fig. 23)

- Transmission wiring and remote controller wiring
Unscrew and remove the service cover.
Connect the remote controller wiring and the transmission wiring to the terminal block (6P).
When doing this, tie the remote controller wiring and the transmission wiring using the included clamp (small) (4) and then firmly secure using the included clamp (small) (4) according to the figure. **(Refer to Fig. 23)**
- Be sure to attach it to prevent the infiltration of water as well as any insects and other small creatures from the outside. Otherwise a short-circuit may occur inside the control box.

⚠ CAUTION FOR WIRING

- For connection to the terminal block, use ring type crimp style terminals with insulation sleeve or insulate the wirings properly.

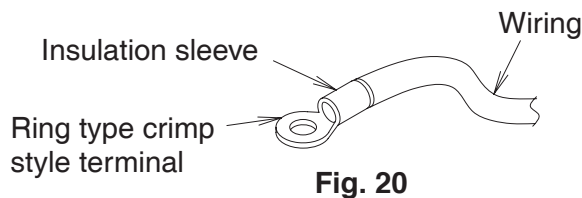

Fig. 20

- Connect the terminal as shown in **Fig. 21**.
- Do not carry out soldering finish when stranded wires are used. (Otherwise, the loosening of wires may result in abnormal heat radiation.)

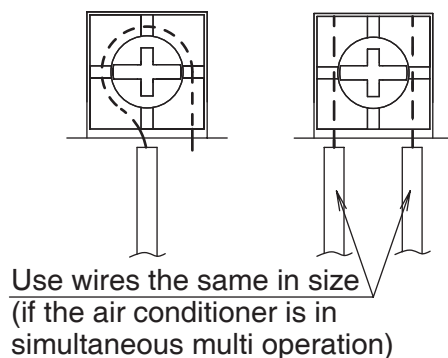

Fig. 21

(Abnormal heating may occur if the wirings are not tightened securely.)

- Use the required wirings, connect them securely and fix these wirings securely so that external force may not apply to the terminals.
- Use a proper screw driver for tightening the terminal screws.
If an improper screw driver is used, it may damage the screw head and a proper tightening cannot be carried out.
- If a terminal is over tightened, it may be damaged.
Refer to the table shown below for tightening torque of terminals.

Table 3

	Tightening torque (N·m)
Terminal block for remote controller and transmission wirings	0.88 ± 0.08
Terminal for power supply	1.47 ± 0.14
Earth terminal	1.47 ± 0.14

- Do not carry out soldering finish when stranded wirings are used.

⚠ WARNING

- When wiring, form the wirings orderly so that the control box lid can be securely fastened. If the control box lid is not in place, the wirings may come out or be sandwiched by the box and the lid and cause electric shocks or a fire.

Precautions to be taken for power supply wiring

Use a round crimp-style terminal for connection to the power supply terminal block. In case it cannot be used due to unavoidable reasons, be sure to observe the following instructions.

Be sure to peel off the sheath of power supply wiring more than 40 mm. (Refer to Fig. 22)

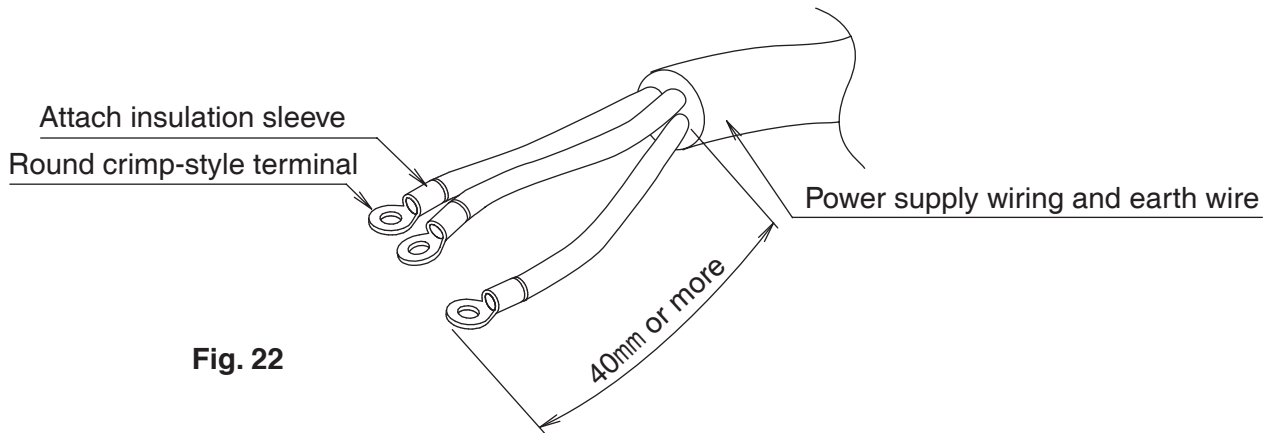

Fig. 22

- For remote controller wiring, refer to the “INSTALLATION MANUAL OF REMOTE CONTROLLER.” attached to the remote controller.
- **Never connect power supply wiring to the terminal block for remote controller. A mistake of the sort could damage the entire system.**
- Use only specified wire and tightly connect wires to terminals. Be careful wires do not place external stress on terminals. Keep wiring in neat order and so as not to obstruct other equipment such as popping open the control box cover. Make sure the cover closes tight. Incomplete connections could result in overheating, and in worse case, electric shock or fire.

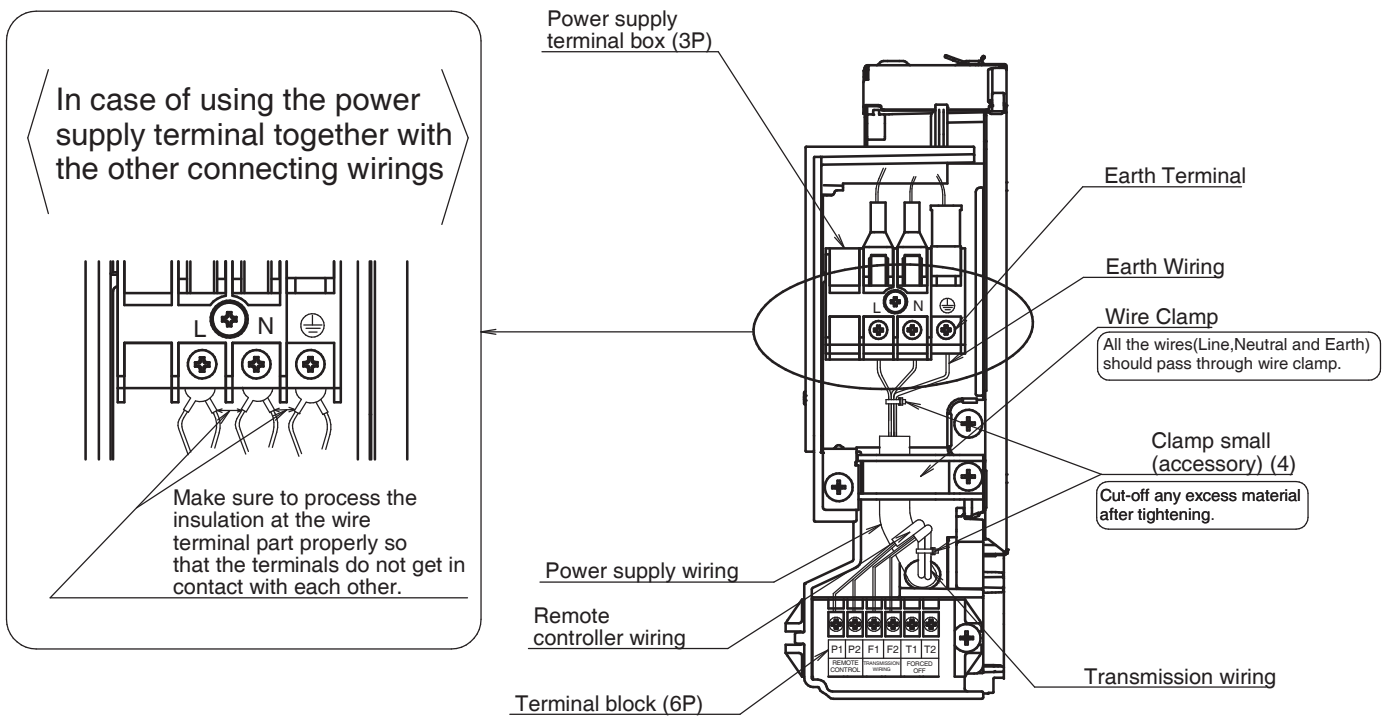

Fig. 23

CAUTION

- Be sure to attach the sealing material and putty (field supplied) to hole of wiring to prevent the infiltration of water as well as any insects and other small creatures from outside. Otherwise a short-circuit may occur inside the control box.
- When clamping the wirings, be sure no pressure is applied to the wire connections by using the included clamp to make appropriate clamps. Also, when wiring, make sure the cover on the control box fits snugly by arranging the wirings neatly and attaching the service cover firmly. When attaching the service cover, make sure no wirings get caught in the edges. Pass wiring through the wiring through holes to prevent damage to them.
- Make sure the remote controller wiring, and transmission wire the wiring between the units, and other electrical wiring do not pass through the same locations outside the machine, separating them by at least 50mm, otherwise electrical noise (external static) could cause mistaken operation or breakage.
- Use only specified wire and tightly connect wires to terminals. Be careful wires do not place external stress on terminals. Keep wiring in neat order and so as not to obstruct other equipment such as popping open the service cover. Make sure the cover closes tight. Incomplete connections could result in overheating, and in worse case, electric shock or fire.

8-2 WIRING EXAMPLE

- Fit the power supply wiring of each unit with a switch and fuse as shown in the drawing.

COMPLETE SYSTEM EXAMPLE (3 systems)

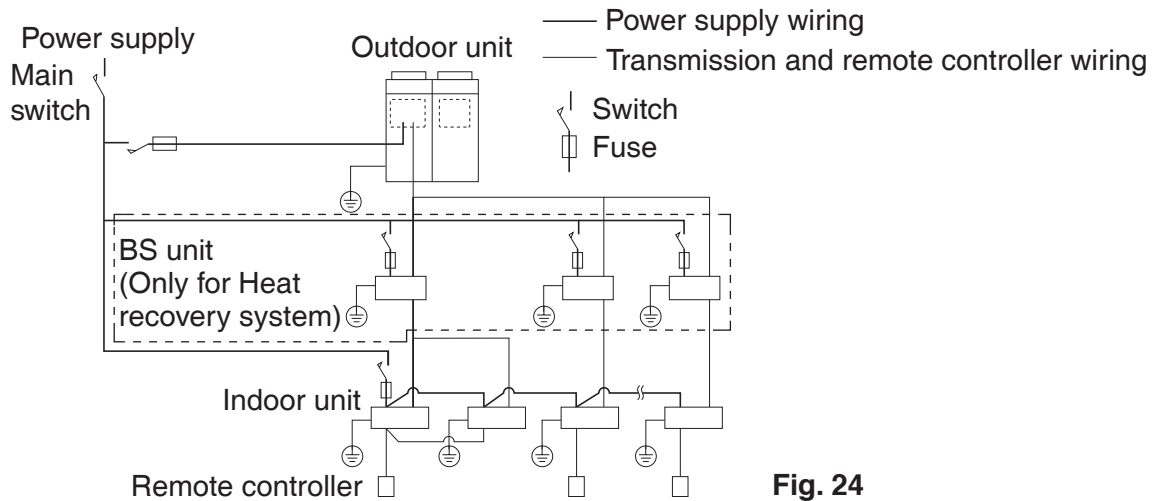

Fig. 24

1. When using 1 remote controller for 1 indoor unit. (Normal operation)

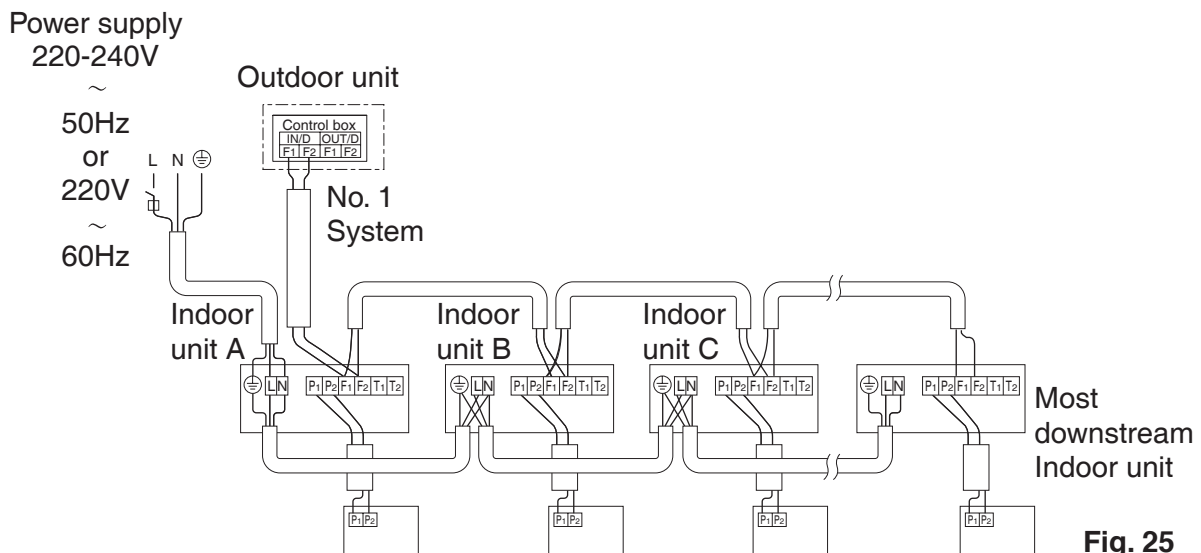
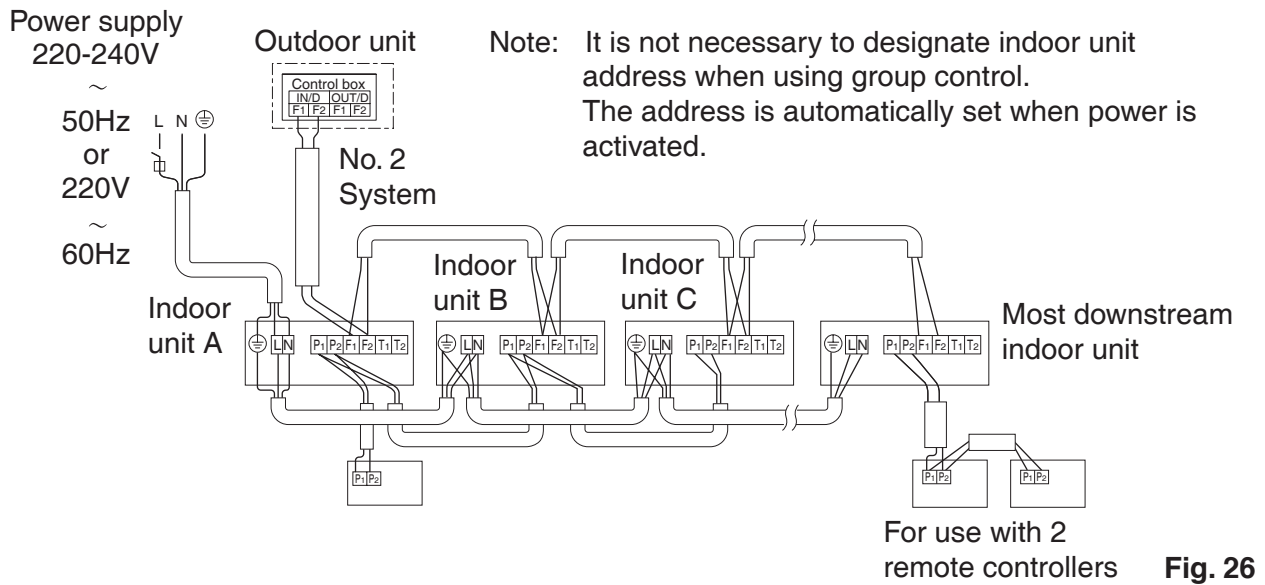
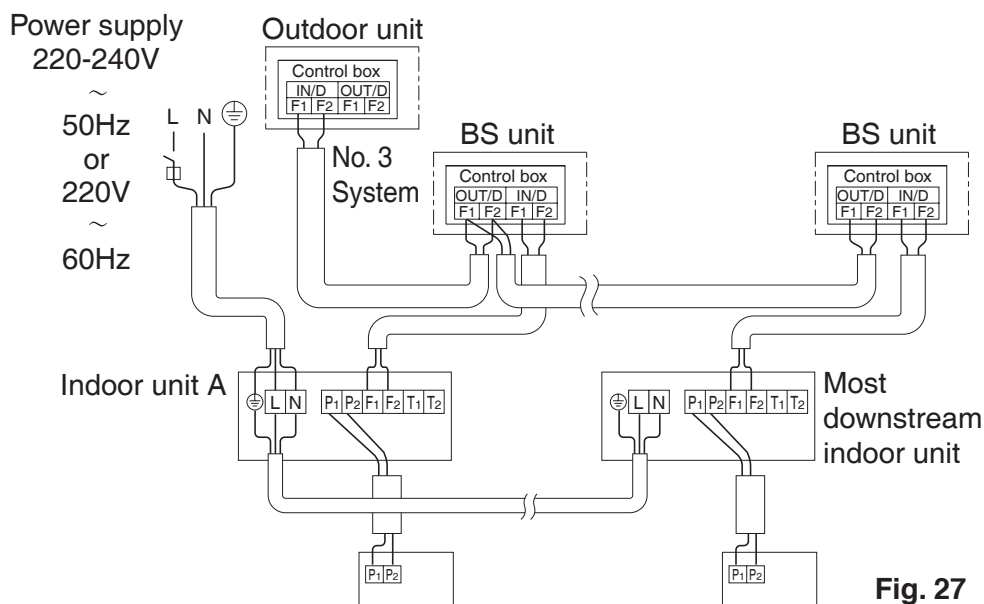

Fig. 25

2. For group control or use with 2 remote controllers



3. When including BS unit



[PRECAUTIONS]

1. All transmission wiring except for the remote controller wires is polarized and must match the terminal symbol.
2. A single switch can be used to supply power to units on the same system. However, branch switches and branch circuit breakers must be selected carefully.
3. Do not earth the equipment on gas pipes, water pipes or lightning rods, or cross earth with telephones. Improper earthing could result in electric shock.

8-3 CONTROL BY 2 REMOTE CONTROLLERS (CONTROLLING 1 INDOOR UNIT BY 2 REMOTE CONTROLLERS)

- When using 2 remote controllers, one must be set to “MAIN” and the other to “SUB”.

MAIN/SUB CHANGEOVER

- (1) Insert a ⊖ screwdriver into the recess between the upper and lower part of remote controller and, working from the 2 positions, pry off the upper part. The remote controller PC board is attached to the upper part of the remote controller. (Refer to Fig. 28)

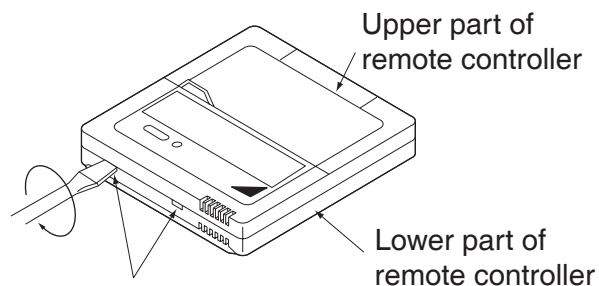

Insert the screwdriver here and gently work off the upper part of the remote controller. Fig. 28

- (2) Turn the **main/sub changeover** switch on one of the two remote controller PC boards to “S”. (Leave the switch of the other remote controller set to “M”.) (Refer to Fig. 29)

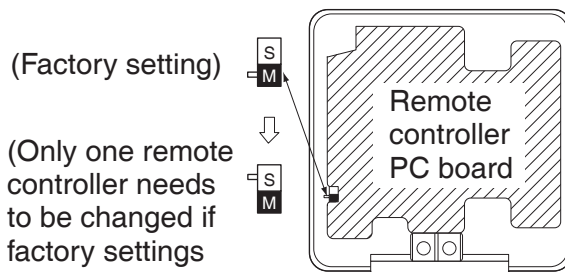

Fig. 29

Wiring Method (See “7.ELECTRIC WIRING WORK”)

- (3) Remove the service cover.
 (4) **Add remote control 2 (slave) to the terminal block (6P) for remote controller (P₁, P₂) in the control box.** (There is no polarity.) (Refer to Fig. 26 and section 7-3 for the wiring size.)

8-4 COMPUTERISED CONTROL (FORCED OFF AND ON/OFF OPERATION)

- (1) Wire specifications and how to perform wiring
- Connect the input from outside to terminals T1 and T2 of the terminal block (6P) for remote controller.

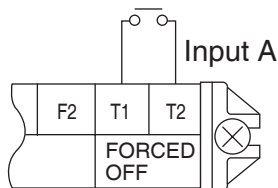

Fig. 30

Wire specification	Sheathed vinyl cord or cable (2 wire)
Gauge	0.75 - 1.25 mm ²
Length	Max. 100 m
External terminal	Contact that can ensure the minimum applicable load of 15V DC, 1 mA.

- (2) Actuation

- The following table explains FORCED OFF and ON/OFF OPERATIONS in response to Input A.

FORCED OFF	ON/OFF OPERATION
Input “ON” stops operation (impossible by remote controllers).	Input OFF → ON turns ON unit.
Input OFF enables control by remote controller.	Input ON → OFF turns OFF unit.

- (3) How to select FORCED OFF and ON/OFF OPERATION

- Turn the power on and then use the remote controller to select operation.

8-5 CENTRALIZED CONTROL

- For centralized control, it is necessary to designate the group No. For details, refer to the manual of each optional controllers for centralized control.

9. FIELD SETTINGS

(1) Make sure the service covers are closed on the indoor and outdoor units.

(2) Field settings must be made from the remote controller and in accordance with installation conditions.

- Settings can be made by changing the “Mode No”, “FIRST CODE NO.” and “SECOND CODE NO.”.
 - The “Field Settings” included with the remote control lists the order of the settings and method of operation.
- *Setting is made in all units in a group. To set for individual indoor units or to check the setting, use the mode Nos. (with “2” in upper digit) in parentheses ().

9-1 SETTING AIR FILTER SIGN

- Remote controllers are equipped with liquid crystal display air filter signs to display the time to clean air filters.
- Change the SECOND CODE NO. according to Table 4 depending on the amount of dirt or dust in the room. (SECOND CODE NO. is factory set to “01” for air filter contamination-light)

Table 4

Setting	Spacing time of display air filter sign	Mode No.	FIRST CODE NO.	SECOND CODE NO.
Air filter contamination-light	Approx. 200 hrs	10 (20)	0	01
Air filter contamination-heavy	Approx. 100 hrs			02

9-2 SETTING AIR FLOWRATE INCREASE MODE

- It is possible to raise set airflow (HIGH and LOW) from the field. Change the SECOND CODE NO. as shown in Table 5 to suit your needs. (SECOND CODE NO. is factory set to “01” for Standard.)

Table 5

Setting	Mode No.	FIRST CODE NO.	SECOND CODE NO.
Standard	13 (23)	0	01
A little increase			02
Increase			03

<When using wireless remote controllers>

- When using wireless remote controllers, wireless remote controller address setting is necessary. Refer to the installation manual attached to the wireless remote controller for setting instructions.
 - Set the remote controller to the field set mode. For details, refer to the “HOW TO SET IN THE FIELD”, in the remote controller manual.
 - When in the field set mode, select mode No. 12, then set the first code (switch) No. to “1”. Then set second code (position) No. to “01” for FORCED OFF and “02” for ON/OFF OPERATION. (FORCED OFF at factory set) **(Refer to Fig. 31)**

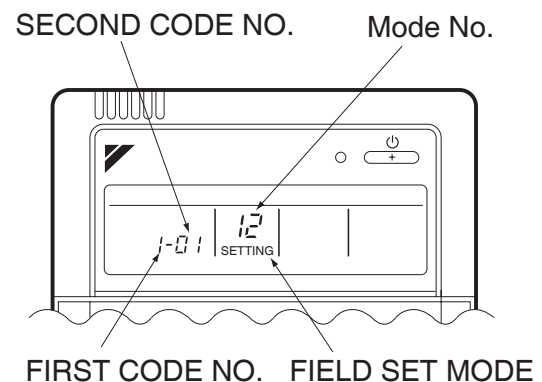

Fig. 31

10. TEST RUN

Make sure the service covers are closed on the indoor and outdoor units.

Refer to the installation manual of the outdoor unit.

- The operation lamp of the remote controller will flash when an malfunction occurs. Check the malfunction code on the liquid crystal display to identify the point of trouble. An explanation of malfunction codes and the corresponding trouble is provided in the installation manual of the outdoor unit or the service manual. If any of the items in Table 6 are displayed, there may be a problem with the wiring or power, so check the wiring again.

Table 6

Remote controller display	Content
“  ” is lit up	<ul style="list-style-type: none"> • There is a short circuit at the FORCED OFF terminals (T1, T2).
“U4” is lit up “UH” is lit up	<ul style="list-style-type: none"> • The power on the outdoor unit is off. • The outdoor unit has not been wired for power supply. • Incorrect wiring for the transmission wiring and/or FORCED OFF wiring. • The branch wiring is cut.
No display	<ul style="list-style-type: none"> • The power on the indoor unit is off. • The indoor unit has not been wired for power supply. • Incorrect wiring for the remote controller wiring, the transmission wiring, and/or the FORCED OFF wiring. • The remote controller wiring is cut.

- In order to protect the indoor unit, instruct the customer not to operate the air conditioner until the interior work is completed if the interior work has not been finished at the end of the test run. (If the air conditioner is operated, substances discharged from the paint, adhesive, etc. can contaminate the indoor unit, and they may cause splashing or leakage of water.)

NOTE

- After the test run is finished, check the items listed in “**b. Items to be checked at time of delivery**”.

PROTECT THE ENVIRONMENT FROM E-WASTE (GUIDELINES)

Meaning of E-waste under E-waste (Management) Rules, 2022 (E-waste Rules) Waste electrical and electronic equipment, whole or in part of reject from their manufacturing and repair process , which are intended to be discarded. Our product is RoHS compliant.

**Don't dump Electrical and Electronic Products in Garbage Bins****DO'S & DONT'S**

DO'S	
Run and maintain the air conditioner as per the instructions given in the operation / instruction manual	✓
Ensure that an authorised person repairs your air conditioner	✓
Call our local authorised dealer or our toll free number to dispose your air conditioner	✓
Contact an authorised dealer in case of installation or de-installation	✓
Consult our local authorised dealer or our toll free number on the life span of the air conditioner	✓
DONT'S	
Do not try to repair your air conditioner on your own	✗
Do not sell or dispose your air conditioner or parts to an unauthorised Kabbadi wala / Scrap Dealer / Ragpickers	✗
Do not dismantle your air conditioner on your own	✗
Do not get your air conditioner or any parts repaired by an unauthorised person	✗
Do not dispose off the E-waste in landfills	✗
Do not use the air conditioner as furniture after its use	✗

Customer Contact Center : 011-4031 9300/1860-180-3900

For further information visit us at www.daikinindia.com

Wiring Diagram

INDOOR UNIT	
A1P	PRINTED CIRCUIT BOARD
C18,C19	CAPACITOR
F1U	FUSE(T, 3.15AH, 250V)
X23A	CONNECTOR (FOR CAPACITY)
HAP	LIGHT EMITTING DIODE (SERVICE MONITOR GREEN)
M1F	MOTOR(INDOOR FAN)
M1S	MOTOR(SWING FLAP)
PS	SWITCHING POWER SUPPLY
R1T	THERMISTOR(AIR)
R2T	THERMISTOR(COIL LIQUID PIPE)
R3T	THERMISTOR(COIL GAS PIPE)
DB1	DIODE BRIDGE
X1M	TERMINAL BLOCK(CONTROL)
X2M	TERMINAL BLOCK(POWER)
Y1E	ELECTRONIC EXPANSION VALVE

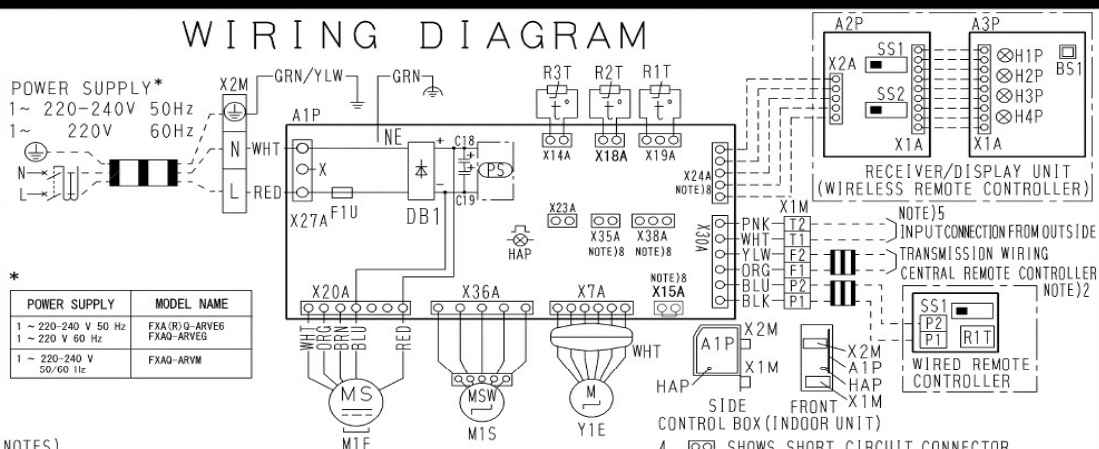

POWER SUPPLY	MODEL NAME
1 ~ 220-240 V 50 Hz	FXA(R)Q-ARVE6
1 ~ 220 V 60 Hz	FXAQ-ARVE6
1 ~ 220-240 V 50/60 Hz	FXAQ-ARVM

- NOTES)
- : TERMINAL
 : CONNECTOR
 : PROTECTIVE EARTH(SCREW)
 - : FIELD WIRING
 : CONNECTOR
 : NOISELESS EARTH
 - IN CASE USING CENTRAL REMOTE CONTROLLER, CONNECT IT TO THE UNIT IN ACCORDANCE WITH THE ATTACHED INSTALLATION MANUAL.
 - SYMBOLS SHOW AS FOLLOWS: RED:RED WHT:WHITE GRN:GREEN PNK:PINK YLW:YELLOW BLK:BLACK ORG:ORANGE BLU:BLUE BRN:BROWN

- SHOWS SHORT CIRCUIT CONNECTOR.
- WHEN CONNECTING THE INPUT WIRES FROM OUTSIDE, FORCED OFF OR ON/OFF CONTROL OPERATION CAN BE SELECTED BY REMOTE CONTROLLER. IN DETAILS, REFER TO THE INSTALLATION MANUAL ATTACHED TO THE UNIT.
- REMOTE CONTROLLER MODEL VARIES ACCORDING TO THE COMBINATION SYSTEM. CONFIRM ENGINEERING DATA AND CATALOGS, ETC. BEFORE CONNECTING.
- CONFIRM THE METHOD OF SETTING THE SELECTOR SWITCH(SS1, SS2) OF WIRED REMOTE CONTROLLER AND WIRELESS REMOTE CONTROLLER BY INSTALLATION MANUAL AND ENGINEERING DATA, ETC.
- X24A, X35A, X38A AND X15A ARE CONNECTED WHEN THE OPTIONAL ACCESSORIES ARE USED.

RECEIVER/DISPLAY UNIT(ATTACHED TO WIRELESS REMOTE CONTROLLER)	
A2P	PRINTED CIRCUIT BOARD
A3P	PRINTED CIRCUIT BOARD
BS1	PUSH BUTTON(ON/OFF)
H1P	LIGHT EMITTING DIODE(ON-RED)
H2P	LIGHT EMITTING DIODE(TIMER-GREEN)
H3P	LIGHT EMITTING DIODE(FILTER SIGN-RED)
H4P	LIGHT EMITTING DIODE(DEFROST-ORANGE)
SS1	SELECTOR SWITCH(MAIN/SUB)

	CONNECTOR FOR OPTIONAL PARTS
SS2 SELECTOR SWITCH (WIRELESS ADDRESS SET)	X24A CONNECTOR(WIRELESS REMOTE CONTROLLER)
WIRED REMOTE CONTROLLER	X35A CONNECTOR(GROUP CONTROL ADAPTOR)
R1T THERMISTOR(AIR)	X38A CONNECTOR(ADAPTOR FOR MULTI TENANT)
SS1 SELECTOR SWITCH(MAIN/SUB)	X15A CONNECTOR(FOR FLOAT SWITCH)

3D118250-1F

Applicable Model :- FXARQ20ARVE6,FXARQ25ARVE6,FXARQ32ARVE6,FXARQ40ARVE6,FXARQ50ARVE6 & FXARQ63ARVE6.

