

CBW SERVICE UNIT NON-INVERTER COMPATIBLE MODEL LIST

Existing Models			Service Models	
Models	Piping		Models	Piping
FTC60PRV16	Gas pipe Φ 12.7 Liquid pipe Φ 6.4		JOBU127TV16T	Gas pipe Φ 12.7 Liquid pipe Φ 6.4
FTEL50NRV16				
FTC50RRV161				
FTC50RRV162				
FTC50RRV162A				
FTC60QRV16				
FTC60QRV161				
FTC60RRV161				
FTC60RRV162				
FTC60RRV162A				
FTF60RRV161				
FTUF60RRV161				
FTC50PRV16				
FTQ50PRV16				
FTQ60PRV16				
FTC50QRV16				
FTC50QRV161				
FTF50RRV161				
FTQ50QRV16				
FTQ50RRV162				
FTQ60QRV16				
FTQ60RRV162				
FTUF50RRV161				
FTEL50PRV16	Gas pipe Φ 15.9 Liquid pipe Φ 6.4		JOBU159TV16T	Gas pipe Φ 15.9 Liquid pipe Φ 6.4
FTEL60PRV16				
FTF50PRV16				
FTF50QRV16				
FTF50QRV161				
FTF60PRV16				
FTF60QRV16				
FTE50NRV16				
FTE60NRV16				
FTEL60NRV16				

Wiring Diagram

WIRING DIAGRAM

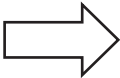
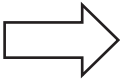
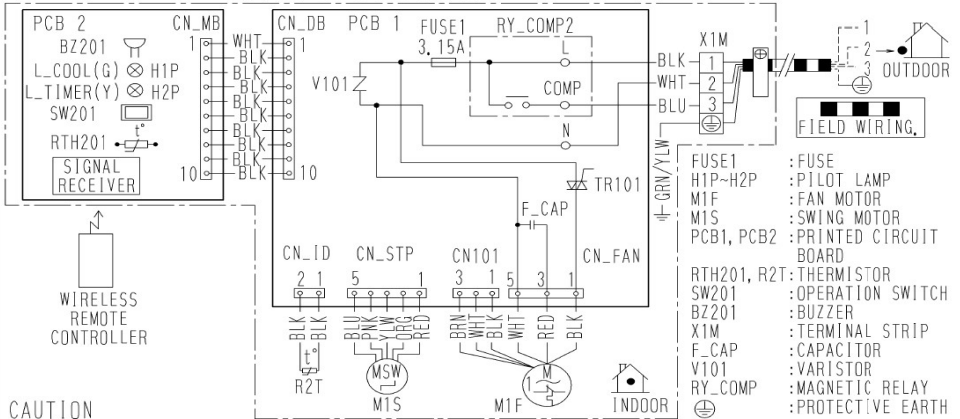

- FUSE1 : FUSE
- H1P-H2P : PILOT LAMP
- M1F : FAN MOTOR
- M1S : SWING MOTOR
- PCB1, PCB2 : PRINTED CIRCUIT BOARD
- RTH201, R2T : THERMISTOR
- SW201 : OPERATION SWITCH
- BZ201 : BUZZER
- X1M : TERMINAL STRIP
- F_CAP : CAPACITOR
- V101 : VARISTOR
- RY_COMP : MAGNETIC RELAY
- ⊕ : PROTECTIVE EARTH

CAUTION
 NOTE THAT OPERATION WILL RESTART AUTOMATICALLY IF THE MAIN POWER SUPPLY IS TURNED OFF AND THEN BACK ON AGAIN.

3D077596-1C

Applicable Model :- JOBU127TV16T & JOBU159TV16T.