

**DAIKIN**

# INSTALLATION MANUAL

## **VRV** SYSTEM Inverter Air Conditioners

MODELS:- Ceiling-mounted Duct type

**FXMQ20PBV36****FXMQ50PBV36****FXMQ125PBV36****FXMQ25PBV36****FXMQ63PBV36****FXMQ140PBV36****FXMQ32PBV36****FXMQ80PBV36****FXMQ40PBV36****FXMQ100PBV36**

Installation manual :- Pg.No. 1-13  
Operation manual :- Pg.No. 14-16

### 1. SAFETY PRECAUTIONS

Please read these "SAFETY PRECAUTIONS" carefully before installing air conditioning unit and be sure to install it correctly. After completing installation, conduct a trial operation to check for faults and explain to the customer how to operate the air conditioner and take care of it with the aid of the operation manual. Ask the customer to store the manual for future reference.

**This air conditioner comes under the term "appliances not accessible to the general public".**

#### Safety precaution

This unit is a class A product. In a domestic environment this product may cause radio interference in which case the user may be required to take adequate measures.

Meaning of WARNING and CAUTION notices

 **WARNING** ..... Failure to follow these instructions properly may result in personal injury or loss of life.

 **CAUTION** ..... Failure to observe these instructions properly may result in property damage or personal injury, which may be serious depending on the circumstances.

#### **CAUTION**

- Ask your dealer or qualified personnel to carry out installation work.  
Do not attempt to install the air conditioner yourself. Improper installation may result in water leakage, electric shocks or fire.
- Install the air conditioner in accordance with the instructions in this installation manual.  
Improper installation may result in water leakage, electric shocks or fire.
- Consult your local dealer regarding what to do in case of refrigerant leakage. When the air conditioner is to be installed in a small room, it is necessary to take proper measures so that the amount of any leaked refrigerant does not exceed the concentration limit in the event of a leakage. Otherwise, this may lead to an accident due to oxygen depletion.

- Be sure to use only the specified accessories and parts for installation work.  
Failure to use the specified parts may result in the unit falling, water leakage, electric shocks or fire.
- Install the air conditioner on a foundation strong enough to withstand the weight of the unit.  
A foundation of insufficient strength may result in the equipment falling down and causing injury.
- Carry out the specified installation work after taking into account strong winds, typhoons or earthquakes.  
Failure to do so during installation work may result in the unit falling and causing accidents.
- Make sure that a separate power supply circuit is provided for this unit and that all electrical work is carried out by qualified personnel according to local laws and regulations and this installation manual.  
An insufficient power supply capacity or improper electrical construction may lead to electric shocks or fire.
- Make sure that all wiring is secured, the specified wires are used, and that there is no strain on the terminal connections or wires.  
Improper connections or securing of wires may result in abnormal heat build up or fire.
- When wiring the power supply and connecting the remote controller wiring and transmission wiring, position the wires so that the el. compo. box lid can be securely fastened.  
Improper positioning of the el. compo. box lid may result in electric shocks, fire or the terminals overheating.
- If refrigerant gas leaks during installation, ventilate the area immediately.  
Toxic gas may be produced if the refrigerant comes into contact with fire.
- After completing installation, check for refrigerant gas leakage.  
Toxic gas may be produced if the refrigerant gas leaks into the room and comes into contact with a source of fire, such as a fan heater, stove or cooker.
- Be sure to switch off the unit before touching any electrical parts.
- Be sure to earth the air conditioner.  
Do not earth the unit to a utility pipe, lightning conductor or telephone earth lead. Imperfect earthing may result in electric shocks or fire.  
A high surge current from lightning or other sources may cause damage to the air conditioner.
- Be sure to install an earth leakage breaker.  
Failure to install an earth leakage breaker may result in electric shocks or fire.



## CAUTION

- While following the instructions in this installation manual, install drain piping to ensure proper drainage and insulate piping to prevent condensation. Improper drain piping may result in indoor water leakage and property damage.
- Install the indoor and outdoor units, power cord and connecting wires at least 1 meter away from televisions or radios to prevent picture interference and noise. (Depending on the incoming signal strength, a distance of 1 meter may not be sufficient to eliminate noise.)
- Remote controller (wireless kit) transmitting distance can be shorter than expected in rooms with electronic fluorescent lamps (inverter or rapid start types). Install the indoor unit as far as possible from fluorescent lamps.
- Do not install the air conditioner in the following locations:
  1. Where there is a high concentration of mineral oil spray or vapour (e.g. a kitchen).  
Plastic parts will deteriorate, parts may fall off and water leakage could result.
  2. Where corrosive gas, such as sulphurous acid gas, is produced.  
Corroding of copper pipes or soldered parts may result in refrigerant leakage.
  3. Near machinery emitting electromagnetic radiation.  
Electromagnetic radiation may disturb the operation of the control system and result in a malfunction of the unit.
  4. Where flammable gas may leak, where there is carbon fibre or ignitable dust suspensions in the air, or where volatile flammables such as paint thinner or gasoline are handled.  
Operating the unit in such conditions may result in fire.
- The air conditioner is not intended for use in a potentially explosive atmosphere.
- Do not touch the heat exchanger fins.  
Improper handling may result in injury.
- Be very careful about product transportation.  
Some products use PP bands for packaging. Do not use any PP bands for a means of transportation. It is dangerous.
- Safely dispose of the packing materials.  
Packing materials, such as nails and other metal or wooden parts, may cause stabs or other injuries.  
Tear apart and throw away plastic packaging bags so that children will not play with them. If children play with a plastic bag which was not torn apart, they face the risk of suffocation.
- Do not turn off the power immediately after stopping operation. Always wait at least 5 minutes before turning off the power. Otherwise, water leakage and trouble may occur.
- In a domestic environment this product may cause radio interference in which case the user may be required to take adequate measures.

Follow national standards for installation work.

## 2. BEFORE INSTALLATION

- **When moving the unit while removing it from the carton box, be sure to lift it by holding on to the four lifting lugs without exerting any pressure on other parts, especially, the refrigerant piping, drain piping, flanges and other resin parts.**
- Be sure to check the type of R410A refrigerant to be used before installing the unit. (Using an incorrect refrigerant will prevent normal operation of the unit.)
- The accessories needed for installation must be retained in your custody until the installation work is completed. Do not discard them!

- Decide upon a line of transport. Decide transportation medium.
- Leave the unit inside its packaging while moving, until reaching the installation site. Where unpacking is unavoidable, use a sling of soft material or protective plates together with a rope when lifting, to avoid damage or scratches to the unit.
- For the installation of outdoor unit, refer to the installation manual attached to the outdoor unit.
- Do not install or operate the unit in rooms mentioned below.
  - **Laden with mineral oil, or filled with oil vapor or spray like in kitchens. (Plastic parts may deteriorate which could eventually cause the unit to fall out of place, or could lead to leaks.)**
  - **Where corrosive gas like sulfurous gas exists. (Copper tubing and brazed spots may corrode which could eventually lead to refrigerant leaks.)**
  - **Where exposed to combustible gases and where volatile flammable gas like thinner or gasoline is used. (Gas in the vicinity of the unit could ignite.)**
  - **Where machines can generate electromagnetic waves. (Control system may malfunction.)**
  - **Where the air contains high levels of salt such as that near the ocean and where voltage fluctuates greatly such as that in factories. Also in vehicles or vessels.**
- This unit, both indoor and outdoor, is suitable for installation in a commercial and light industrial environment. If installed as a household appliance it could cause electromagnetic interference.

### 2-1 PRECAUTIONS

- Be sure to read this manual before installing the indoor unit.
- Entrust installation to the place of purchase or a qualified serviceman. Improper installation could lead to leaks and, in worse cases, electric shock or fire.
- Use only parts provided with the unit or parts satisfying required specifications. Unspecified parts could cause the unit to fall out of place, or could lead to leaks and, in worse cases, electric shock or fire.
- Be sure to mount an air filter (part to be procured in the field) in the suction air passage in order to prevent water leaking, etc.

### 2-2 ACCESSORIES

Check that the following accessories are provided and that each accessory is correct in amount. Refer to the Fig. 1 of this sheet.

#### [PRECAUTION]

The accessories are required for the installation of the air conditioner. Be sure to keep them until the installation work is completed

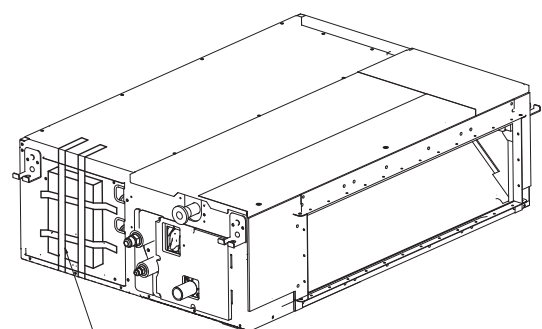

Installation &  
Operation Manual  
(1)-(11)

Fig. 1

Name	-	Insulation for fitting	Sealing pad	-	-	-
Quantity	1 each	1 each	-	-	-	-
Shape	 Metal clamp (1)	 Thin for liquid pipe (3)	 1 pc. Large (Dark grey) (5)	 9 Pc. Clamp (7)	 2 Pc. Wire sealing material (9)	 M4x8
	 Drain Hose(2)	 Thick for gas pipe (4)	 2 pc. Middle (Dark grey) (6)	 4 Pc. Washer fixing plate (8)	 2 Pc. Wire fixing bracket (10)	 2 Pc. Wire fixing screw (11)

Other Installation & Operation manual

**2-3 OPTIONAL ACCESSORIES**

- These are two types of remote controllers: wired and wireless. Select a remote controller according to customer request and install in an appropriate place.

Table 1

Remote controller	
Wired type	
Wireless type	Heat pump type
	Cooling only type

**NOTE**

- If you wish to use a remote controller that is not listed in Table 1, select a suitable remote controller after consulting catalogs and technical materials.

**FOR THE FOLLOWING ITEMS, TAKE SPECIAL CARE DURING CONSTRUCTION AND CHECK AFTER INSTALLATION IS FINISHED.**

**a. Items to be checked after completion of work**

Items to be checked	If not properly done, what is likely to occur.	Check
Are the indoor and outdoor unit fixed firmly?	The units may drop, vibrate or make noise.	
Was the installation of the outdoor unit completed?	The unit may malfunction or the components burn out.	
Is the gas leak test finished?	No cooling or heating.	
Is the unit fully insulated? (Refrigerant piping, drain piping, and duct)	Condensate water may drip.	
Does drainage flow smoothly?	Condensate water may drip.	
Does the power supply voltage conform to the indication on the name plate?	The unit may malfunction or the components burn out.	
Are wiring and piping correct?	The unit may malfunction or the components burn out.	
Is the air conditioner properly grounded?	Dangerous in case of current leakage.	
Is wiring size according to specifications?	The unit may malfunction or the components burn out.	
Is something blocking the air outlet or inlet of either the indoor or outdoor units?	No cooling or heating.	
Did you set the external static pressure?	No cooling or heating.	
Are refrigerant piping length and additional refrigerant charge noted down?	The refrigerant charge in the system is not clear.	
Did you check that no wiring connection screws were loose?	Electric shock or fire.	

Also review the “SAFETY PRECAUTIONS”.

**b. Items to be checked at the time of delivery**

Items to be checked	Check
Are you sure the el. compo. box lid, air filter, air inlet grille, and air outlet grille are mounted?	
Did you explain about operations while showing the operation manual to your customer?	
Did you deliver the operation manual along with the installation manual to the customer?	
Did you explain the customer the handling and cleaning methods of the field supplies (e.g., the air filter, air inlet grilles, and air outlet grille)?	
Did you deliver instruction manual, if any, for the field supplies to the customer?	

**c. Points for explanation about operations**

The items with  $\triangle$  WARNING and  $\triangle$  CAUTION marks in the instruction manual are the items pertaining to possibilities for bodily injury and material damage in addition to the general usage of the product. Accordingly, it is necessary that you make a full explanation about the described contents and also ask your customers to read the instruction manual.

**2-4 NOTE TO INSTALLER**

- Be sure to instruct customers how to properly operate the unit (especially cleaning filters, operating different functions, and adjusting the temperature) by having them carry out operations themselves while looking at the manual.

**3. SELECTING INSTALLATION SITE**

- Hold the hanging brackets in the case of moving the indoor and outdoor units at the time of and after opening the packages. Do not impose undue force on other parts, such as the refrigerant piping, drain piping, or flanges, in particular.
- Add heat insulation material to the indoor unit if the temperature above the ceiling is likely to exceed 30°C and a relative humidity of 80%.
- Make sure that the insulation material is made of glass wool or polyethylene foam, which has a minimum thickness of 10 mm, and can be accommodated in the opening on the ceiling.

(1) Select an installation site where the following conditions are fulfilled and that meets with your customer’s approval.

- A place where cool (warm) air is delivered to the entire room.
- Where nothing blocks the air passage.
- Where condensation can be properly drained.
- If supporting structural members are not strong enough to take the unit’s weight, the unit could fall out of place and cause serious injury.
- Where the false ceiling is not noticeably on an incline.
- Where there is no risk of flammable gas leakage.
- Where sufficient clearance for maintenance and service can be ensured. (Refer to Fig. 2-1)
- Where piping between indoor and outdoor units is possible within the allowable limit. (Refer to the installation manual of the outdoor unit.)

**CAUTION**

- Install the indoor and outdoor units, power supply wiring and connecting wires at least 1 meter away from televisions or radios in order to prevent image interference or noise. (Depending on the radio waves, a distance of 1 meter may not be sufficient enough to eliminate the noise.)
- In the case of the installation of a wireless remote controller, the transmission distance of the wireless remote controller may be shortened if the room has a fluorescent light of electronic lighting type (i.e., an inverter or rapid-start fluorescent light). Keep the distance between the receiver and the fluorescent light as far as possible.

(2) Use hanging bolts to install the indoor unit. Check that the place of installation withstands the weight of the indoor unit. Secure the hanging bolts with proper beams if necessary.

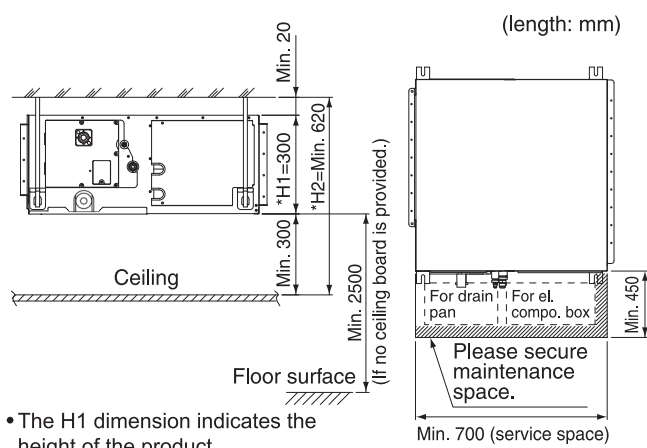

- The H1 dimension indicates the height of the product.
  - Determine the H2 dimension by maintaining a downward slope of at least 1/100 as specified in "7. DRAIN PIPING WORK".
- [Required installation place]  
The dimensions indicate the minimum required space of installation.

Fig. 2-1

**4. PREPARING BEFORE INSTALLATION**

(1) Check the positional relationship between the ceiling opening hole and the hanging bolt of the unit.

- For the maintenance, inspection, and other servicing purposes of the el. compo. box and drain pump, prepare one of the following service spaces.
  1. Inspection hatch 1, 2 (450 × 450) for the el. compo. box and a minimum space of 300 mm for the lower part of the product. (Refer to Fig. 2-2)
  2. Inspection hatch 1 (450 × 450) for the el. compo. box and inspection hatch 2 for the lower part of the product (see axial direction view A-1). (Refer to Fig. 2-3)
  3. Inspection hatch 3 for the lower part of the product and the lower part of the el. compo. box (see axial direction view A-2). (Refer to Fig. 2-3)

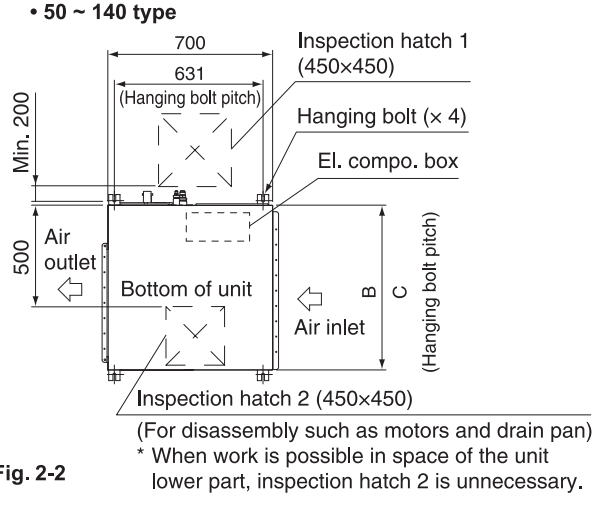
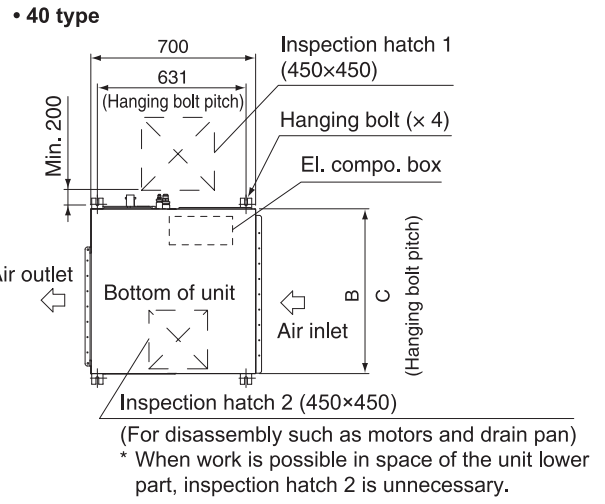
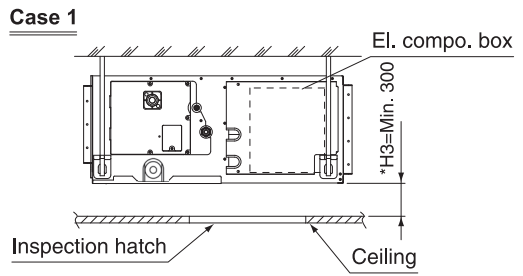

Fig. 2-2

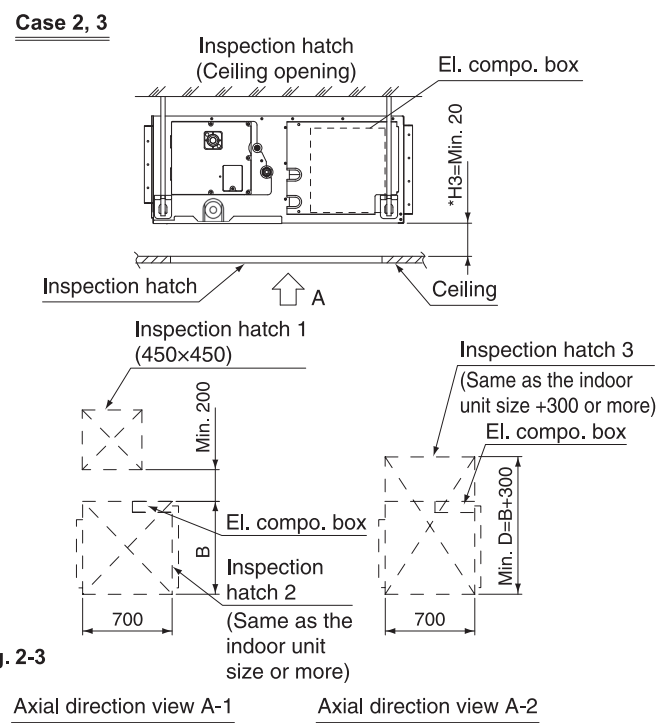

Fig. 2-3

• Determine the H3 dimension by maintaining a downward slope of at least 1/100 as specified in "7. DRAIN PIPING WORK".

Model	B	C	D
20•25•32•40 type	700	738	1000
50 • 63 • 80 type	1000	1038	1300
100 • 125 • 140 type	1400	1438	1700

(length: mm)

(2) Mount the canvas ducts to the air outlet and inlet so that the vibration of the air conditioner will not be transmitted to the duct or ceiling. Apply a sound absorbing material (insulation material) to the inner wall of the duct and vibration insulation rubber to the hanging bolts (refer to 8. DUCT WORK).

(3) Open installation holes (if the ceiling already exists).  
 • Open the installation holes on the ceiling. Lay the refrigerant piping, drain piping, power line, transmission wiring, and remote controller wiring for the piping and wiring connection port of the unit. In the case of the installation of a wireless remote controller, refer to the installation manual provided with the wireless remote controller.  
 Refer to **6. REFRIGERANT PIPING WORK**, **7. DRAIN PIPING WORK**, and **10. WIRING EXAMPLE AND HOW TO SET THE REMOTE CONTROLLER**.

• The ceiling framework may need reinforcement in order to keep the ceiling horizontal and prevent the vibration of the ceiling after the installation holes are opened. For details, consult your construction or interior contractor.

(4) Install the hanging bolts. Make sure that the hanging bolts are M10 in size.

• Use hole in anchors if the hanging bolts already exist; otherwise use embedded inserts and embedded foundation bolts so that they will withstand the weight of the unit. Adjust the distance to the ceiling surface in advance.

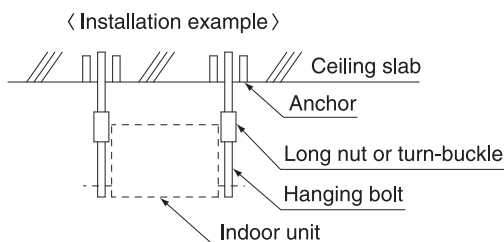

Note) All the above parts are field supplied.

## 5. INDOOR UNIT INSTALLATION

(It may be easier to install accessories (sold separately) before installing the indoor unit. Refer to the installation manuals provided to the accessories as well.)

Be sure to use the accessories and specified parts for installation work.

(1) Temporally install the indoor unit.  
 • Connect the hanging brackets to the hanging bolts. Be sure to use and tighten the nut and washer (procured in the field) for each hanging bracket from both upper and lower sides of the hanging bracket. (Refer to Fig. 3) At that time, the fall of the washer for the hanging bracket can be prevented if the washing fixing plate (8) is used.

### [Fixing hanging brackets]

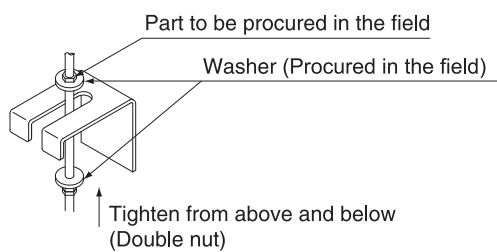

### [Fixing method of washers]

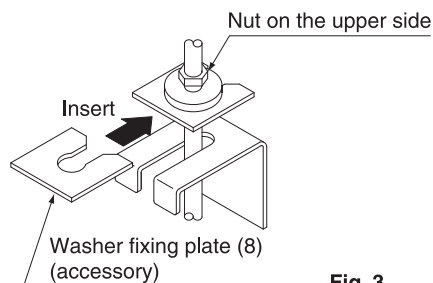

Fig. 3

### CAUTION

• During the installation work, perform the curing of the air outlet and protect the resin drain pan of the indoor unit from the intrusion of foreign substances, such as welding spatters.

Otherwise, water leakage may occur as a result of damage, such as hole damage, to the resin drain pan.

(2) Make adjustments so that the unit will be in the right position.  
 (3) Check the level of the unit.

(4) Remove the washer fixing plates for the falling prevention of the washers for the hanging brackets, tighten the nuts on the upper side, and securely fix the unit.

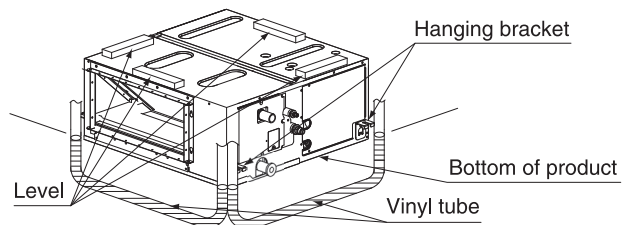

### CAUTION

• Use the level and check that the unit is installed horizontally.(4-directions)  
 • In the case of using a vinyl tube in place of the level, put the both edges of the vinyl tube in close contact with the bottom of the product to make levelness adjustment.  
 If the unit is installed at a slant with the drain pipe side set high, in particular, the float switch will not operate normally and water leakage may result.

## 6. REFRIGERANT PIPING WORK

• As for the refrigerant piping of the outdoor unit, refer to the installation manual provided to the outdoor unit.  
 • Perform heat insulation work on both gas piping and liquid piping, or otherwise water leakage may result. Use the insulation material that withstands a temperature of 120°C.

- Reinforce the insulation material for the refrigerant piping if the ambient temperature is high, or otherwise dew condensation may result on the surface of the insulation material.
- Make sure that the refrigerant is R410A before refrigerant piping work. If the refrigerant is different, the air conditioner will not operate normally.

**CAUTION**

This product uses new refrigerant (R410A) only. Be sure to keep the items on the right hand side and conduct the installation work.

- Use an appropriate pipe cutter and flare tool for R410A.
- When connecting the flare, apply ether oil or ester oil only to inner side of the flare.
- Be sure to use the flare nut provided with the unit. (Do not use a different flare nut (such as a type-1 flare nut), or otherwise refrigerant leakage may result.)
- Perform the curing of the piping with pinching or taping of the piping in order to prevent the intrusion of dirt, dust, and moisture into the piping.
- Be sure to use the specified type of refrigerant for the refrigeration cycle and do not contaminate the refrigerant with air.
- Ventilate the room in case of refrigerant leakage during installation work.

- The outdoor unit is filled with refrigerant.
- When connecting or disconnecting piping to or from the unit, be sure to use two spanners and two torque wrenches. (Refer to Fig. 4)

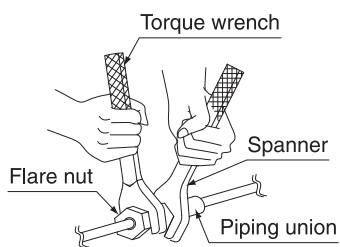

Fig. 4

- Refer to Table 2 for the processing dimensions of the flare.
- Use the flare nut provided with the unit.
- Apply ether oil or ester oil only to inner side of the flare and screw in the flare nut three to four turns first by hand at the time of connecting the flare nut. (Refer to Fig. 5)

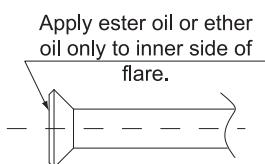

Fig. 5

- Refer to Table 2 for the corresponding tightening torque.

Table 2

Pipe size	Tightening torque	Flare dimensions A (mm)	Flare shape
φ 6.4	14.2 – 17.2N·m	8.7 – 9.1	
φ 9.5	32.7 – 39.9N·m	12.8 – 13.2	
φ 12.7	49.5 – 60.3N·m	16.2 – 16.6	
φ 15.9	61.8 – 75.4N·m	19.3 – 19.7	

**CAUTION**

- Do not excessively tighten the flare nut. Doing so will break the flare nut and refrigerant leakage may occur.
- Make sure that all parts around the flare are free of oil. The drain pan and the resin part may be deteriorated if oil is attached.

- If no torque wrenches are available, refer to Table 3 as a standard. When the flare nut is tightened with the spanner, the tightening torque should increase suddenly. Tighten the flare nut further for the corresponding angle shown in Table 3.

Table 3

Pipe size	Further tightening angle	Recommended arm length of tool
φ 6.4	60 to 90 degrees	Approx. 150mm
φ 9.5	60 to 90 degrees	Approx. 200mm
φ 12.7	30 to 60 degrees	Approx. 250mm
φ 15.9	30 to 60 degrees	Approx. 300mm

(2) On completion of installation work, check that there is no gas leakage.

(3) Refer to the illustration on the right hand side and be sure to perform heat insulation work on the piping joints after gas leakage checks. (Refer to Fig. 6)

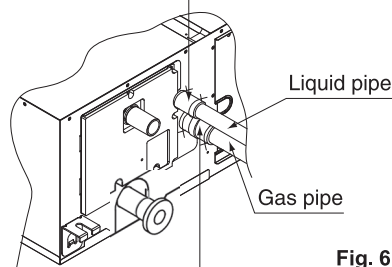
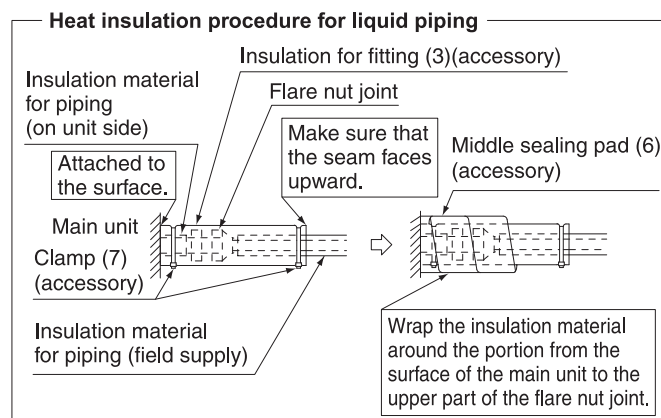
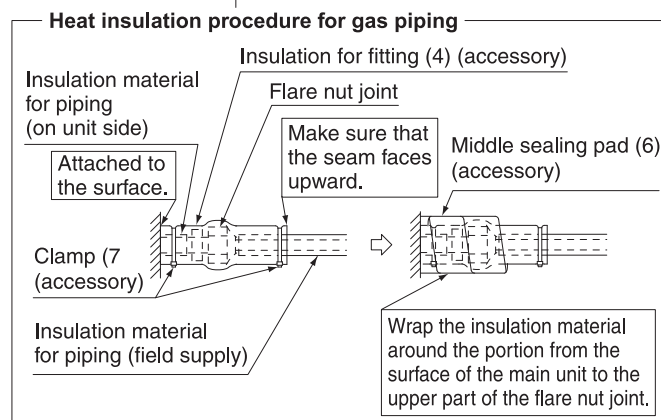

Fig. 6



- Use the insulation for fitting (3) and (4) provided to the liquid piping and gas piping, respectively, and conduct heat insulation work. (Tighten both edges of the insulation for fitting (3) and (4) for each joint with the clamp (7).)
- Make sure that the joint of the insulation for fitting (4) and (5) for the joint on the liquid piping and gas piping side faces upward.
- Wrap the middle sealing material (6) around the insulation for fitting (3) and (4) for the joint (flare nut part).

**CAUTION**

• **Be sure to perform the heat insulation of the local piping up to the piping joint.**  
If the piping is exposed, dew condensation may result. Furthermore, a burn may be caused if a human body comes in contact with the piping.

- Perform nitrogen substituent or apply nitrogen into the refrigerant piping (see NOTE 1) in the case of refrigerant piping brazing (see NOTE 2). Then perform the flare connection of the indoor unit. (Refer to Fig. 7)

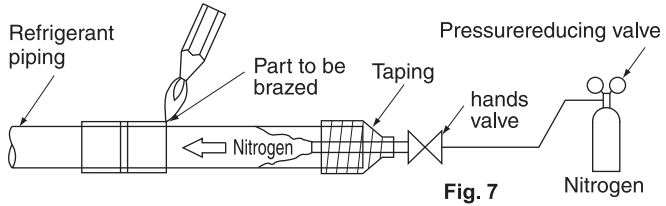

**CAUTION**

• **Do not use any antioxidant at the time of piping brazing.** The piping may be clogged with a residual antioxidant and parts may malfunction.

**NOTE**

1. At the time of brazing, set the pressure of nitrogen to approximately 0.02 MPa (close to the pressure of a breeze coming in contact with the cheek) with a decompression valve.
  2. Do not use flux at the time of brazing and connecting the refrigerant piping. Use a copper phosphorus brazing alloy (BCuP-2: JIS Z 3264/BCu 93P-710/795: ISO3677), which does not require flux, for brazing. (Flux has a bad influence on the refrigerant piping. Chlorine-based flux will cause piping corrosion. Furthermore, if it contains fluorine, the flux will deteriorate refrigerant oil.)
- As for the branching of the refrigerant piping or refrigerant, refer to the installation manual provided with the outdoor unit.

**4. REFRIGERANT PIPING WORK**

(1) Conduct drain piping work. **Check that the piping ensures proper draining.**

- Make sure that the diameter of the piping excluding the rising part is the same as or larger than the diameter of the connecting pipe (vinyl chloride pipe with an outer diameter of 32 mm and a nominal inner diameter of 25 mm).
- Make sure that the piping is short enough **with a downward slope of at least 1/100** and that there is no air bank formed. No drain trap is required.

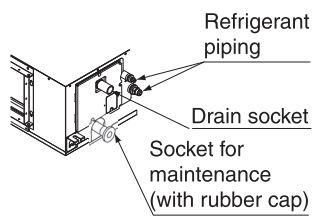

**CAUTION**

- The drain piping will be clogged with water and water leakage may result if the water is accumulated in the drain piping.
- Conduct drain up piping work if the gradient is insufficient.
- Attach a support bracket at 1 to 1.5 m intervals for the prevention of piping deflection.

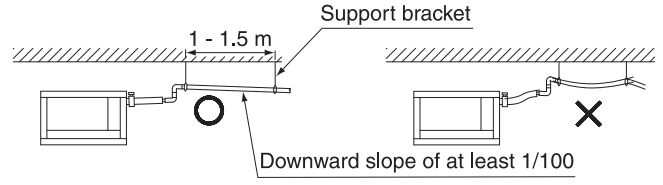

- Be sure to use the drain hose (2) and metal clamp (1). **Insert the drain hose (2) deep into the base of the drain socket, and securely fasten the metal clamp (1) within the taped part on the insertion front end of the hose.** Be sure to fasten the screw of the metal clamp (1) until the margin of the screw thread decreases to 4 mm or less.

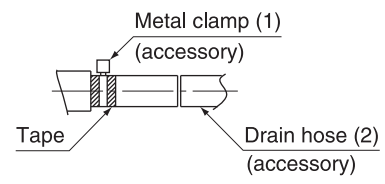

**NOTE**

- Be sure to follow the instructions as below.
- Do not connect the drain piping directly to a sewer that smells of ammonia. The ammonia in the sewer may reach through the drain piping and corrode the heat exchanger of the indoor unit.
  - Do not bend or twist the provided drain hose (2) in order not to impose excessive force on the hose. (Doing so may result in water leakage.)
  - Take the procedure shown in the following illustration to perform concentrated drain piping.

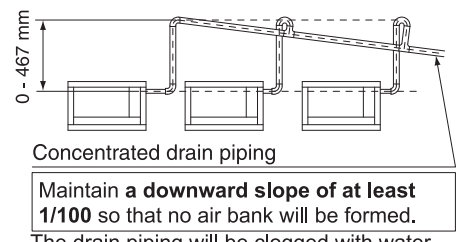

- Select the diameter of the concentrated drain piping to suit the capacity of equipment connecting to the concentrated drain piping (see the equipment design sheet).

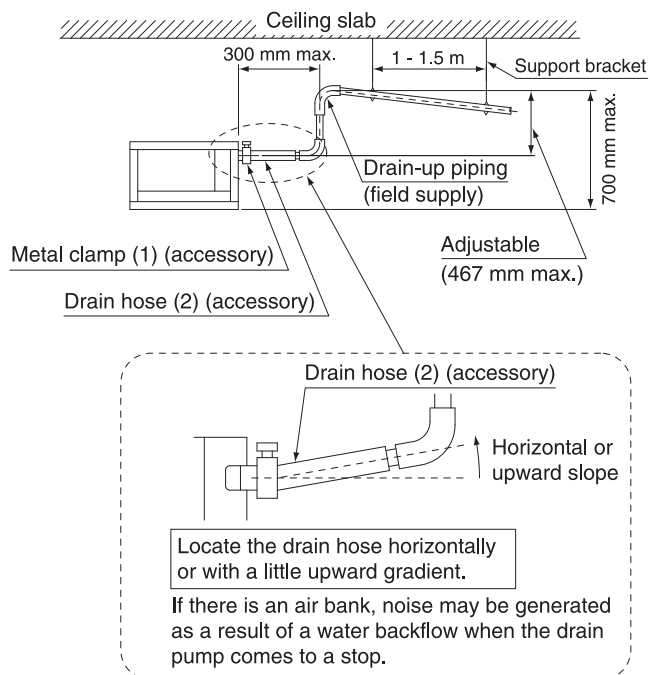

(2) Check the smooth draining of the piping on completion of the installation of the piping.

#### [Before electrical work]

### CAUTION

- A licensed electrical engineering technician must conduct electrical wiring work (including grounding work).
- If no licensed electrical engineering technician is available, take steps 3 and 4 after the test operation of the air conditioner is finished.

1. Remove the el. compo. box lid, and connect the single-phase electric wires to terminals L and N of the terminal block and the ground wire to the ground terminal. Perform wiring according to 10-1 CONNECTING POWER SUPPLY, GROUND, REMOTE CONTROLLER, AND TRANSMISSION WIRING in 10. WIRING EXAMPLE AND HOW TO SET THE REMOTE CONTROLLER.

### CAUTION

- In order to ensure not to impose tension on the wire connections, perform clamping securely with the provided clamp (7) specified in 3 in 10-1 CONNECTING POWER SUPPLY, GROUND, REMOTE CONTROLLER, AND TRANSMISSION WIRING.
2. Check that the el. compo. box lid is closed before turning the air conditioner ON.
  3. Provide **approximately one liter of water** gradually into the drain pan through the water inlet on the bottom of the drain socket or the outlet. Make sure that the water is not spilled onto the drain pump.
  4. The drain pump will operate with the power turned ON. Check that the pump drains water smoothly. (The drain pump will stop automatically in 10 minutes.) The drainage can be checked with the water level change in the drain pan through the water inlet.

### CAUTION

- Do not touch the drain pump. Otherwise, an electric shock may be received.
- Do not impose external force on the float switch. Otherwise, a failure may result.

5. On completion of the drainage check, shut off the power supply and disconnect the power supply line.
6. Put the el. compo. box lid to the original position.

#### [After electrical work]

- After completion of 8. DUCT WORK provide **approximately one liter of water** gradually into the drain pan through the water inlet on the bottom of the drain socket, and check that the water is drained while the air conditioner is in cooling operation according to 11. FIELD SETTING and 12. TEST OPERATION. Make sure that the water is not spilled onto the electric parts of the drain pump and others.

(3) Be sure to conduct heat insulation work on the following portions, or otherwise water leakage may occur as a result of dew condensation.

- Drain piping indoors
- Drain socket

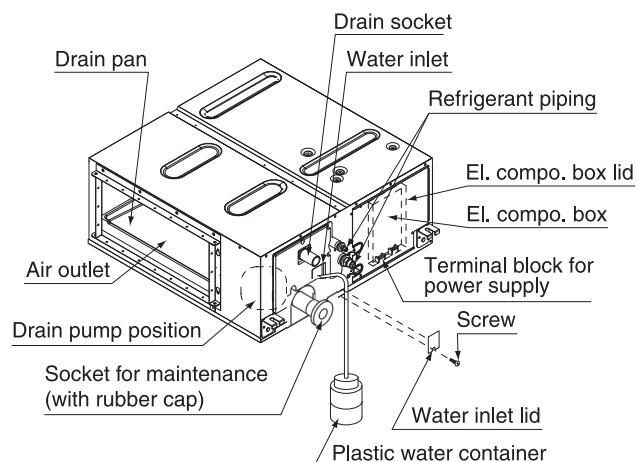

- On completion of the drainage check, refer to the following illustration, and use the provided large sealing pad (5) and heat insulate the metal clamp (1) and drain hose (2).

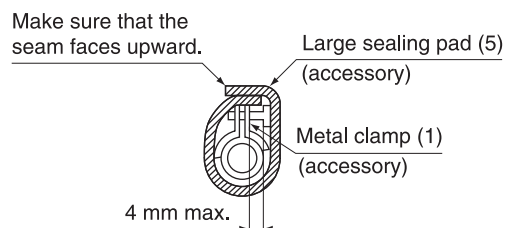

## 8. DUCT WORK

Pay utmost attention to the following items and conduct the duct work.

- Check that the duct will not be in excess of the setting range of external static pressure for the unit. (Refer to the technical datasheet for the setting range. Each model has each setting range of external static pressure.)



- Attach a canvas duct each to the air outlet and air inlet so that the vibration of the equipment will not be transmitted to the duct or ceiling. Use a sound absorbing material (insulation material) for the lining of the duct and apply vibration insulation rubber to the hanging bolts.
- At the time of duct welding, perform the curing of the duct so that the spatter will not come in contact with the drain pan for the filter.
- If the metal duct pass through a metal lath, wire lath, or metal plate of a wooden structure, separate the duct and wall electrically.
- Be sure to heat insulate the duct for the prevention of dew condensation. (Material: Glass wool or styrene foam; Thickness: 25 mm)
- Explain the operation and washing methods of the locally procured components (i.e., the air filter, air inlet grille, and air outlet grille) to the customer.
- Locate the air outlet grille on the indoor side for the prevention of drafts in a position where indirect contact with people.
- The air conditioner incorporates a function to adjust the fan to rated speed automatically. (11. FIELD SETTING)  
Therefore, do not use booster fans midway in the duct.

Connection method of ducts on air inlet and outlet sides.

- Connect the field supply duct in alignment with the inner side of the flange.
- Connect the flange and unit with the flange connection screw (field supply).
- Wrap aluminum tape around the flange and duct joint in order to prevent air leakage.

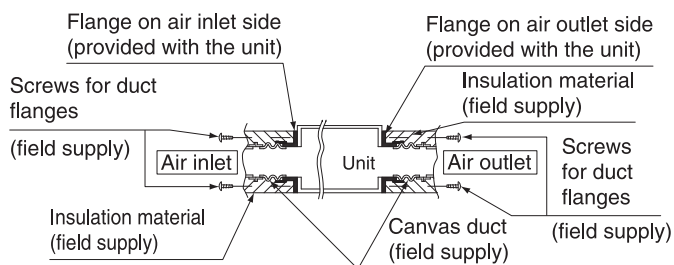

## CAUTION

Connect the flange and unit with the flange connection screw (Field supply) regardless of whether the duct is connected to the air inlet side.

## 9. ELECTRIC WIRING WORK

### 9-1 GENERAL INSTRUCTIONS

Shut off the power before starting any work.

- All field supplied parts and materials and electric works must conform to local codes.
- Use copper wire only.
- For electric wiring work, refer to also "Wiring diagram" attached to the el. compo. box lid.
- For remote controller wiring details, refer to the installation manual attached to the remote controller.
- All wiring must be performed by an authorized electrician.
- This system consists of multiple indoor units. Mark each indoor unit as unit A, unit B..., and be sure the terminal board wiring to the outdoor unit and BS unit are properly matched. If wiring and piping between the outdoor unit and an indoor unit are mismatched, the system may cause a malfunction.
- A circuit breaker capable of shutting down power supply to the entire system must be installed.

- Refer to the installation manual attached to the outdoor unit for the size of power supply wiring connected to the outdoor unit, the capacity of the circuit breaker and switch, and wiring instructions.
- Be sure to ground the air conditioner.
- Do not connect the ground wire to gas and water pipes, lightning rods, or telephone ground wires.
  - Gas pipes : might cause explosions or fire if gas leaks.
  - Water pipes : no grounding effect if hard vinyl piping is used.
  - Telephone ground wires or lightning rods : might cause abnormally high electric potential in the ground during lighting storms.

### 9-2 ELECTRIC CHARACTERISTICS

Model	Units			Power supply		Fan motor	
	Hz	Volts	Voltage range	MCA	MFA	kW	FLA
FXMQ20PBV36	50	230	Max. 264 Min. 198	0.6	16	0.09	0.5
FXMQ25PBV36				0.6	16	0.09	0.5
FXMQ32PBV36				0.6	16	0.09	0.5
FXMQ40PBV36				1.4	16	0.140	1.1
FXMQ50PBV36				1.6	16	0.350	1.3
FXMQ63PBV36				1.8	16	0.350	1.4
FXMQ80PBV36				2.3	16	0.350	1.8
FXMQ100PBV36				2.9	16	0.350	2.3
FXMQ125PBV36				3.4	16	0.350	2.7
FXMQ140PBV36				3.4	16	0.350	2.7

MCA: Min. Circuit Amps (A); MFA: Max. Fuse Amps (A)

kW: Fan Motor Rated Output (kW); FLA: Full Load Amps (A)

### 9-3 SPECIFICATIONS FOR FIELD SUPPLIED FUSES AND WIRE

Model	Power supply wiring		Remote controller wiring Transmission wiring	
	Field fuses	Wire	Size	Wire
FXMQ20PBV36	16A	H05VV-U3G	Size must comply with local codes.	0.75-1.25 mm <sup>2</sup>
FXMQ25PBV36				
FXMQ32PBV36				
FXMQ40PBV36				
FXMQ50PBV36				
FXMQ63PBV36				
FXMQ80PBV36				
FXMQ100PBV36				
FXMQ125PBV36				
FXMQ140PBV36				

Allowable length of transmission wirings and remote controller wiring are as follows.

- (1) Outdoor unit – Indoor unit:  
Max. 1000 m (Total wiring length: 2000 m)
- (2) Indoor unit – Remote controller: Max. 500 m

NOTE

1. Shows only in case of protected pipes. Use H07RN-F in case of no protection.
2. Vinyl cord with sheath or cable (Insulated thickness : 1mm or more)

## 10. WIRING EXAMPLE AND HOW TO SET THE REMOTE CONTROLLER

### 10-1 HOW TO CONNECT WIRINGS

(Remove the control box lid and wire as shown in the figure below.)

(Remove the el. compo. box lid as shown below and connect each wire.)

- (1) Remove the el. compo. box lid.

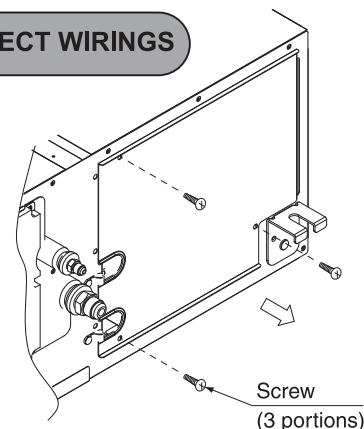

(2) Lay the wires in the el. compo. box through the wire inlet on the side of the el. compo. box.

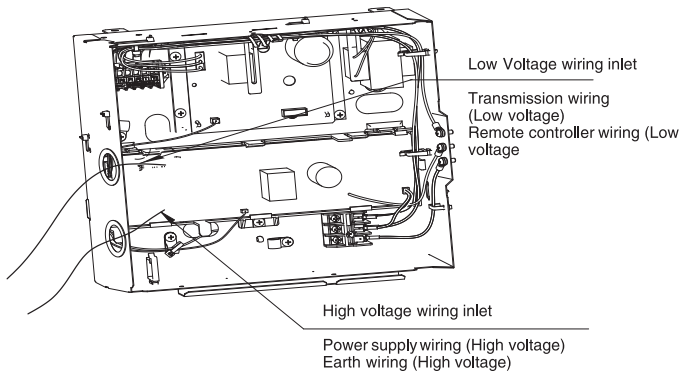

**CAUTION**

- Do not lay the remote controller wiring or transmission wiring along with the power supply wiring or other electric wiring in the same route. Separate the remote controller wiring and transmission wiring at least 50 mm from the power supply wiring or other electric wiring, or otherwise malfunctions or failures may be caused by external electric noise that may interfere with the remote controller wiring and transmission wiring.
- For the installation and wiring of the remote controller, refer to the remote controller installation manual provided with the remote controller.
- For power supply wiring, refer to the wiring diagram as well.
- Be sure to connect the remote controller wiring and transmission wiring correctly to the right terminal block.

(3) Follow the instructions below, and lay the wires in the el. compo. box.

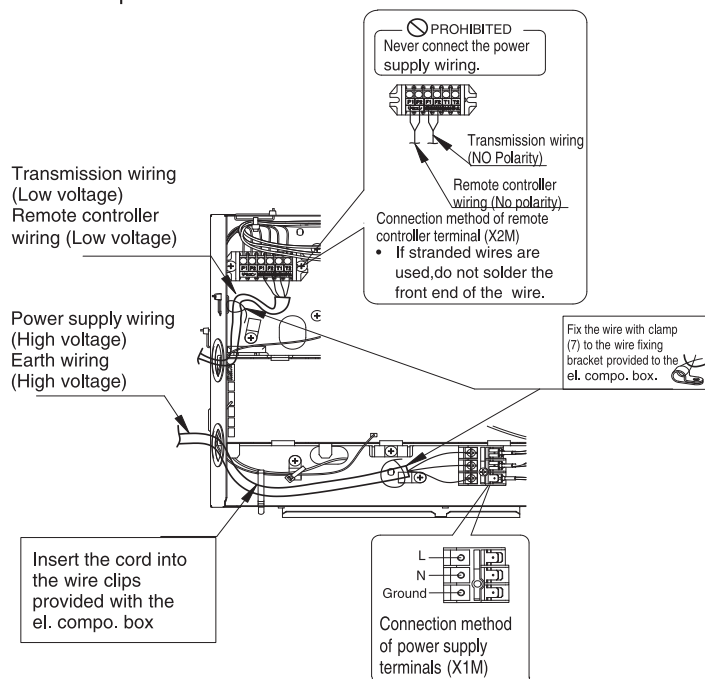

**WARNING**

Trim and lay the wiring neatly and attach the el. compo. box lid securely. An electric shock or fire may result if the el. compo. box lid catches any wiring or the wires push up the lid.

(4) Put the el. compo. box lid, and wrap the wire sealing material (Small (9)) around the wires in order to block the wire through holes.

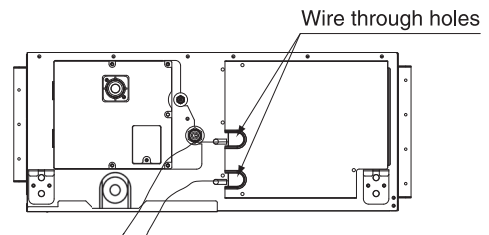

**CAUTION**

- After all the wiring connections are done, fill in any gaps in the through holes with putty or insulation (procured locally) to prevent small animals and insects from entering the unit from outside. (If any do get in, they could cause short circuits in the el. compo. box.)

(5) Mount the provided wire fixing bracket (10) with the wire fixing screw (11). Fix each wire with the provided clamp (7).

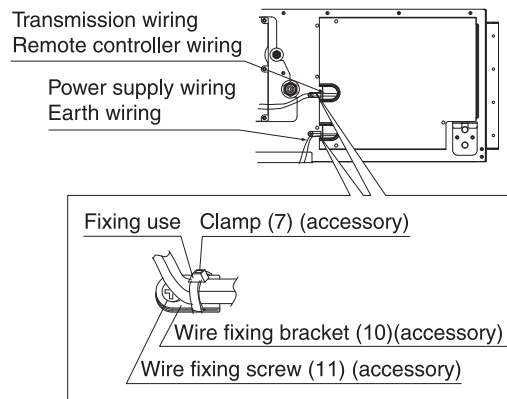

[Precautions for Power Supply Wiring]

- Connect round crimp-style terminals provided with insulation sleeves to the terminal block for power supply.

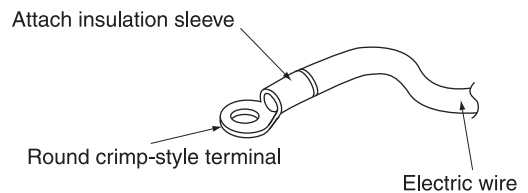

Be sure to follow the instructions provided below if the specified terminals cannot be used. Otherwise, abnormal heat may be generated as a result of the loosening of the wires.

Connect the wires evenly.

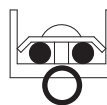

Do not connect a wire to the single side only.

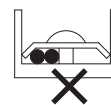

Do not connect wires different from each other in diameter.

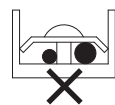

- If stranded wires are used, do not solder the front end of the wires.
- Connect proper wires securely and fix the wires so that external force will not be imposed on the terminals.
- Use an appropriate screwdriver to tighten the terminal screws. The screw heads may be damaged if the screwdriver is too small and the terminal screws will not be tightened properly.
- Do not tighten the terminal screws excessively, or otherwise the screw heads may be damaged.
- Refer to the table below for the required tightening torque values of the terminal screws.

	Tightening torque (N·m)
Terminal block for remote controller and transmission wires	0.80 - 0.96
Terminal block for power supply	1.18 - 1.44

10-2 WIRING EXAMPLE

**WARNING**

Install an earth leakage breaker.  
The installation of an earth leakage breaker is imperative for the prevention of electric shocks and fire accidents.

**OVER VOLTAGE KIT WIRING:-** **RECOMMENDATION TO USE**  
• Over voltage kit wiring guide (BRV2AK)

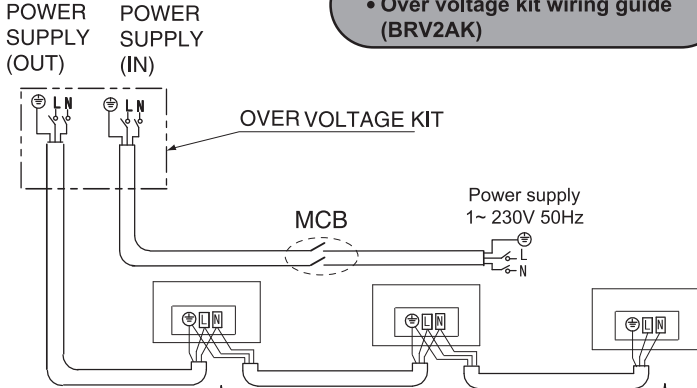

**MAX CURRENT LIMIT**

MODEL NO	BRV2AK
MAX Amps	35 Amps

**FUNCTION:-** IT IS USED TO PROTECT FROM OVER VOLTAGE AND UNDER VOLTAGE CONDITION.

**For Detailed Installation:-** See BRV2AK installation Manual

**No. 1 system**

When using 1 remote controller for 1 indoor unit

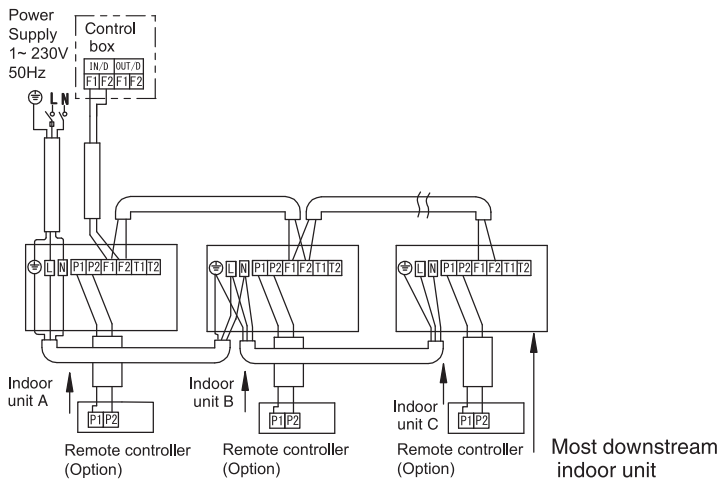

**No. 2 system**

For group controller use with 2 remote controllers

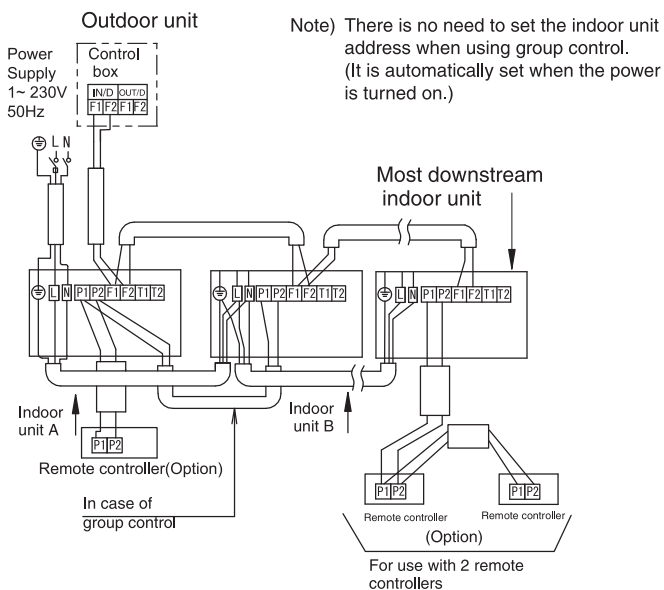

**No. 3 system :-** When including BS unit

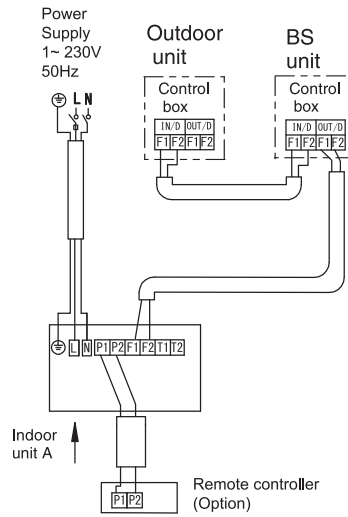

**PRECAUTIONS**

1. If no earth leakage breaker is required, install a breaker or load switch with a fuse for the wiring. If an earth leakage breaker is required, make sure that the earth leakage breaker is designed to protect the air conditioner from ground faults, overloads, and short circuiting.
2. The remote controller wiring (P1 and P2) and transmission wiring (F1 and F2) have no polarity.

**10-3 CONTROL BY 2 REMOTE CONTROLLERS (Controlling 1 unit by 2 remote controllers)**

- Set one of the remote controllers to main and the other to sub in the case of remote control with two remote controllers.

Switching Main/Sub

- (1) Insert a ⊖ screwdriver into the clearance between the grooves of the lower casing and the upper casing to remove the upper casing. (2 grooves) (The remote controller PCB is attached to the upper casing.)

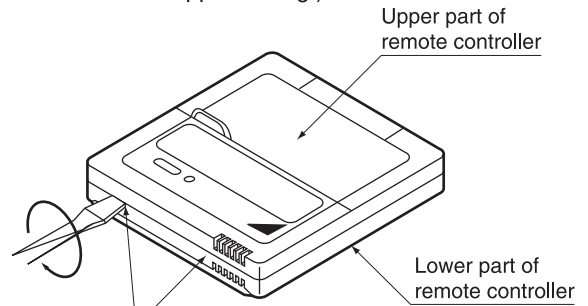

Insert the screwdriver here and gently work off the upper part of remote controller.

- (2) Set the main/sub switch on one of the remote controller PCBs to sub. (Keep the switch of the other remote controller PCB set to main.)

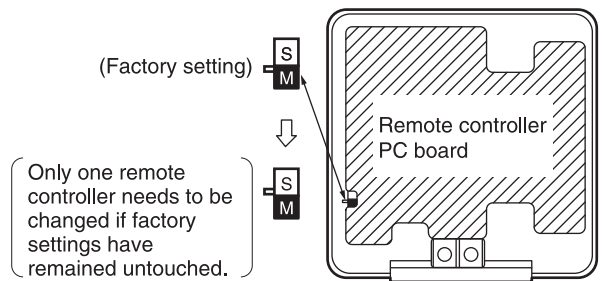

### 10-4 COMPUTRISED CONTROL (FORCED OFF AND ON/OFF OPERATION).

- (1) Wire specifications and how to perform wiring
  - Connect the input from outside to terminals T1 and T2 of the terminal block for remote controller.

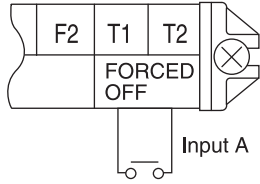

Wire specification	Sheathed vinyl cord or cable (2 wire)
Gauge	0.75 - 1.25 mm <sup>2</sup>
Length	Max. 100 m
External terminal	Contact that can ensure the minimum applicable load of 15 V DC, 1 mA.

- (2) Actuation
  - The following table explains FORCED OFF and ON/OFF OPERATIONS in response to Input A.

FORCED OFF	ON/OFF OPERATION
Input "ON" stops operation (impossible by remote controllers.)	Input OFF → ON turns ON unit.
Input OFF enables control by remote controller.	Input ON → OFF turns OFF unit.

- (3) How to select FORCED OFF and ON/OFF OPERATION
  - Turn the power on and then use the remote controller to select operation.

### 10-5 CENTRALIZED CONTROL

- For centralized control, it is necessary to designate the group No. For details, refer to the manual of each optional controllers for centralized control.

## 11. FIELD SETTING

#### NOTE

- Before the test operation of the outdoor unit as explained in 12. TEST OPERATION, be sure to make the following field settings as explained in 11. FIELD SETTING.

Make sure the el. compo. box lids are closed on the indoor and outdoor units.

Field setting must be made from the remote controller in accordance with the installation condition.

- Setting can be made by changing the "MODE NO.", "FIRST CODE NO.", and "SECOND CODE NO."
- For setting and operation, refer to the "FIELD SETTING" in the installation manual of the remote controller.

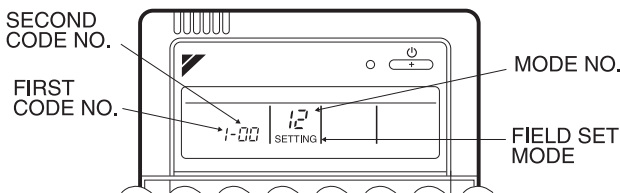

- Set the remote controller to the "FIELD SET MODE". For details, refer to the "HOW TO SET IN THE FIELD", in the remote controller manual.
- When in the "FIELD SET MODE", select "MODE NO. 12", then set the "FIRST CODE NO." to "1". Then set "SECOND CODE NO." to "01" for FORCED OFF and "02" for ON/OFF OPERATION. (FORCED OFF at factory set)

#### With Wireless Remote Controller Used

Set the wireless remote controller address before using the wireless remote controller.

For the setting method of the address, refer to the operation manual provided with the wireless remote controller.

#### NOTE

- A "MODE NO." is set on a group basis. To make a mode setting on a room unit basis or check the setting made, however, set the corresponding mode number in the parentheses.

1. Settings for Optional Accessories
  - In the case of connecting optional accessories, refer to the operation manuals provided with the optional accessories and make necessary settings.

#### 2. External Static Pressure Settings

Make settings in either method (a) or method (b) as explained below. (FXMQ14PBV36 cannot be selected method (a). Please select method (b).)

(a) Use the airflow auto adjustment function to make settings. Airflow auto adjustment: The volume of blow off air is automatically adjusted to the rated quantity.

(1) Check that power supply wiring to the air conditioner is completed along with duct installation. If a closing damper is installed in the air-conditioning system, make sure that the closing damper is opened. Furthermore, check that the air filter as a field supply is attached to the air passage on the suction side.

(2) If there are a number of air outlets and inlets, adjust the throttles so that the airflow rate of each air outlet and inlet will coincide with the designed airflow rate. At that time, operate the air conditioner in "fan operation mode". To change the airflow rate, press and set the airflow adjustment button of the remote controller to HH, H, or L.

(3) Make settings for airflow automatic adjustment. After setting the air conditioner to "fan operation mode", stop the air conditioner, go to "FIELD SET MODE", select "MODE NO. 21" (11 in the case of group settings), set the setting "FIRST CODE NO." to 7, and set the setting "SECOND CODE NO." to 03.

Return to normal mode after these settings, and press the ON/OFF OPERATION button. Then the operation lamp will be lit and the air conditioner will go into fan operation for airflow automatic adjustment. Do not adjust the throttles of the air outlets or inlets during automatic adjustment of the air conditioner. After the air conditioner runs approximately one to eight minutes, the air conditioner will finish airflow adjustment automatically, the operation lamp will be turned OFF, and the air conditioner will come to a stop.

Table 4

MODE NO.	FIRST CODE NO.	Setting contents
11 (21)	7	Airflow adjustment
SECOND CODE NO.		
01	02	03
OFF	Completion of airflow adjustment	Start of airflow adjustment

- (4) After the air conditioner stops operating, check with "MODE NO. 21" on an indoor unit basis that 02 is set for the "SECOND CODE NO." in Table 4. If the air conditioner does not stop operating automatically or the "SECOND CODE NO." is not 02, repeat steps from (3). If the outdoor unit is not turned ON, U4 or UH as explained in Table 8 will be displayed. This display is not problematic, because this function is set for the indoor unit. Continue setting the function. After setting this function, be sure to turn ON the outdoor unit before the test operation of the outdoor unit. If any other error is displayed, refer to Table 8 and the operation manual provided with the outdoor unit and check the defective point.

**CAUTION**

- If there is any change after airflow adjustment in the ventilation paths (e.g., the duct and air outlet), be sure to make airflow auto adjustment again.
- Consult your Daikin representative if there is any change in the ventilation paths (e.g., the duct and air outlet) after the test operation of the outdoor unit is finished or the air conditioner is moved to another place.

(b) Select External Static Pressure with Remote Controller  
Check that 01 (OFF) is set for the "SECOND CODE NO." in "MODE NO. 21" for airflow adjustment on an indoor unit basis in Table 4. The "SECOND CODE NO." is set to 01 (OFF) at factory set. Change the "SECOND CODE NO." as shown in Table 5 according to the external static pressure of the duct to be connected.

(1) The "SECOND CODE NO." is set to 07 (an external static pressure of 100 Pa) at factory set.

\*1 The FXMQ50 · 63 · 80 · 100 · 125PBV36 cannot be set to 30 Pa.

\*2 The FXMQ40PBV36 cannot be set to 180 or 200 Pa.

\*3 The FXMQ20 · 25 · 32 cannot be set to 110-200 Pa.

\*4 The FXMQ140PBV36 cannot be set to 30 Pa and 150-200 Pa.

Table 5

External Static Pressure	Mode No.	First Code No.	Second Code No.
30Pa (*1)(*3)	13(23)	06	01
50Pa			02
60Pa			03
70Pa			04
80Pa			05
90Pa			06
100Pa			07
110Pa (*3)			08
120Pa (*3)			09
130Pa (*3)			10
140Pa (*3)			11
150Pa (*3)(*4)			12
160Pa (*3)(*4)			13
180Pa (*2)(*3)(*4)			14
200Pa (*2)(*3)(*4)	15		

**CAUTION**

Keep in mind that a shortage of airflow quantity or water leakage will result because the air conditioner will be operated outside the rated range of airflow quantity if the external static pressure is wrongly set.

3. Filter Sign Settings

- The remote controller is provided with an LCD that tells the time of air filter cleaning.
- If the air conditioner is used in places with excessive dust, change the "SECOND CODE NO." as shown in Table 6. The "SECOND CODE NO." is set to 01 (standard) at factory set.

Table 6

Dirt	Time for display	Mode No.	First Code No.	Secon Code No.
Standard	Approximately 2500 hours			01
Excessive Dust	Approximately 1250 hours	10 (20)	0	02
No Display (*)			3	

\* Select "No display" under conditions in which the cleaning display is not required, such as the time of regular maintenance.

4. Switching time of the dry operation at VRTsmart control setting.

- If you change the operation mode to "Dry" when VRTsmart control is in effect, the operation mode is change to "Cooling" after certain period of time. If you want to continue dry operation longer, please change the setting position as mentioned in the table below. (Setting position of factory setting is "0".)
- ※ If you keep dry operation longer, energy saving performance decrease.

Dry operation	Mode number	Setting switch number	Setting position number
30 min	10	10	01
60 min			02
90 min			03
Continuous (Not return to Cooling)			04

※ At the time of Group control setting, Dry operation time for the indoor units in the same group shall be the same setting value.

**12. TEST OPERATION**

Refer to the installation manual of the outdoor unit.

- The operation lamp of the remote controller will flash when any malfunction occurs. Check the malfunction code on the liquid crystal display to identify the point of troub explanation of malfunction codes and the corresponding trouble is provided "CAUTION FOR SERVICING" of the outdoor unit. If any of the items in Table 8 are displayed, there may be a problem with the wiring or power,so check the wiring again.

Table 7

Remote controller display	Contents
"A8" Lit	Error in power supply voltage to indoor unit.
"C1" Lit	Fan driver PCB of indoor unit ↔ indoor control PCB transmission error.
"C6" Lit	Improper combination of fan driver PCB of indoor unit or setting failure in control PCB type.
"U3" Lit	Test operation of outdoor unit has not been finished.

Table 8

Remote Controller Display	Contents
"  is Lit up	• There is a short circuit at the FORCED OFF terminals (T1,T2)
"U4" is lit up "UH" is lit up	• The Power on the outdoor unit is off. • The outdoor unit has not been wired for power supply. Incorrect wiring for the transmission wiring and/or FORCED OFF wiring.
No display	•The Power on the indoor unit is off. •The indoor unit has not been wired for power supply. •Incorrect wiring for the remote controller wiring,the transmission wiring and/or the FORCED OFF wiring.

**CAUTION**

If interior finish work is continuing on completion of the test operation of the air conditioner, explain the customer not to operate the air conditioner until the interior finish work is completed for the protection of the air conditioner. Otherwise, substances that will be generated from interior finish work materials, such as paint and adhesive agents, may contaminate the air conditioner.



**SYSTEM Inverter Air Conditioners**

MODELS:- Ceiling-mounted Duct type

- |                    |                     |                     |
|--------------------|---------------------|---------------------|
| <b>FXMQ20PBV36</b> | <b>FXMQ50PBV36</b>  | <b>FXMQ125PBV36</b> |
| <b>FXMQ25PBV36</b> | <b>FXMQ63PBV36</b>  | <b>FXMQ140PBV36</b> |
| <b>FXMQ32PBV36</b> | <b>FXMQ80PBV36</b>  |                     |
| <b>FXMQ40PBV36</b> | <b>FXMQ100PBV36</b> |                     |

**FOR STANDARD MODEL**

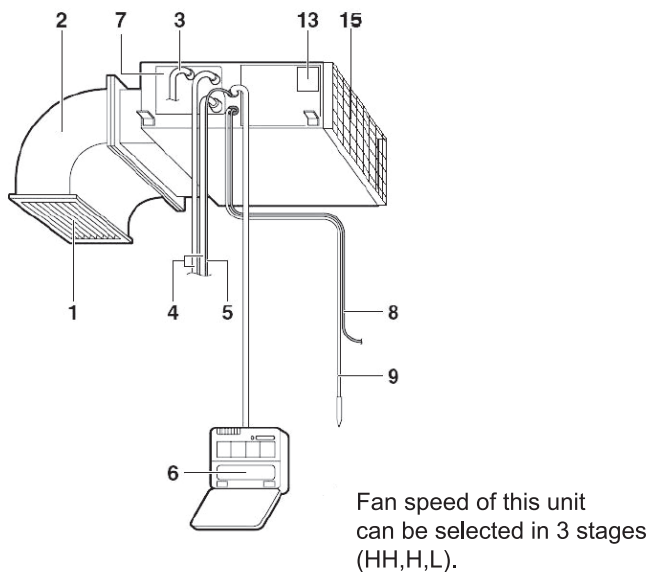

Fig.1

**FOR OPTIONAL USE OF  
1.HIGH EFFICIENCY CHAMBER KIT  
2.LONG LIFE REPLACEMENT FILTER  
CHAMBER KIT.**

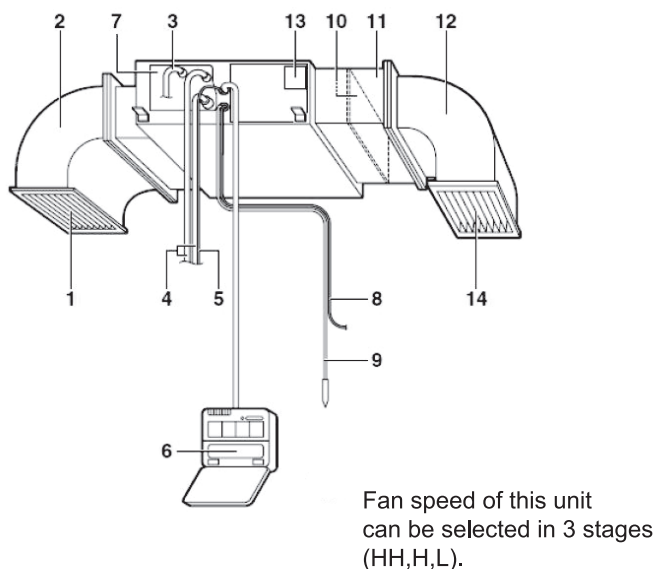

Fig.2

**Important information regarding the refrigerant used**

This product contains fluorinated greenhouse gases covered by the Kyoto Protocol.

Refrigerant type	R410A
GWP <sup>(1)</sup> value	1975

<sup>(1)</sup> GWP = global warming potential

Periodical inspections for refrigerant leaks may be required depending on European or local legislation. Please contact your local dealer for more information.

**SAFETY PRECAUTIONS**

To gain full advantage of the air conditioner's functions and to avoid malfunction due to mishandling, we recommend that you read this instruction manual carefully before use.

- This air conditioner is classified under "appliances not accessible to the general public". (The unit is to be installed at a minimum height of 2.5 m.)
- The precautions described herein are classified as **WARNING** and **CAUTION**. They both contain important information regarding safety. Be sure to observe all precautions without fail.

**⚠ WARNING** ..... Failure to follow these instructions properly may result in personal injury or loss of life.

**⚠ CAUTION** ..... Failure to observe these instructions properly may result in property damage or personal injury, which may be serious depending on the circumstances.

- After reading, keep this manual in a convenient place so that you can refer to it whenever necessary. If the equipment is transferred to a new user, be sure also to hand over the manual.

**⚠ WARNING**

- Consult your local dealer about installation work. Doing the work yourself may result in water leakage, electric shocks or fire hazards.
- Consult your local dealer regarding modification, repair and maintenance of the air conditioner. Improper workmanship may result in water leakage, electric shocks or fire hazards.
- Be sure to use fuses with the correct ampere reading. Do not use improper fuses, copper or other wiring as a substitute, as this may result in electric shocks, a fire, injury or damage to the air conditioner.

## MAINTENANCE

- **To avoid electric shocks, do not operate with wet hands.**
- **Beware of fire in case of refrigerant leakage.**  
If the air conditioner is not operating correctly, i.e. not generating cool or warm air, refrigerant leakage could be the cause. Consult your dealer for assistance.  
The refrigerant within the air conditioner is safe and normally does not leak. However, in the event of a leakage, contact with a naked burner, heater or cooker may result in generation of noxious gas.  
Do not longer use the air conditioner until a qualified service person confirms that the leakage has been repaired.
- **Consult your local dealer regarding relocation and reinstallation of the air conditioner.**  
Improper installation work may result in leakage, electric shocks or fire hazards.

 CAUTION

- **Do not place objects in direct proximity of the outdoor unit and do not let leaves and other debris accumulate around the unit.**  
Leaves are a hotbed for small animals which can enter the unit. Once in the unit, such animals can cause malfunctions, smoke or fire when making contact with electrical parts.
- **Do not allow a child to mount on the outdoor unit or avoid placing any object on it.**  
Falling or tumbling may result in injury.
- **The appliance is not intended for use by unattended young children or infirm persons.**  
Impairment of bodily functions and harm to health may occur.
- **Children should be supervised to ensure that they do not play with the unit or its remote controller.**  
Accidental operation by a child may occur in impairment of bodily functions and harm health.
- **Do not let children play on or around the outdoor unit.**  
If they touch the unit carelessly, injury may be caused.
- **Do not block air inlets nor outlets.**  
Impaired air flow may occur in insufficient performance or trouble.

## NAME OF PARTS

Refer to figure 1 & 2 on page [14]

1. Air outlet (Field supply)
2. Exhaust duct (Field supply)
3. Drain pipe
4. Connection piping
5. Transmission wiring
6. Remote controller (Sold separately)
7. Drain discharge device (built-in)  
Discharges indoor moisture removed during cooling operation.
8. Power line
9. Grounding wire  
This wire releases electricity from the indoor unit to the ground in order to prevent electric shock or fire.
10. Air filter (inside filter chamber) (Sold separately)
11. Suction filter chamber (Sold separately)
12. Suction duct (Field supply)
13. Machine nameplate  
The nameplate is imprinted with the machine name and specifications.
14. Suction grille (Field supply)
15. Air Filter

 WARNING

- **Only a qualified person is allowed to perform maintenance except daily maintenance.**
- **Before touching any of connection wirings, be sure to turn off all power supply switches.**
- **Do not use flammable materials (e.g., hairspray or insecticide) near the product.**  
**Do not clean the product with organic solvents such as paint thinner.**  
The use of organic solvents may cause crack damage to the product, electric shocks, or fire.
- **Contact professional personnel about attachment of accessories and be sure to use only accessories specified by the manufacturer.**  
If a defect results from your own workmanship, it may result in water leaks, electric shock or fire.
- **Consult your dealer regarding cleaning the inside of the air conditioner.**  
Improper cleaning may cause breakage of plastic parts, water leakage and other damage as well as electric shocks.

 CAUTION

- **Before cleaning, be sure to stop unit operation, turn the breaker off or remove the power cord.** Otherwise, an electric shock and injury may occur.
- **Do not wash the air conditioner with water, as this may result in electric shocks or fire.**
- **Watch your steps at the time of air filter cleaning or inspection.**  
Highplace work is required, to which utmost attention must be paid.  
If the scaffold is unstable, you may fall or topple down, thus causing injury.
- **Start or stop the air conditioner with the remote controller. Never use the power circuit breaker for this purpose.**  
Otherwise, it may cause a fire or water leakage.  
Furthermore, if an automatic restart control is provided against power failure and the power is recovered, the fan will rotate suddenly and may cause injury.

## How to clean the air filter

(The air filter is an optional accessory.)

1. **Clean the air filter when the display shows “” (TIME TO CLEAN AIR FILTER).**
  - This message is displayed once the unit has operated for a certain amount of time.
  - Always clean the air filter at the beginning of the heating or cooling season.  
(Dust and dirt in the air filter reduce airflow, lowering the unit's capacity.)
  - Clean the air filter more frequently when using the unit in a dirty environment.

NOTES 

- Do not remove the air filter for other than cleaning purposes.  
Doing so may cause damage to the unit.
- Do not install any object other than a proper air filter in the suction inlet (for example, a paper towel). Doing so may result in degraded performance and cause freezing or water leakage.

**2. Press the FILTER SIGN RESET BUTTON of the remote controller after the air filter is cleaned and attached.**

The “” (TIME TO CLEAN AIR FILTER) display turns OFF.

Refer to the operation manual provided with the outdoor unit for the positions of the “” (TIME TO CLEAN AIR FILTER) display and FILTER SIGN RESET BUTTON.

**HOW TO CLEAN AIR OUTLET AND OUTSIDE PANELS (Field supply)**

1. Clean with soft cloth.
2. When it is difficult to remove stains, use water or neutral detergent.

**NOTES** 

- Do not use gasoline, benzene, thinner, polishing powder, liquid insecticide. It may cause discoloring or warping.
- Do not let the indoor unit get wet. It may cause an electric shock or a fire.
- Do not use hot water of 50°C or higher, as doing so may result in discoloration or deformation.

**Maintenance and Inspection**

- For cleaning, consult with your Daikin dealer. (Before each season when cooling or heating is required, clean the air conditioner.)
- If the area around the indoor unit is very dusty, use a dust-proof cover (local procurement).



**<Cleaning the inside of the indoor unit>**

- It is necessary to clean the inside of the indoor unit periodically.  
Since the cleaning requires special technologies, request a Daikin dealer to clean them.

**Daily maintenance:**

**<Cleaning the air filter>**

**Explanation**

- Removing the air filter except when cleaning the air conditioner may result in accidents.
- When the  mark is displayed on the remote controller, please clean the filter.
- When the operating time exceeds the designated time, this mark will be displayed.
- If using the air conditioner under very dusty environment, increase the frequency of air filter cleaning.
- When you want to change the setting time until the  mark is displayed, consult with your dealer. (The default factory setting is 2500 hours.)
- There are the following time, display pattern 1250, 2500, 5000, 10000.

**1. Method for servicing of Filter**

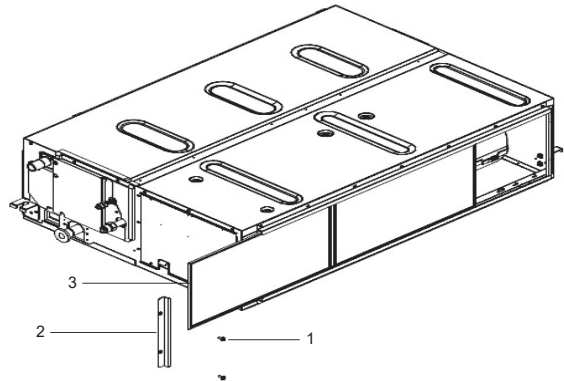

1. Remove the 2 no. of Screw
2. Remove Flange
3. Slide Filter for service/Cleaning.

**2. Clean it.**

**CAUTION**

- Do not wash the air conditioner with hot water of more than 50°C. Doing so may result in discoloration or deformation.
- Never dry the filter by direct firing. Doing so may result in burning.
- For cleaning local procurements, consult with your dealer.

(1) Use a vacuum cleaner (A) or wash the air filter (B) to remove dust and trash.

(A) Remove dust and trash using a vacuum cleaner.



(B) Wash it with water.

When the air filter is very dirty, use a soft brush and neutral detergent.



Dewater and dry in the shade.



**3. Attach the air filter.**

**4. Push the “filter sign reset” button on the remote controller.**

The display “” vanishes.

**DAIKIN AIRCONDITIONING INDIA PVT. LTD.**

Head office:-

12th Floor, Building No. 9, Tower A, DLF Cyber City,  
DLF Phase-III, Gurgaon-122 002, Haryana, (India)

DAIKIN Service Call Center

Toll free 1800-102-9300 (All Mobile/Landline)

1800-22-9300 (MTNL/BSNL)

**3P714597-4C**