SPLIT SYSTEM**Air Conditioner**

MODELS**Ceiling mounted cassette type (Sensing and Non Sensing flow model)**

		<i>Page No.</i>
INDOOR	OUTDOOR	Installation Manual.....01-53
		Operation Manual.....54-65
FCFQ24CV1	RZCFQ24CV1	E-Waste (Guidelines).....66
		<i>Split Type Air Conditioner</i>

English

CAREFULLY READ THESE INSTRUCTIONS BEFORE INSTALLATION.
KEEP THIS MANUAL IN A HANDY PLACE FOR FUTURE REFERENCE.

CONTENTS

1. SAFETY PRECAUTIONS 1

2. BEFORE INSTALLATION..... 3

3. SELECTING INSTALLATION SITE..... 5

4. PREPARATION BEFORE INSTALLATION..... 7

5. INDOOR UNIT INSTALLATION..... 9

6. REFRIGERANT PIPING WORK..... 11

7. DRAIN PIPING WORK..... 13

8. ELECTRIC WIRING WORK..... 17

9. WIRING EXAMPLE..... 20

10. INSTALLATION OF THE DECORATION PANEL..... 22

11. FIELD SETTING..... 23

12. TEST OPERATION..... 26

13. TECHNICAL DATA..... 30

14. UNPACKING & PACKING OF THE INDOOR..... 31

1. SAFETY PRECAUTIONS

	Read the precautions in this manual carefully before operating the unit.		This appliance is filled with R32.
--	--	--	------------------------------------

Please read these "SAFETY PRECAUTIONS" carefully before installing air conditioning equipment and be sure to install it correctly. After completing the installation, make sure that the unit operates properly during the start-up operation. After completing installation, conduct a trial operation to check for faults and explain to the customer how to operate the air conditioner and take care of it with the aid of the operation manual. Ask the customer to store the installation manual along with the operation manual for future reference.

This air conditioner comes under the term "appliances not accessible to the general public".

Please instruct the customer on how to operate the unit and keep it maintained.

Also, inform customers that they should store this installation manual along with the operation manual for future reference.

Meaning of WARNING and CAUTION notices.

WARNING Failure to follow these instructions properly may result in personal injury or loss of life.

CAUTION Failure to observe these instructions properly may result in property damage or personal injury, which may be serious depending on the circumstances.

WARNING

- Ask your dealer or qualified personnel to carry out installation work.
Do not attempt to install the air conditioner yourself. Improper installation may result in water leakage, electric shocks or fire.
- Install the air conditioner in accordance with the instructions in this installation manual.
Improper installation may result in water leakage, electric shocks or fire.
- Be sure to use only the specified accessories and parts for installation work.
Failure to use the specified parts may result in the unit falling, water leakage, electric shocks or fire.
- Install the air conditioner on a foundation strong enough to withstand the weight of the unit.
A foundation of insufficient strength may result in the equipment falling and causing injury.
- Carry out the specified installation work after taking into account strong winds, typhoons or earthquakes.
Failure to do so during installation work may result in the unit falling and causing accidents.
- Make sure that a separate power supply circuit is provided for this unit and that all electrical work is carried out by qualified personnel according to local laws and regulations and this installation manual.
An insufficient power supply capacity or improper electrical construction may lead to electric shocks or fire.
- Make sure that all wiring is secured, the specified wires are used, and that there is no strain on the terminal connections or wires.
Improper connections or securing of wires may result in abnormal heat build-up or fire.
- When wiring the power supply and connecting the wiring between the indoor and outdoor units, position the wires so that the control box lid can be securely fastened.
Improper positioning of the control box lid may result in electric shocks, fire or overheating terminals.

- If refrigerant gas leaks during installation, ventilate the area immediately. Toxic gas may be produced if the refrigerant comes into contact with fire.
- After completing installation, check for refrigerant gas leakage. Toxic gas may be produced if the refrigerant gas leaks into the room and comes into contact with a source of fire, such as a fan heater, stove or cooker.
- When installing or relocating the air conditioner, be sure to bleed the refrigerant circuit to ensure, it is free of air, and use only the specified refrigerant (R32).
The presence of air or other foreign matter in the refrigerant circuit causes abnormal pressure rise, which may result in equipment damage and even injury.
- Be sure to switch off the unit before touching any electrical parts.
- Do not directly touch refrigerant that has leaked from refrigerant pipes or other areas, as there is a danger of frostbite.
- Be sure to earth the air conditioner.
Do not earth the unit to a utility pipe, lightning conductor or telephone earth lead.
Imperfect earthing may result in electric shocks or fire.
A high surge current from lightning or other sources may cause damage to the air conditioner.
- Be sure to install an earth leakage breaker.
Failure to install an earth leakage breaker may result in electric shocks or fire.
- Consult your local dealer regarding what to do in case of refrigerant leakage. When the air conditioner is to be installed in a small room, it is necessary to take proper measures so that the amount of any leaked refrigerant does not exceed the concentration limit in the event of a leakage. Otherwise, this may lead to an accident due to oxygen depletion.
- Do not allow children to climb on the outdoor unit and avoid placing objects on the unit.
Injury may result if the unit becomes loose and falls.
- The appliance must be stored in a room without continuously operating ignition sources (for example : open flames, an operating gas appliance or an operating electric heater).
- Do not pierce or burn.
- Be aware that refrigerant may not contain an odour.
- Floor area required for installation of the equipment, refer to the installation manual of the outdoor unit.
- Comply with national gas regulations.
- When flared joints are reused indoors, the flare part shall be re-fabricated.

CAUTION

- While following the instructions in this installation manual, install drain piping to ensure proper drainage and insulate piping to prevent condensation.
Improper drain piping may result in indoor water leakage and property damage.
- Install the indoor and outdoor units, power cord and connecting wires at least 1 meter away from televisions or radios to prevent picture interference and noise.
(Depending on the incoming signal strength, a distance of 1 meter may not be sufficient to eliminate noise.)
- Remote controller (wireless kit) transmitting distance can be shorter than expected in rooms with electronic fluorescent lamps (inverter or rapid start types). Install the indoor unit as far away from fluorescent lamps as possible.
- In a domestic environment this product may cause radio interference in which case the user may be required to take adequate measures.
- Make sure to provide for adequate measures in order to prevent that the outdoor unit be used as a shelter by small animals. Small animals making contact with electrical parts can cause malfunctions, smoke or fire. Please instruct the customer to keep the area around the unit clean.
- Install in a machine room that is free of moisture. The unit is designed for indoor use.
- Disposal requirements
Dismantling of the unit, treatment of the refrigerant, of oil and of other parts must be done in accordance with relevant local and national legislation.
- The refrigerant R32 requires that strict precautions be observed for keeping the system clean, dry and tightly sealed.
 - A. Clean and dry
Strict measures must be taken to keep impurities (including SUNISO oil and other mineral oils as well as moisture) out of the system.
 - B. Tightly sealed
R32 contains no chlorine, does not destroy the ozone layer and so does not reduce the earth's protection against harmful ultraviolet radiation. R32 will contribute only slightly to the greenhouse effect if released into the atmosphere.
- Do not install the air conditioner in the following locations:
 1. Where there is a high concentration of mineral oil spray or vapour (e.g. a kitchen).
Plastic parts will deteriorate, parts may fall off and water leakage could result.
 2. Where corrosive gas, such as sulphurous acid gas, is produced.
Corroding of copper pipes or soldered parts may result in refrigerant leakage.
 3. Near machinery emitting electromagnetic radiation.
Electromagnetic radiation may disturb the operation of the control system and result in a malfunction of the unit.
 4. Where flammable gas may leak, where there is carbon fibre or ignitable dust suspensions in the air, or where volatile flammables such as paint thinner or gasoline are handled.
Operating the unit in such conditions may result in fire.
- The air conditioner is not intended for use in a potentially explosive atmosphere.
- Only qualified personnel can handle, fill, purge and dispose of the refrigerant.
- Important information regarding the refrigerant used.
This product contains fluorinated greenhouse gases covered by the Kyoto protocol. Do not vent gases into the atmosphere.
Refrigerant type: R32
GWP⁽¹⁾ value: 675*
⁽¹⁾GWP = global warming potential
- The refrigerant quantity is indicated on the unit name plate.
*This value is based on F gas regulation (824/2006).

2. BEFORE INSTALLATION





Do not exert pressure on the resin parts when opening the unit or when moving it after opening. Be sure to check the type of R32 refrigerant to be used before doing any work. (Using an incorrect refrigerant will prevent normal operation of the unit.)





- When opening the unit or moving it after opening, be sure to lift it by holding on to the hanger bracket without exerting any pressure on other parts, especially, drain piping, and other resin parts.
- Decide upon a line of transport.
- Leave the unit inside its packaging while moving, until reaching the installation site. Use a sling of soft material, where unpacking is unavoidable or protective plates together with a rope when lifting, to avoid damage or scratches to the unit.
- Refer to the installation manual of the outdoor unit for items not described in this manual.
- Do not dispose of any parts necessary for installation until the installation is complete.
- In order to protect the indoor unit from damage, use packing materials to protect the unit after carrying until the installation starts.
- When selecting installation site, refer to the paper pattern.
- Do not use the unit in locations with high salt content in the air such as beachfront property, locations where the voltage fluctuates such as factories, or in automobiles or marine vessels.
- Do not install accessories on the casing directly. Drilling holes in the casing may damage electrical wires and consequently cause fire.

2-1. ACCESSORIES

Check the following accessories are included with your unit.

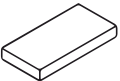
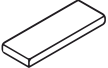
(Do not dispose of any parts necessary for installation until the installation is completed.)

Name	(1) Drain hose	(2) Metal clamp	(5) Paper pattern for installation	(7) Washer fixing plate	Insulation for fitting
Quantity	1 pc.	1 pc.	1 pc.	4 pcs.	1 each
Shape			Upper part of packing 		(8) For gas pipe  (9) For liquid pipe 

Name	Sealing pad			Installation guide	(Other)
Quantity	1 each	1 pc.	1 pc.	1 pc.	
Shape	(10) Large  (11) Medium-1  (12) Medium-2 	(13) Small 	(14) 	(15) 	<ul style="list-style-type: none"> • Installation manual • Operation manual

2-2. OPTIONAL ACCESSORIES

- The optional decoration panel and remote controller are required for this indoor unit. (Refer to Table 1, 2) (However, the remote controller is not required for the slave unit of a simultaneous operation system.)
- Check that the decoration panel is prepared. (For the installation of the decoration panel, refer to the installation manual attached to the decoration panel.)

Table 1

Unit model	Optional decoration panel
FCFQ24CV1	BYCQ125EEF9 BYCQ125EAF9
	Color : Fresh White / Black

NOTE

- If you wish to use a optional decoration panel that is not listed in “**Table 1**” on page 4, select a suitable remote controller after consulting catalogs and technical materials.
- These are two types of remote controllers: wired and wireless. Select a remote controller from **Table 2** according to customer request and install in an appropriate place.
(For the installation of the remote controller, refer to the installation manual attached to the remote controller.)

Table 2

Remote controller			
Wired type		BRC1E63	
Wireless type	Cooling only	Remote	BRC91A152
		Receiver kit	BRC7M632F-6

NOTE

- If you wish to use a remote controller that is not listed in “**Table 2**” on page 4, select a suitable remote controller after consulting catalogs and technical materials.

FOR THE FOLLOWING ITEMS, TAKE SPECIAL CARE DURING CONSTRUCTION AND CHECK AFTER INSTALLATION IS FINISHED.

1. Items to be checked after completion of work

Items to be checked	If not properly done, what is likely to occur	Check
Are the indoor unit and outdoor unit fixed firmly?	The unit may drop, vibrate or make noise.	
Is the outdoor unit fully installed?	The unit may malfunction or the components burn out.	
Is the gas leak test finished?	It may result in insufficient cooling.	
Is the unit fully insulated?	Condensate water may drip.	
Does drainage flow smoothly?	Condensate water may drip.	
Does the power supply voltage correspond to that shown on the name plate?	The unit may malfunction or the components burn out.	
Are wiring and piping correct?	The unit may malfunction or the components burn out.	
Is the unit safely grounded?	It may result in electric shock.	
Is wiring size according to specifications?	The unit may malfunction or the components burn out.	
Is something blocking the air outlet or inlet of either the indoor or outdoor units?	It may result in insufficient cooling.	
Are refrigerant piping length and additional refrigerant charge noted down?	The refrigerant charge in the system is not clear.	

2. Items to be checked at time of delivery

* Also review the “1. SAFETY PRECAUTIONS”

Items to be checked	Check
Has the field setting done (as necessary)?	
Did you attach the control box lid, the air filter, and suction grille?	
Does the cold air blow properly during the cooling operation?	
Did you explain about operations while showing the instruction manual to your customer?	
Did you hand the instruction manual over to your customer?	

Points for explanation about operations

The items with **△ WARNING** and **△ CAUTION** marks in the instruction manual are the items pertaining to possibilities for bodily injury and material damage in addition to the general usage of the product. Accordingly, it is necessary that you make a full explanation about the described contents and also ask your customers to read the instruction manual.

2-3. NOTE TO THE INSTALLER

Be sure to instruct customers how to properly operate the unit (especially cleaning filters, operating different functions, and adjusting the temperature) by having them carry out operations themselves while looking at the manual.

3. SELECTING INSTALLATION SITE

⟨Hold the unit by the 4 lifting lugs when opening the box and moving it, and do not exert pressure on to any other part piping (refrigerant, drain, etc.) or plastic parts.

If the temperature or humidity inside the ceiling might rise above 30°C or RH 80%, respectively, use the high-humidity kit (sold separately) or add extra insulation to the main unit body.

Use glass wool or polyethylene foam as insulation and make sure it is at least 10 mm thick and fits inside the ceiling opening.⟩

The direction this product blows can be selected. However, a separately sold shut-off material kit is needed in order to make the unit blow in two, three, or four (corner shut-off) directions.

(1) Select an installation location with the customer’s approval which matches the following conditions.

- Where optimum air distribution can be ensured.
- Where nothing blocks air passage.
- Where condensate can be properly drained.
- Where the ceiling is strong enough to bear the indoor unit weight.
- Where the false ceiling is not noticeably on an incline.
- Where sufficient clearance for maintenance and service can be ensured.
- Where there is no risk of flammable gas leakage.
- Where piping between indoor and outdoor units is possible within the allowable limit.

(Refer to the installation manual for the outdoor unit.)

[Space required for installation]

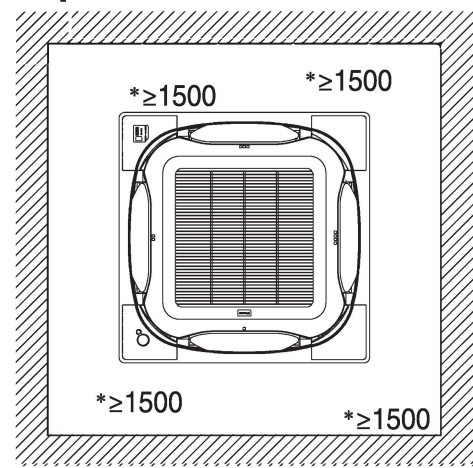
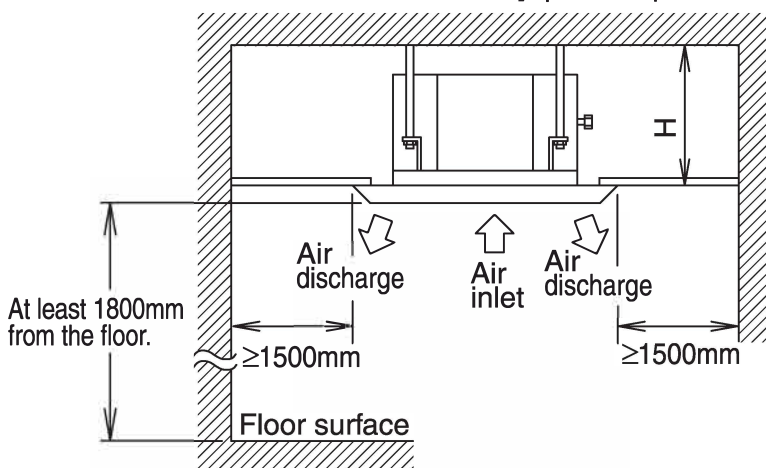

Fig. 1

(unit : mm)

Model	H(mm)
	BYCQ125EEF9 BYCQ125EAF9
FCFQ24CV1	261

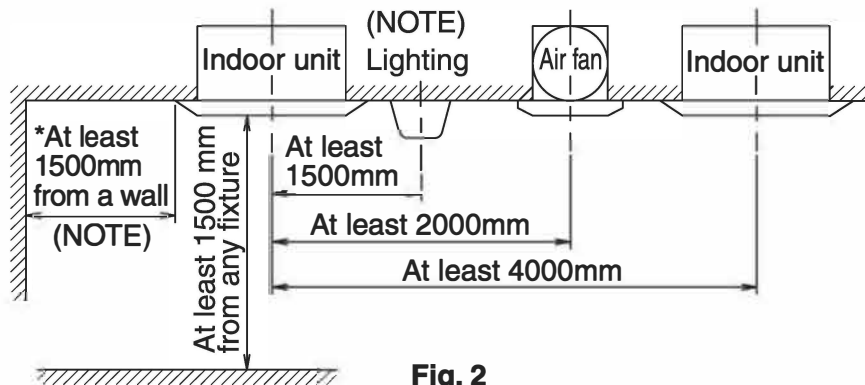

Fig. 2

NOTE

- The “*” marked space is at least 500 mm wide if the air outlet is closed. In case of also closed corner area (corner area of both left right direction for closing air outlet), it is 200 mm or more.

CAUTION

- Any vents, light fixtures, or other appliances which may disturb the airflow might cause the top side to become dirty if located too nearby, so follow Fig. 2 when installing.
 - Note)
 - This restriction applies to the exposed type lighting, but does not apply to the recessed type (which does not protrude below the ceiling line).
 - For how to set the airflow direction (including airflow block) with the horizontal blade, refer to “Individual Airflow Direction” in the operation manual attached to the remote controller.
- Keep indoor unit, outdoor unit, power supply wiring and transmission wiring at least 1 meter away from televisions and radios. This is to prevent image interference and noise in those electrical appliances. (Noise may be generated depending on the conditions under which the electric wave is generated, even if 1 meter is kept.)
- If installing the wireless kit, the distance of the signal sent from the remote controller might be shorter if there are fluorescent lights which are electrically started (such as with inverters, rapid starters, etc.) in the room. The indoor unit should be installed as far away from fluorescent lights as possible.

(2) Ceiling height

This product can be installed in ceilings up to 3.5 m high (4.2 m high for the 24, 30, and 36). If the ceiling height is 2.7 m (3.2 m for the 24, 30, and 36) or more, field settings will have to be made with the remote controller. See “11. FIELD SETTING” for details.

(3) Air direction

The air direction shown in Fig. 3 is an example.

Select the appropriate number of directions according to the shape of the room and the location of the unit. (Field settings have to be made using the remote controller and the outlet vents have to be shut off if two, three, or four (corner shut-off) directions are selected. See the shut-off materials (sold separately) installation manual for details.)

- Use suspension bolts for installation. Check if the location for the installation is strong enough to support the weight of the unit, reinforce it if necessary, and install using suspension bolts. (The spacing of the installation is shown on the “paper pattern for installation (5)”.)

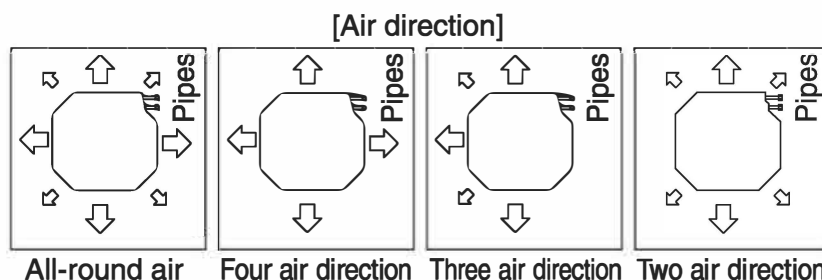
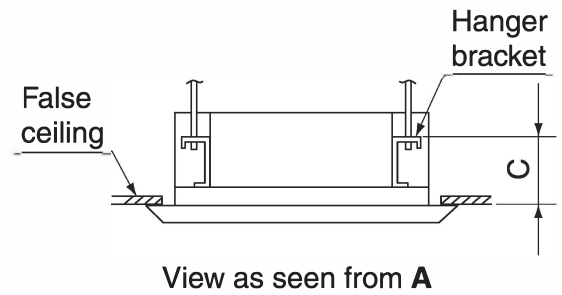
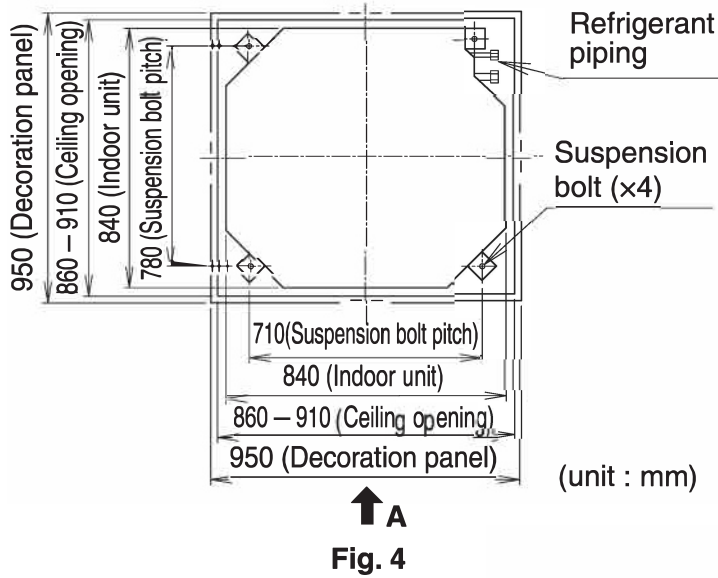

Fig. 3

4. PREPARATION BEFORE INSTALLATION

(1) Relation of ceiling opening to unit and suspension bolt position.



Decoration Panel	BYCQ125EEF9 BYCQ125EAF9
C (mm)	125~130

■ Use the installation guide (15) (delivered with the unit) for exact vertical positioning of the unit.

Apply the short side of the cut-out section in case of standard grille.

<BYCQ125EEF9>

<BYCQ125EAF9>

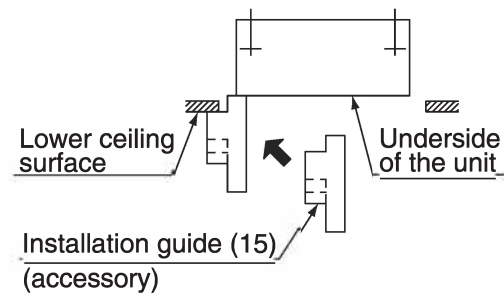

■ Installation is possible when ceiling opening dimensions is as follows.

- When installing the unit within the frame for fixing false ceiling.

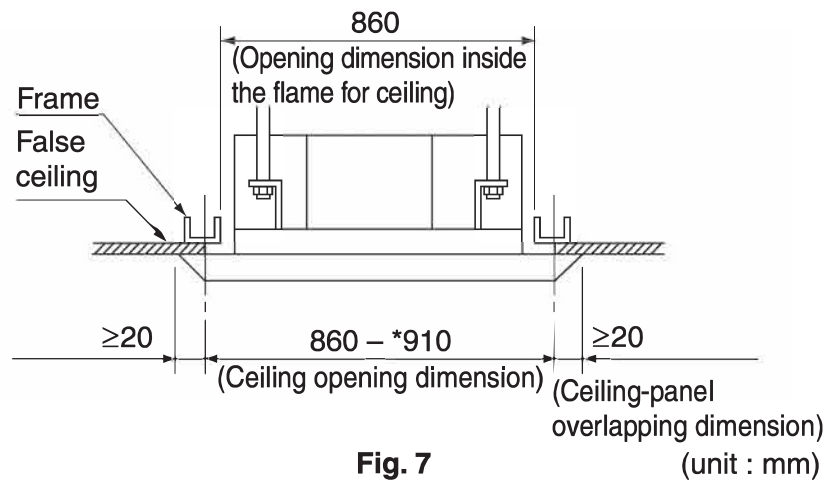
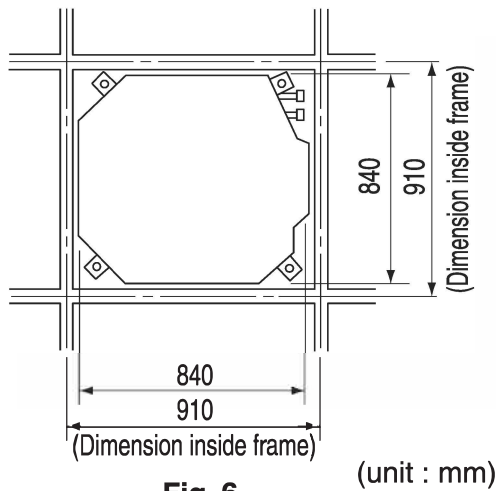

NOTE

- Installation is possible with a ceiling dimension of 910 mm (marked with *). However, to achieve a ceiling-panel overlapping dimension of 20 mm, the spacing between the ceiling and the unit should be 35 mm or less. If the spacing between ceiling and the unit is over 35 mm, attach ceiling material to ■ part or recover the ceiling.

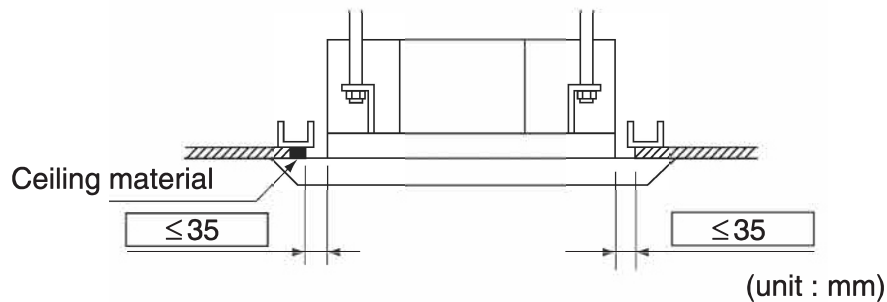

(2) Make the ceiling opening needed for installation where applicable. (For existing ceilings)

- Refer to the paper pattern for installation (5) for ceiling opening dimensions.
- Create the ceiling opening required for installation. From the side of the opening to the casing outlet, implement the refrigerant and drain piping and wiring for remote controller (unnecessary for wireless type) and indoor-outdoor unit casing outlet. Refer to “6. REFRIGERANT PIPING WORK”, “7. DRAIN PIPING WORK” and “8. ELECTRIC WIRING WORK”.
- After making an opening in the ceiling, it may be necessary to reinforce ceiling beams to keep the ceiling level and to prevent it from vibrating. Consult the builder for details.

(3) Install the suspension bolts.

- Use M8 or M10 bolts for hanging the indoor unit. Use a hole-in anchor for existing ceilings, and a sunken insert, sunken anchor or other field supplied parts for new ceilings to reinforce the ceiling to bear the weight of the unit. Adjust clearance (50 – 100 mm) from the ceiling before proceeding further.

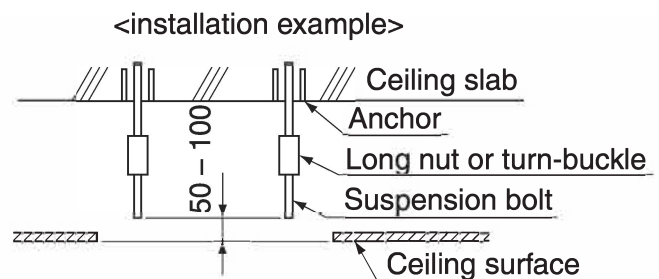

NOTE

- All the above parts are field supplied.

5. INDOOR UNIT INSTALLATION

Installing optional accessories (except for the decoration panel) before installing the indoor unit is easier. However, for existing ceilings, install fresh air inlet component kit and branch duct before installing the unit.

As for the parts to be used for installation work, be sure to use the provided accessories and specified parts designated by our company.

5.1 FOR NEW CEILINGS

(1-1) Install the indoor unit temporarily.

- Attach the hanger bracket to the suspension bolt. Be sure to fix it securely by using a nut and washer (3) from the upper and lower sides of the hanger bracket. **(Refer to Fig.10)**
The washer fixing plate (7) will prevent the washer from falling. **(Refer to Fig.11)**

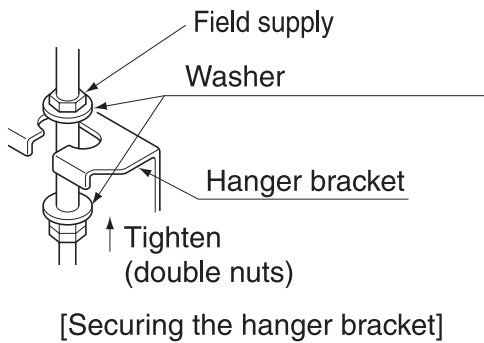

Fig. 10

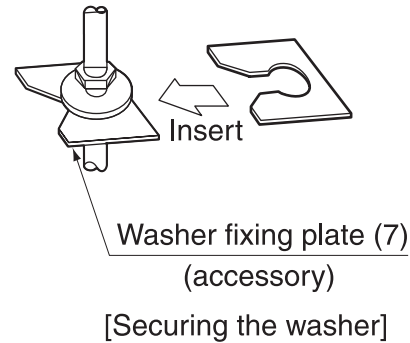

Fig. 11

(1-2) Refer to the paper pattern for installation (5) for ceiling opening dimension.

Consult the builder or carpenter for details.

- The center of the ceiling opening is indicated on the paper pattern for installation. The center of the unit is indicated on the triangular mark to the unit bottom and on the paper pattern for installation.
- Fix the paper pattern to the unit with screws (6) (×4).
- Ceiling height is shown on the side of the paper pattern for installation (5). Adjust the height of the unit according to this indication.

Please perform one of the following, as the shape of the paper pattern for installation differs according to the model.

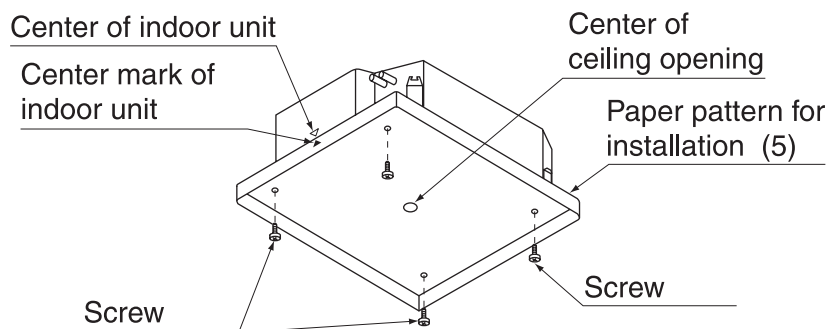

Fig. 12

[Installation of paper pattern for installation-optional]

<Ceiling work>

(1-3) Adjust the unit to the right position for installation.

(Refer to “4. PREPARATIONS BEFORE INSTALLATION-(1)”.)

- Using the installation guide (15) allows you to check the positions from the underside of the unit to the lower ceiling surface.

(1-4) Check the unit is horizontally level. (Refer to Fig.13)

- The indoor unit is equipped with a built-in drain pump and float switch. Verify that it is level by using a level or a water-filled vinyl tube.

CAUTION

- The indoor unit is equipped with a built-in drain pump and float switch. Verify that it is level by using a level or a water-filled vinyl tube.
(If the unit is tilted against condensate flow, the float switch may malfunction and cause water to drip.)

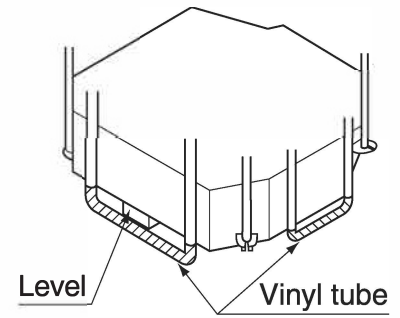

[Maintaining horizontality]

Fig. 13

(1-5) Remove the washer fixing plate (7) used for preventing the washer for hanger (3) from dropping and tighten the upper side nut.

(1-6) Remove the paper pattern for installation (5).

5.2 FOR EXISTING CEILINGS

(2-1) Install the indoor unit temporarily.

Perform step (1-1) in (1) For new ceilings.

(2-2) Adjust the height and position of the unit.

(Refer to “4. PREPARATIONS BEFORE INSTALLATION-(1)” and (1-3) in (1) For new ceilings.)

(2-3) Perform steps (1-4), (1-5) in (1) For new ceilings.

CAUTION

• **Install the indoor unit leveled.**

If the indoor unit is inclined and the drain piping side gets high, it may cause malfunction of a float switch and results in water leakage.

• **Attach nuts on the upper and lower side of hanger.**

If there is no upper nut and the lower nut is over-tightened, the hanger and the top plate will deform and cause abnormal sound.

• **Do not insert materials other than that specified into the clearance between the hanger and the washer for hanger (3).**

Unless the washers are properly attached, the hanging bolts may come off from the hanger.

WARNING

The indoor unit must be securely installed on a place that can withstand the mass.

If the strength is insufficient, the indoor unit may fall down and cause injuries.

6. REFRIGERANT PIPING WORK

- For the outdoor unit refrigerant piping, refer to the installation manual attached to the outdoor unit.
- Carry out insulation of both gas and liquid refrigerant piping securely. If not insulated, it may cause water leakage. For gas piping, use insulation material of which heat resistant temperature is not less than 120°C. For use under high humidity, strengthen the insulation material for refrigerant piping. If not strengthened, the surface of insulation material may sweat.
- Before installation work, make sure that the refrigerant is R32. (Unless the refrigerant is R32, the normal operation cannot be expected.)

⚠ WARNING

When flared joints are reused indoors, the flare part shall be re-fabricated.

⚠ CAUTION

This air conditioner is a dedicated model for new refrigerant R32. Make sure to meet the requirements shown below and carry out installation work.

- Use dedicated piping cutters and flaring tools for R32 and R410A.
 - When making a flare connection, coat the flared inner surface only with ether oil or ester oil.
 - Use only the flare nuts attached to the air conditioner. If other flare nuts are used, it may cause refrigerant leakage.
 - To prevent contamination or moisture from getting into the piping, take measures such as pinching or taping the pipings.
- Do not mix substance other than the specified refrigerant such as air into the refrigeration circuit. If the refrigerant leaks during the work, ventilate the room.

- The refrigerant is pre-charged in the outdoor unit.
- When connecting the pipings to the air conditioner, make sure to use a spanner and a torque wrench as shown in Fig. 14.
- For the dimension of flared part and the tightening torque, refer to the Table 3.

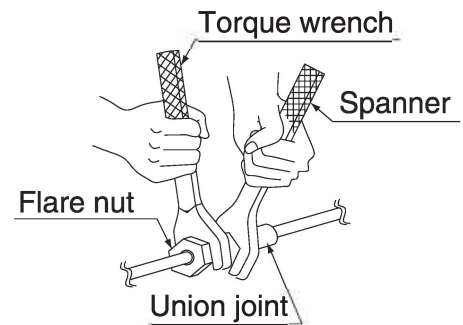

Fig. 14

- When making a flare connection, coat the flared inner surface only with ether oil or ester oil. (Refer to Fig. 15) Then, turn the flare nut 3 to 4 times with your hand and screw in the nut.

Coat the flared inner surface only with ether oil or ester oil

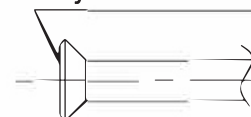

Fig. 15

Table 3

Piping size (mm)	Tightening torque (N·m)	Dimension for processing flare A (mm)	Flare shape
φ 6.4	15.7 ± 1.5	8.9 ± 0.2	
φ 9.5	36.3 ± 3.6	13.0 ± 0.2	
φ 12.7	54.9 ± 5.4	16.4 ± 0.2	
φ 15.9	68.6 ± 6.8	19.5 ± 0.2	

⚠ CAUTION

Do not have oil adhere to the screw fixing part of resin parts. If oil adheres, it may weaken the strength of screwed part. Do not tighten flare nuts too tight. If a flare nut cracks, the refrigerant may leak.

- If there is no torque wrench, use **Table 4** as a rule of thumb.
When tightening a flare nut with a spanner harder and harder, there is a point where the tightening torque suddenly increases.
From that position, tighten the nut additionally the angle shown in **Table 4**.
After the work is finished, check securely that there is no gas leak.
If the nut is not tightened as instructed, it may cause slow refrigerant leak and result in malfunction (such as does not cool or heat).

Table 4

Piping size (mm)	Tightening angle	Recommended arm length of tool used
φ 6.4	60° - 90°	approx. 150 mm
φ 9.5	60° - 90°	approx. 200 mm
φ 12.7	30° - 60°	approx. 250 mm
φ 15.9	30° - 60°	approx. 300 mm

CAUTION

Insulation of field piping must be carried out up to the connection inside the casing.
If the piping is exposed to the atmosphere, it may cause sweating, burn due to touching the piping, electric shocks or a fire due to the wiring touching the piping.

- After leak test, referring to **Fig. 16**, insulate both the gas and liquid piping connection with the attached joint insulating for fitting (8) and (9) to prevent the pipings from getting exposed.
Then, tighten the both ends of insulating material with the clamp (4).
- Wrap the sealing material (Medium-1, 2) (11) (12) around the joint insulating for fitting (8) and (9) (flare nut section), both the gas and liquid piping.
- Make sure to bring the seam of joint insulating for fitting (8) and (9) to the top.

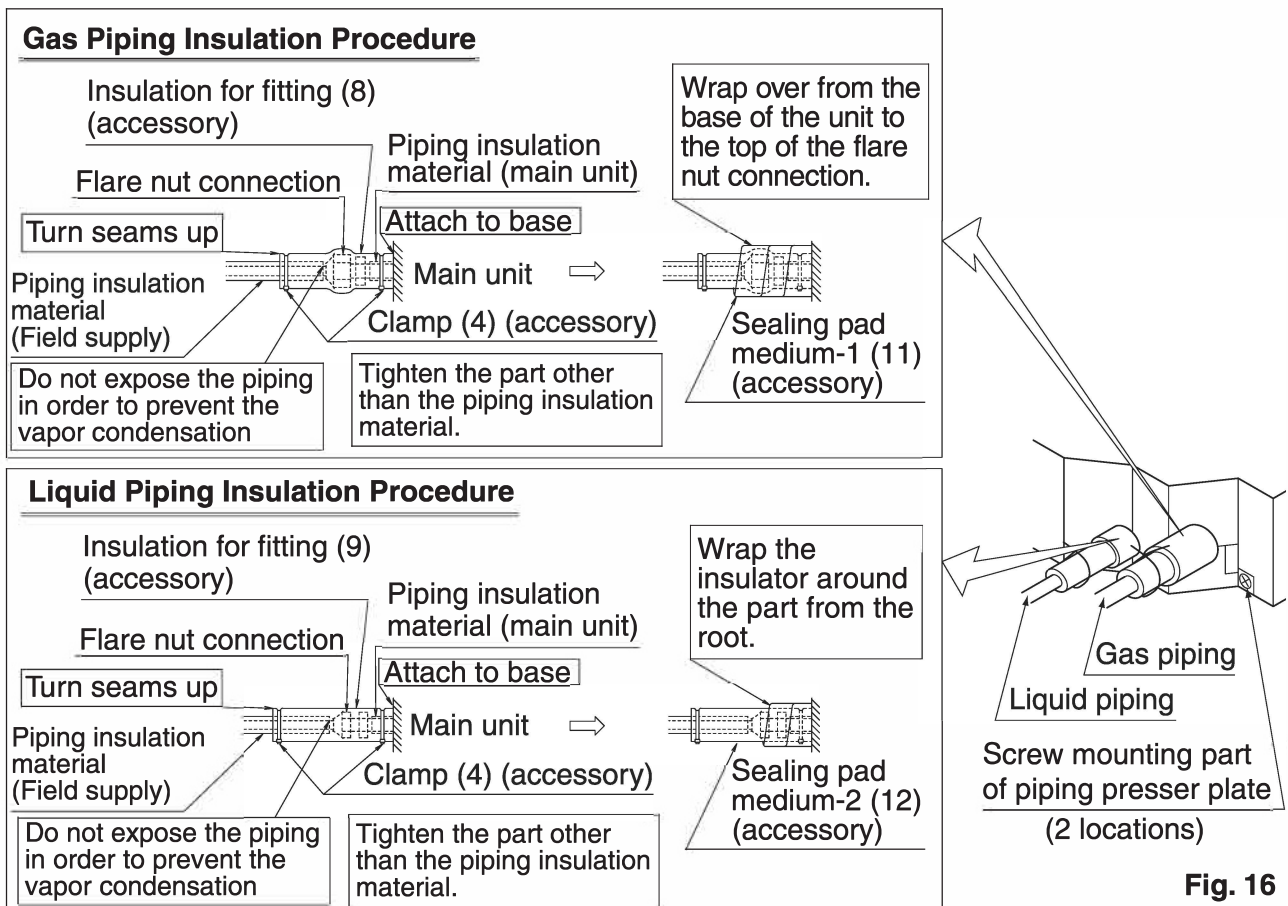

- Before brazing refrigerant piping, have nitrogen flow through the refrigerant piping and substitute air with nitrogen (NOTE 1) (Refer to Fig. 17). Then, carry out brazing (NOTE 2). After all the brazing works are finished, carry out flare connection with the indoor unit. (Refer to Fig. 16)

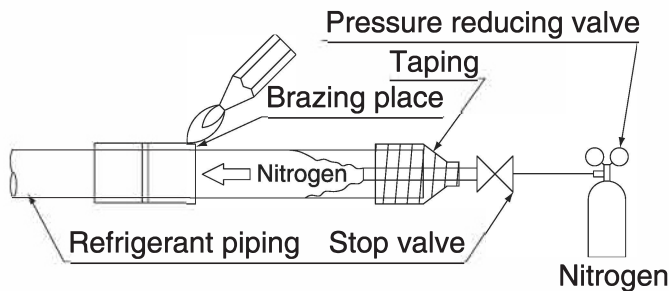

Fig. 17

NOTE

1. The proper pressure for having nitrogen flow through the piping is approximately 0.02 MPa, a pressure that makes one feel like breeze and can be obtained through a pressure reducing valve.
2. Do not use flux when brazing refrigerant piping.
Use phosphor copper brazing filler metal (BCuP-2: JISZ3264/B-Cu93P-710/795: ISO 3677) that does not require flux.
(If chlorinated flux is used, the piping will be corroded and, in addition if fluorine is contained, the refrigerant oil will be deteriorated and the refrigerant circuit will be affected badly.)
3. When carrying out leakage test of refrigerant piping and the indoor unit after the installation of indoor unit is finished, confirm the connecting outdoor unit installation manual for test pressure.
Refer to also the outdoor unit installation manual or technical document for refrigerant piping.
4. In case of refrigerant shortage due to forgetting additional refrigerant charge etc., it will result in malfunction such as does not cool or does not heat.
Refer to the outdoor unit installation manual or technical document for refrigerant piping.

CAUTION

Do not use antioxidant when brazing piping.

It may result in malfunction of components and clogging of piping due to residue.

7. DRAIN PIPING WORK

(1) Rig drain piping

- As for drain work, perform piping in such a manner that water can be drained properly.
- Employ a pipe with either the same diameter or with the diameter larger (excluding the raising section) than that of the connecting pipe (PVC pipe, nominal diameter 25 mm, outside diameter 32 mm).
- Keep the drain pipe short and sloping downwards at a gradient of at least 1/100 to prevent air pockets from forming.
- If the drain pipe cannot be sufficiently set on a slope, execute the drain raising piping.
- To keep the drain pipe from sagging, space hanging wires every 1 to 1.5 m.

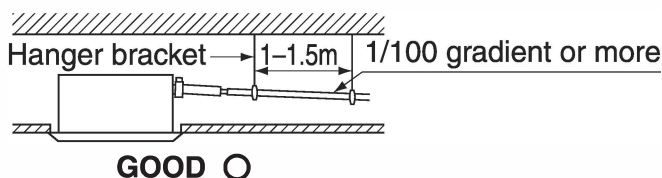

Fig. 18-1

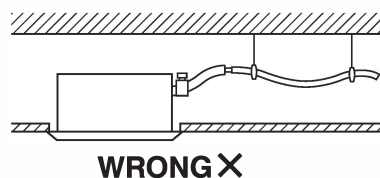

Fig. 18-2

CAUTION

Water accumulating in the drainage piping can cause the drain to clog.

- Use the attached drain hose (1) and Metal clamp (2).
- Insert the drain hose into the drain socket up to the base, and tighten the metal clamp securely within the portion of a white tape of the hose-inserted tip. Tighten the metal clamp until the screw head is less than 4 mm from the hose.
- Wrap the attached sealing pad (10) over the Metal clamp and drain hose to insulate.
- Make sure that heat insulation work is executed on the following 2 spots to prevent any possible water leakage due to dew condensation.
 - Indoor drain pipe
 - Drain socket

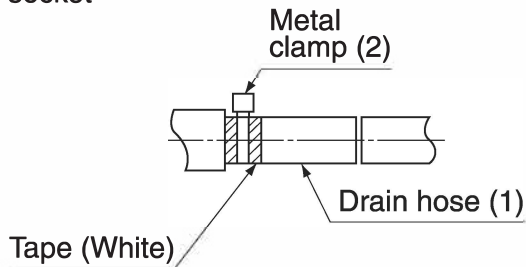

Fig. 19

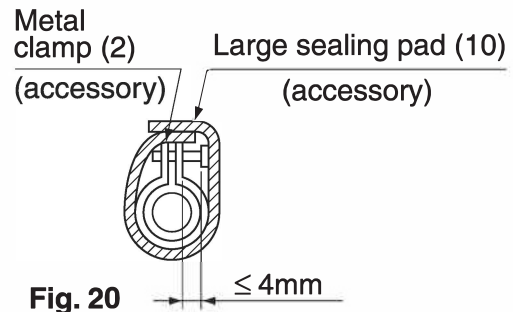

Fig. 20

<PRECAUTIONS FOR DRAIN RAISING PIPING>

- Install the drain raising pipes at a height of less than 675 mm. The drain pump of this unit has a high delivery flow rate. Therefore, the higher the drain raising height is, the lower the sound of draining will be. For this reason, a minimum drain raising height of 300 mm is recommended.
- Install the drain raising pipes at a right angle to the indoor unit and no more than 300 mm from the unit.

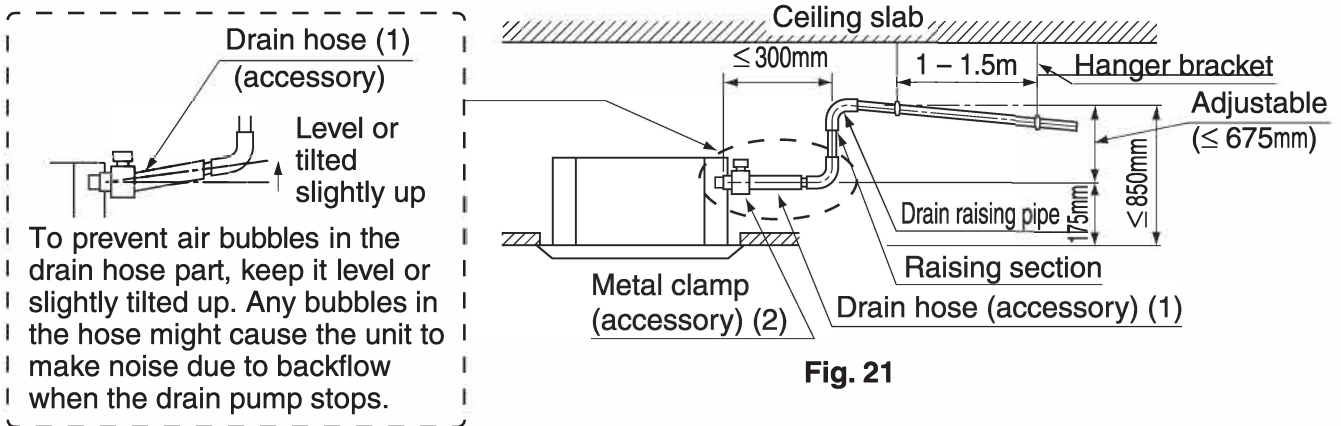

Fig. 21

NOTE

- To ensure no excessive pressure is applied to the included drain hose (1), do not bend or twist when installing. (This may cause leakage.)
- If converging multiple drain pipes, install according to the procedure shown below.

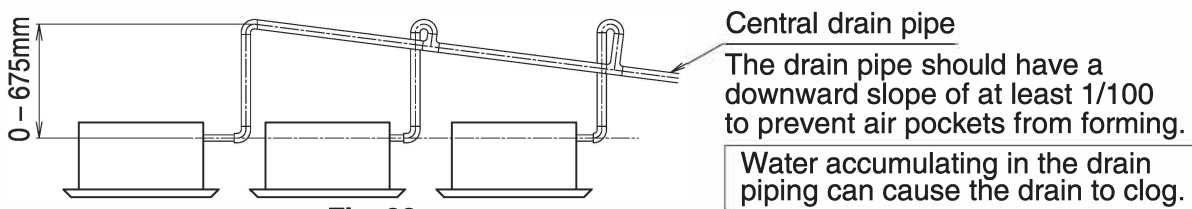

Fig. 22

- As for the size of central drain pipe, select the size that meet the capacity of indoor units to be connected. (Refer to the technical document)
- At replacement with new indoor unit, use the attached new drain hose (1) and the metal clamp (2). If an old drain hose or a metal clamp is used, it may cause water leakage.

CAUTION

Drain piping connections

- Do not connect the drain piping directly to sewage pipes that smell of ammonia. The ammonia in the sewage might enter the indoor unit through the drain pipes and corrode the heat exchanger.

(2) After piping work is finished, check if drainage flows smoothly.

WHEN ELECTRIC WIRING WORK IS FINISHED

- Add approximately 1L of water slowly from the air outlet and check drainage flow. (Refer to Fig.23)
- Check drainage flow during COOL running, explained under “12. TEST OPERATION”.
- Refer to the figure on the following after checking the draining of water, and mount the thermal insulation material for drainage (14) and thermal insulate the drain socket.

⚠ CAUTION

- Do not apply external force to the float switch.
This may result in a malfunction.

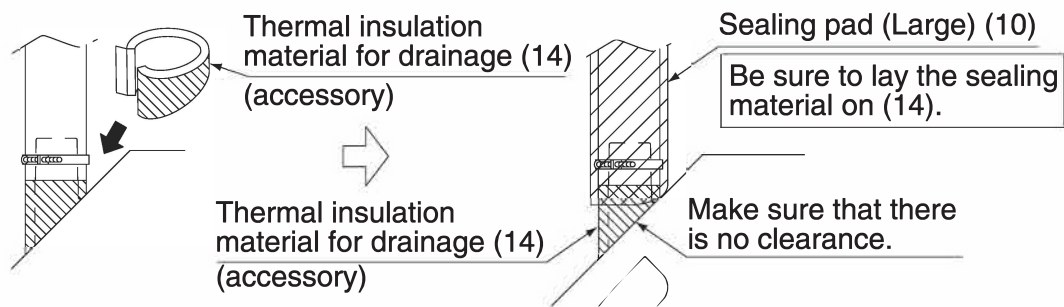

WHEN ELECTRIC WIRING WORK IS NOT FINISHED

⚠ CAUTION

- Electrical wiring work should be done by a certified electrician.
- If someone who does not have the proper qualifications performs the work, perform the following after the test run is complete.

- Remove the control box lid. Connect the single phase power supply (SINGLE PHASE 230V) to connections No.1 and No.2 on the terminal block for wiring the units. Do not connect to No.3 of the terminal block for wiring the units. (The drain pump will not operate.) Connect the earth wire firmly. When carrying out wiring work around the control box, make sure none of the connectors come undone. Be sure to attach the control box lid before turning on the power.
- Put approximately 1L of water into the drain pan through the blow-off mouth on the left-hand side of the drain socket. Make sure not to pour water over the drain pump or any electric parts including those of the drain pump.
- When the power is turned on, the drain pump will operate and you can check the draining of water through the transparent part of the drain socket. (The drain pump will stop automatically in 10 minutes.) After checking the draining of water, mount the thermal insulation material for drainage (14) and thermal insulate the drain socket.
- After confirming drainage (Fig. 23, Fig. 24), turn off the power and remove the power supply.
- Attach the control box lid as before.

⚠ CAUTION

- Do not apply external force to the float switch.
This may result in a malfunction.
- Do not touch the electronic ports other than the terminal block.

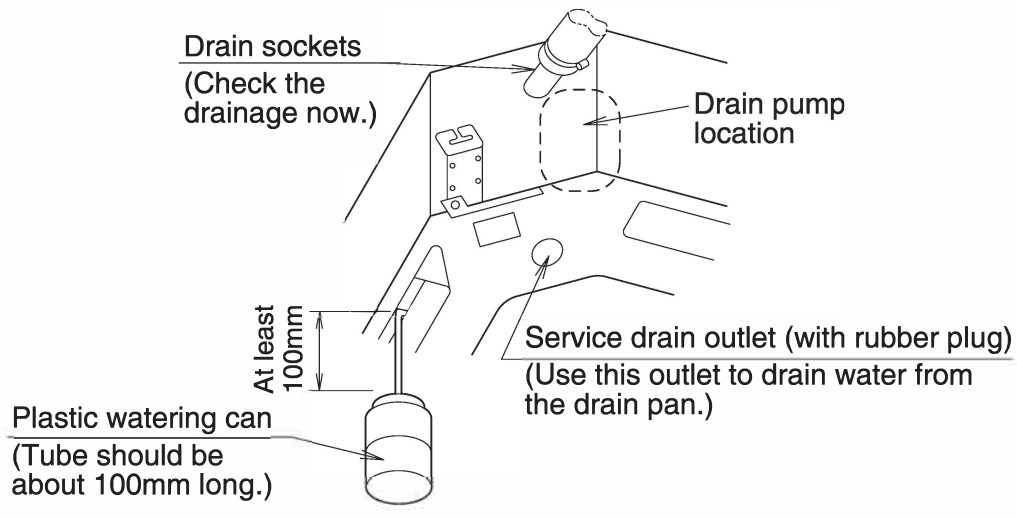

<Adding water through air discharge outlet>
[Method of adding water]

Fig. 23

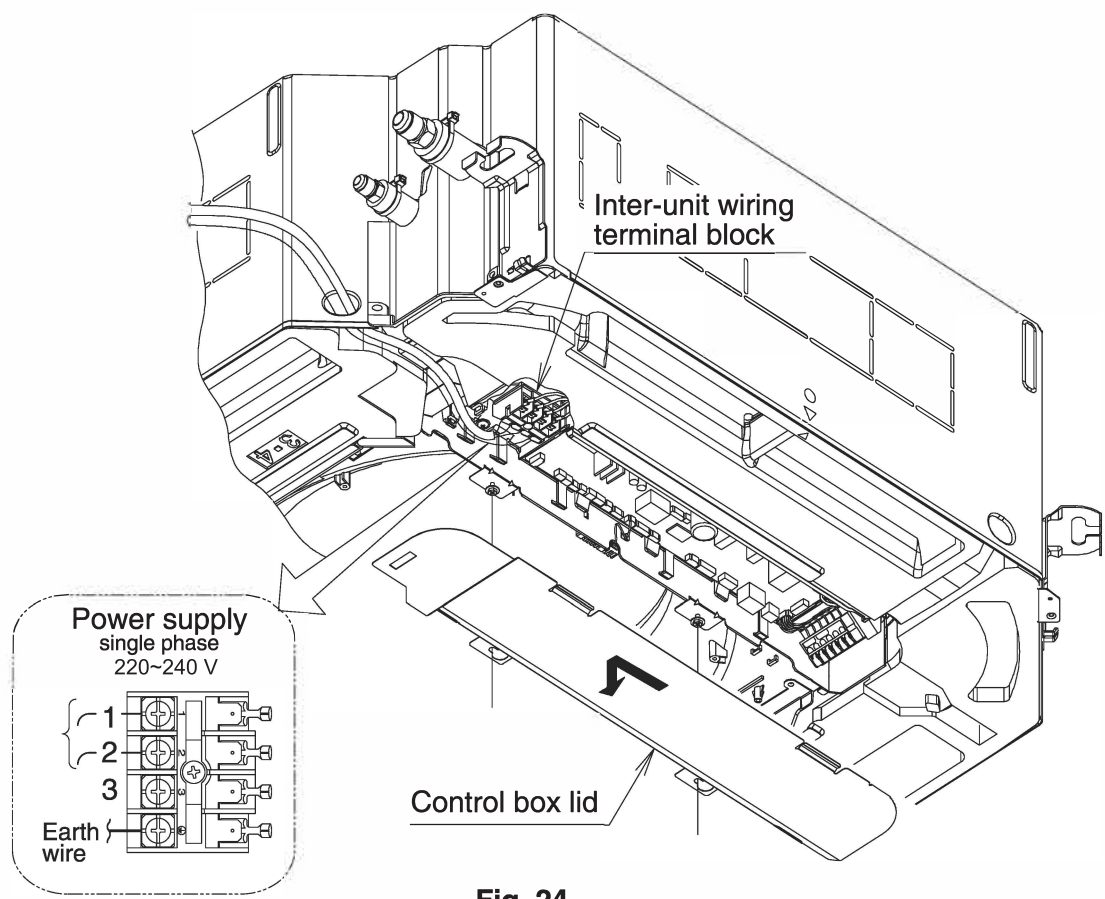

Fig. 24

8. ELECTRIC WIRING WORK

- Electric wiring work must be conducted by electrician authorized by power companies. (Only licensed electrician can conduct electric work and earth connections.)
- All wiring must be performed by an authorized electrician.
- A circuit breaker capable of shutting down power supply to the entire system must be installed.
- Be sure to install an earth leakage circuit breaker to the outdoor unit.

(This installation of an earth leakage circuit breaker is mandatory for the prevention of electric shocks and fire disasters.)

- Make sure that 220~240 V is specified wiring between the indoor and outdoor units and between indoor units.
- Do not turn on the power supply (of the indoor unit) until all the installation work is completed.
- Be sure to ground the air conditioner.
- Refer to the installation manual attached to the outdoor unit for the size of power supply electric wire connected to the outdoor unit, the capacity of the circuit breaker and switch, and wiring instructions.
- Do not connect the earth wire to gas pipes, plumbing pipes, lightning rods, or telephone earth wires.
 - Gas pipes: might cause explosions or fire if gas leaks.
 - Plumbing pipes: no earth effect if hard vinyl piping is used.
 - Telephone earth wires or lightning rods: might cause abnormally high electric potential in the earth during lightning storms.
- For electric wiring work, refer to also “WIRING DIAGRAM” attached to the control box lid.
- Never connect the power supply wire to the terminal block for remote controller wire, or otherwise the entire system may be damaged.
- For remote controller wiring details, refer to the installation manual attached to the remote controller.
- Do not touch the printed circuit board ASSY during the wiring work. Otherwise, it may cause damage.

• Specifications for field wire

Refer to the installation manual attached to the outdoor unit regarding the detail of standard accessories for the outdoor unit.

The remote control cord should be procured locally. Refer to the **Table 5** when preparing one.

Wiring specifications are shown on the condition that the wiring has a voltage drop of 2%.

Table 5

	Wire	Size (mm ²)	Length
Wiring the units	H05VV – U4G (NOTE 1, 2)	2.5	–
Remote controller cord	Vinyl cord with sheath or cable NOTE 3 (2 wire)	0.75 – 1.25	Max. 500m *

*This will be the total extended length in the system when doing group control.

NOTE

1. Shows only in case of protected pipes. Use H07RN-F in case of no protection.
2. Supply cords shall not be lighter than polychloroprene sheathed flexible cord (code designation 60245 IEC 57)
3. Vinyl cord with sheath or cable (Insulated thickness : 1 mm or more)

Connection of wiring between units, earth wire and for the remote controller cord (Refer to Fig. 26)

- Wiring the units and earth wire

Remove the control box lid and connect wires of matching number to the terminal block for wiring the units (4 P) inside. And connect the earth wire to the earth terminal. In doing this, pull the wires inside through the hole and fix the wires securely with the included clamp (4).

- Remote controller cords

Remove the control box lid and pull the wires inside through the hole and connect to the terminal block for remote controller (4 P) (no polarity). Securely fix the remote controller cord with the included clamp (4).

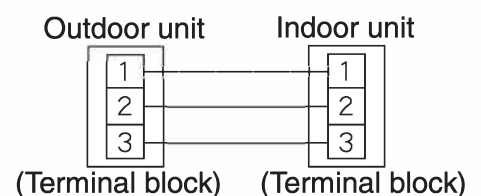

Match both numbers.

How to connect the connection pipe

CAUTION

- Never connect the power supply wiring to the terminal block for wiring the units (4P). If may damage the total system.
- Do not connect the remote controller to the wrong terminal block.

- Protect the wire and the wiring through hole area for wirings of the transmission, earth and the remote controller in order to prevent the intrusion of water and small animals into the air conditioner after the system is wired.
- Cut the sealing pad - small (13) into two pieces and wrap each wiring with each piece.
- Seal the clearance around the wirings with putty or thermal insulation material (field supply). (If insects and small animals get into the indoor unit, short circuiting may occur inside the control box.)
- After all the wiring connections are done, fill in any gaps in the through holes with putty or insulation (procured locally) to prevent small animals and insects from entering the unit from outside. (If any do get in, they could cause short circuits in the control box.)
- Outside the machine, separate the weak wiring (remote controller cord) and strong wiring (interunit, earth, and other power wiring) at least 50 mm so that they do not pass through the same place together. Proximity may cause electrical interference, malfunctions, and breakage.

[Processing method of wiring through hole]

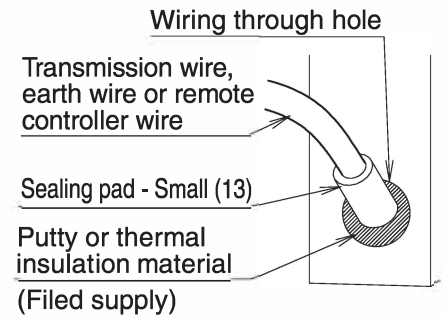

Fig. 25

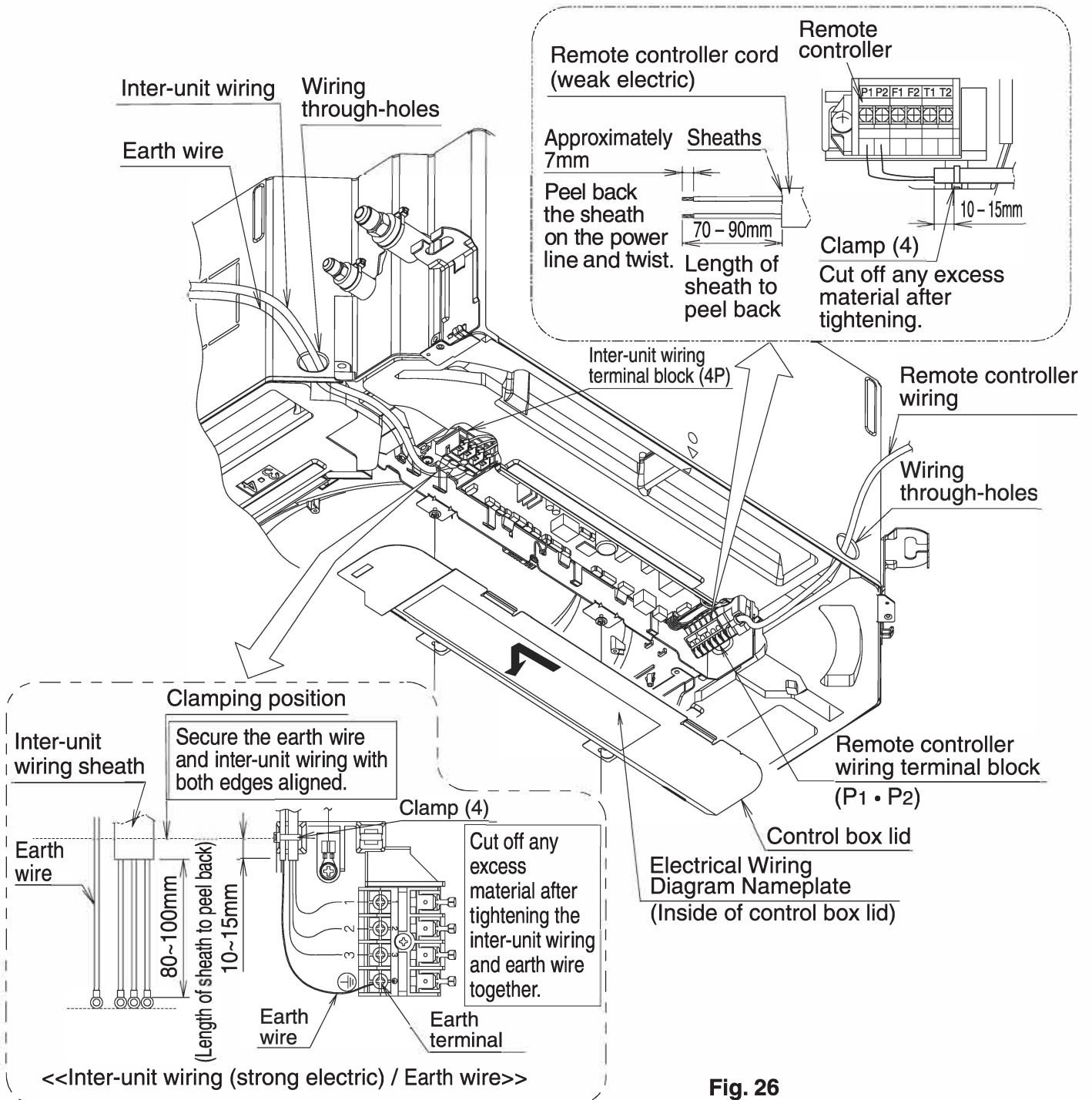

Fig. 26

CAUTION

- Shape the wires and attach the control box lid securely so that wires will not be caught. (Caught wires and risen lid may cause an electric shock or fire.)

Precautions to be taken for power supply wiring

Use a round crimp-style terminal for connection to the power supply terminal block.

In case it cannot be used due to unavoidable reasons, be sure to observe the following instructions.

(Refer to Fig. 27)

- Do not connect wires of different gauge to the same power supply terminal. (Looseness in the connection may cause overheating.) (Refer to Fig. 28)
- When connecting wires of the same gauge, connect them according to. (Refer to Fig. 28)
- In wiring, make certain that prescribed wires are used, carry out complete connections, and fix the wires so that external forces are not applied to the terminals.

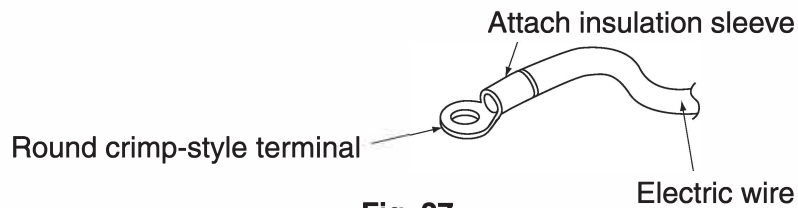
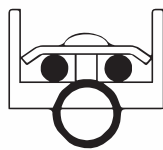

Fig. 27

Connect wires of the same gauge to both side. (GOOD)



Good

Do not connect wires of the same gauge to one side. (WRONG)

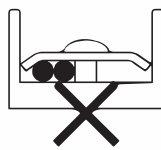

Wrong

Fig. 28

Do not connect wires of different gauges. (WRONG)

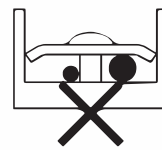

Wrong

Tightening torque for the terminal screws.

- Use the correct screw driver for tightening the terminal screws. If the blade of screwdriver is too small, the head of the screw might be damaged, and the screw will not be properly tightened.
- If the terminal screws are tightened too hard, screws might be damaged.

Refer to the table below for the tightening torque of the terminal screws.

Tightening torque (N·m)	
Terminal block for remote controller	0.88±0.08
Terminal block for wiring the units	1.47±0.14
Earth terminal	1.47±0.14

- If the strand wire is used, do not solder it. (Abnormal heating may occur if the wirings are not tightened securely.)

9. WIRING EXAMPLE

⚠ CAUTION

Be sure to install an earth leakage breaker to the outdoor unit.
Installation of an earth leakage breaker is mandated to avoid electric shocks or fire.

For the wiring of outdoor units, refer to the installation manual attached to the outdoor units.

Confirm the system type.

- **Pair type:** 1 remote controller controls 1 indoor unit. (standard system) (Refer to Fig. 29)
- **Simultaneous operation system:** 1 remote controller controls 2 indoor unit (2 indoor units operates equally). (Refer to Fig.30)
- **Group control:** 1 remote controller controls up to 16 indoor units. (All indoor units operate according to the remote controller) (Refer to Fig. 31)
- **2 remote controllers control:** 2 remote controllers control 1 indoor unit. (Refer to Fig. 33)

Pair type

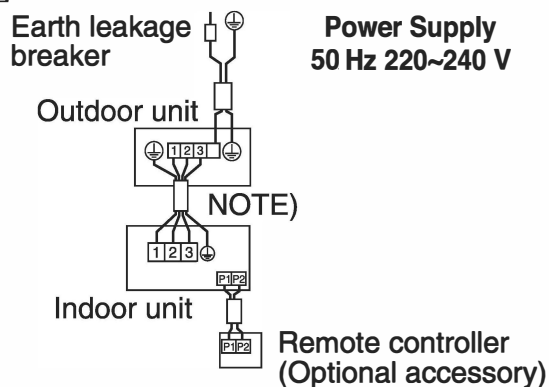

Fig. 29

Standard wiring accessories

Single-phase supply	Indoor unit		
	Earth wire (copper)	Connection wire between indoor unit and outdoor unit	
		Minimum thickness	Length
	$\geq 2.0 \text{ mm}^2$ $\phi 1.6$	2.0 mm^2 $\phi 1.6$	$\leq 50 \text{ m}$

* For wiring length of indoor outdoor connection wiring will be changed depends on connect model, quantity, power size. For details, please refer engineer guide.

Simultaneous operation system

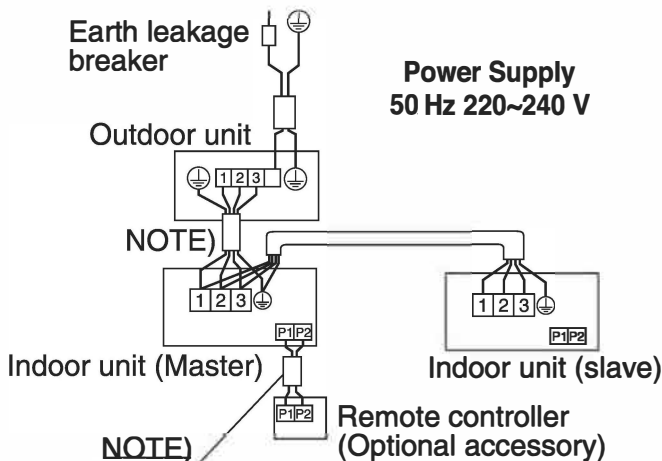

Fig. 30

Simultaneous operation system

- Connect the remote controller only to the master unit.
 - The remote controller needs to be wired only to the master unit, it does not need to be connected to the slave units through transition wiring. (Do not connect transition wiring to the slave units.)
 - The indoor temperature sensor is effective only for indoor units to which the remote controller is connected.
 - The length of wiring between the indoor unit and the outdoor unit varies depending on the connected model, the number of connected units, and the maximum piping length.
- For details, refer to the technical documents.

Group control

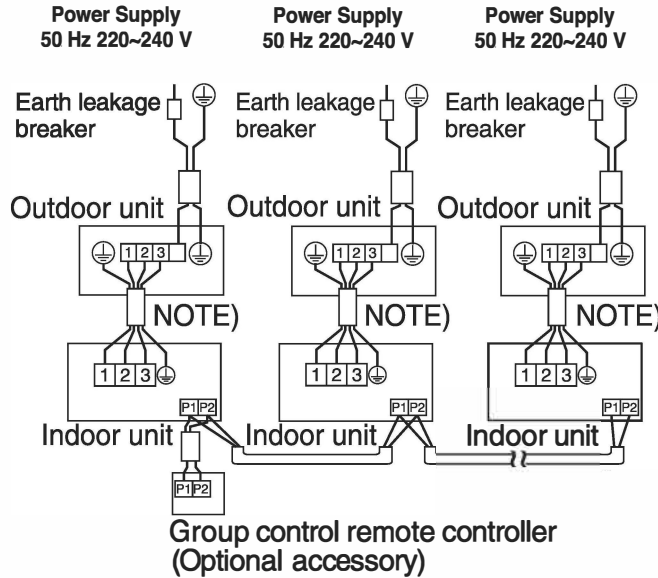

Fig. 31

	Wire	Size (mm ²)	Length
Remote controller cord	Vinyl cord with sheath or cable NOTE 3 (2 wire)	0.75 – 1.25	Max. 500 m *

When implementing group control

- When using as a pair unit or as a parent unit for simultaneous operation multi, you may simultaneous start/stop (group) control up to 16 unit with the remote controller.
- In this case, all the indoor units in the group will operate in accordance with the group control remote controller.
- Select a remote controller which matches as many of the functions (airflow direction, etc.) in the group as possible.

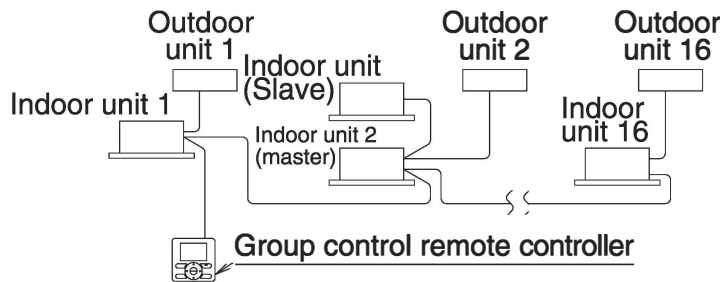

Fig. 32

Wiring Method

- (1) Remove the control box lid. (See “8. ELECTRIC WIRING WORK”.)
- (2) Cross-wire the terminal block for remote controller (P₁, P₂) inside the control box. (There is no polarity.) (Refer to Fig. 30 and Table 5)

2 remote controllers control

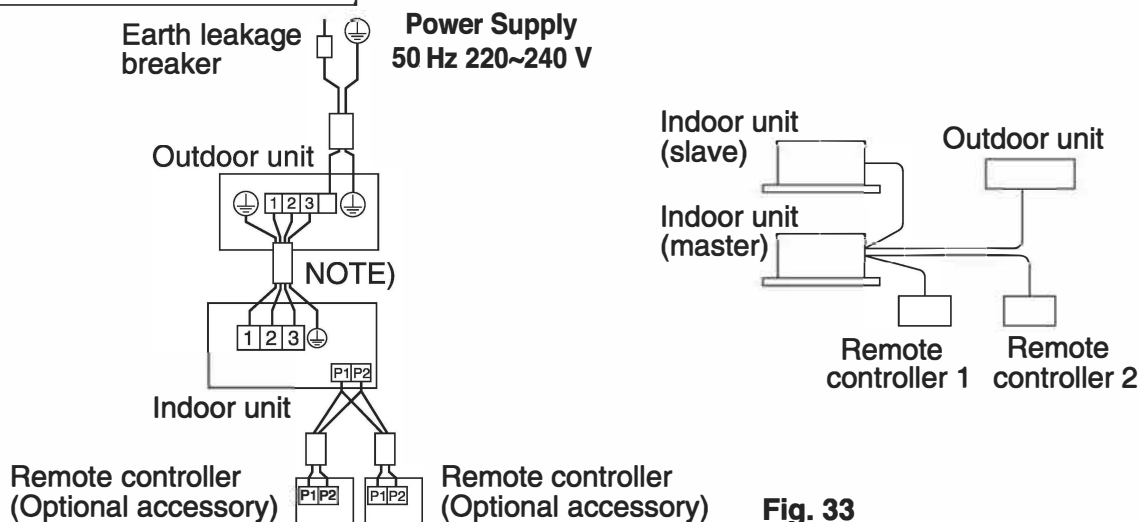

Fig. 33

Two remote controllers control (Controlling 1 indoor unit by 2 remote controllers)

- When using 2 remote controllers, one must be set to “MAIN” and the other to “SUB”.

MAIN/SUB CHANGEOVER

- Refer to the manual attached to the remote controller.

Wiring Method

(1) Remove the control box lid.

(2) Add wiring between the remote controller 2 (Sub) and the terminal (P1, P2) of the terminal block (X1M) for the remote controller in the control box. (There is no polarity.) (Refer to Fig.33 and Table 5)

NOTE

1. All transmission wiring except for the remote controller wires is polarized and must match the terminal symbol.
2. In case of simultaneous operation and group control, perform the remote controller wiring to the master unit when connecting to the simultaneous operation system. (wiring to the slave unit is unnecessary)
3. For group control remote controller, choose the remote controller that suits the indoor unit which has the most functions (as attached swing flap)

10. INSTALLATION OF THE DECORATION PANEL

<If test operation is required before installation of the decoration panel, “11. FIELD SETTING” and “12. TEST OPERATION” can be carried out before “10. INSTALLATION OF THE DECORATION PANEL”.>

- Refer to the installation manual attached to the decoration panel.
- After installing the decoration panel, ensure that there is no space between the unit body and decoration panel.
- When making a test run before installation of the decoration panel, be sure to check the operation of the swing flap after the installation.

11. FIELD SETTING

<<Refer to also the installation manual attached to the outdoor unit.>>

⚠ CAUTION

Before carrying out field setting, check the items mentioned in the clause 2 “1. Items to be checked after completion of work” on page 4.

- Check if all the installation and piping works for the air conditioner are completed.
- Check if the control box lids of the air conditioner are closed.

< FIELD SETTING FOR WIRED REMOTE >

<<After turn on the power supply, carry out field setting from the remote controller according to the installation state.>>

- Carry out setting at 3 places, “Mode No.”, “FIRST CODE No.” and “SECOND CODE No.”. The settings shown by “” in the table indicate those when shipped from the factory.
- The method of setting procedure and operation is shown in the installation manual attached to the remote controller.
(Note) Though setting of “Mode No.” is carried out as a group, if you intend to carry out individual setting by each indoor unit or confirmation after setting, carry out setting with the Mode No. shown in the parenthesis ().
- In case of remote control, for changeover of input to FORCED OFF or to ON/OFF OPERATION.
[1] Enter into the field setting mode with the remote controller.
[2] Select Mode No. “12”.
[3] Set the FIRST CODE No. to “1”.
[4-1] For FORCE OFF, set the SECOND CODE No. to “01”.
[4-2] For ON/OFF OPERATION, set the SECOND CODE No. to “02”.
(It is set to FORCE OFF when shipped from the factory.)
- Ask your customer to keep the manual attached to the remote controller together with the operation manual.
- Do not carry out settings other than those shown in the table.

NOTE: For wireless remote field setting kindly refer the Remote manual.

11-1 SETTING CEILING HEIGHT

- Set the SECOND CODE No. according to the ceiling height as shown in the **Table 6**.

Table 6

		FCFQ-CV1	Mode No. Note) 1	FIRST CODE No.	SECOND CODE No.
		18 type			
Ceiling height (m)	Standard · All round outlet	≤2.7	13 (23)	0	01
	High ceiling 1	2.7 - 3			02
	High ceiling 2	3 - 3.5			03

Note:

1. “Mode No.” setting is done in a batch for the group.
To make or confirm settings for an individual unit, set the internal mode number in parentheses.
2. The figure of the ceiling height is for the all round outlet.
For the settings for four-direction (part of corner closed off), three-direction and two-direction outlets, see the installation manual and technical guide supplied with the separately sold closure material kit.

11-2 SETTING AIR DISCHARGE DIRECTION

- Refer to the installation manual attached to the sealing material of air discharge outlet sold separately and engineering data book, for ceiling height settings for four-direction (part of corner closed off) and three-direction.
(The SECOND CODE No. is factory set to “01” (all round outlet) before shipping.)

11-3 SETTING WHEN AN OPTIONAL ACCESSORY IS ATTACHED

- For setting when attaching an optional accessory, refer to the installation manual attached to the optional accessory.

11-4 WHEN USING WIRELESS REMOTE CONTROLLER

- When using a wireless remote controller, it is necessary to set the wireless remote controller address. Refer to the installation manual attached to the wireless remote controller.

11-5 SETTING FAN SPEED DURING THERMOSTAT OFF

- Set the fan speed according to the using environment after consultation with your customer.
- When the fan speed is changed, explain the set fan speed to your customer.

Table 7

Setting		Mode No.	FIRST CODE No.	SECOND CODE No.
Fan operates / stops during thermo OFF (Cooling · heating)	Operates	11 (21)	2	01
	Stops			02
Fan speed during cooling thermostat OFF	(Extra low)	12 (22)	6	01
	Setting			02

11-6 SETTING FILTER SIGN

- A message to inform the air filter cleaning time will be indicated on the remote controller.
- Set the SECOND CODE No. shown in the **Table 8** according to the amount of dust or pollution in the room.
- Though the indoor unit is equipped with the long life filter, it is necessary to periodically clean the filter to avoid clogging of the filter. Please also explain the set time to the customer.
- The periodical filter cleaning time can be shortened depending on the environment.

Table 8

Contamination	Hours until indication	Mode No.	FIRST CODE No.	SECOND CODE No.
Normal	Approx. 2500 hrs	10 (20)	0	01
More contaminated	Approx. 1250 hrs			02
With indication			3	01
No indication*				02

* Use "No indication" setting when cleaning indication is not necessary such as the case of periodical cleaning being carried out.

11-7 SETTING NUMBER OF THE CONNECTED INDOOR UNITS AS SIMULTANEOUS OPERATION SYSTEM

- When using in simultaneous operation system mode, change the SECOND CODE No. as shown in **Table 9**.
- When using in simultaneous operation system mode, refer to "SIMULTANEOUS OPERATION SYSTEM INDIVIDUAL SETTING" section to set master and slave units separately.

Table 9

Setting	Mode No.	FIRST CODE No.	SECOND CODE No.
Pair system (1 unit)	11 (21)	0	01
Simultaneous operation system (2-unit)			02
Simultaneous operation system (3-unit)			03
Double twin multi (4-unit)			04

11-8 SIMULTANEOUS OPERATION SYSTEM INDIVIDUAL SETTING

It is easier if the optional remote controller is used when setting the slave unit.

< Procedure >

- Perform the following procedure when setting the master and slave unit separately.
 - “ ” in the tables indicates factory settings.
- (Note) The “Mode No.” is set on a group basis. To individually set a Mode No. for each indoor unit or confirm the settings, set the Mode No. in the parenthesis.

(1) Change the SECOND CODE No. to “02”, individual setting, so that the slave unit can be individually set.

Setting	Mode No.	FIRST CODE No.	SECOND CODE No.
Unified setting	11 (21)	1	01
Individual setting			02

- Perform field setting (Refer to 11-1 to 11-5) for the master unit.
 - Turn off the main power supply switch after (2) is finished.
 - Detach remote controller from the master unit and connect it to the slave unit.
 - Turn on the main power supply switch again, and as in (1), change the SECOND CODE No. to “02”, individual setting.
 - Perform field setting (Refer to 11-1 to 11-4) for the slave unit.
 - Turn off the main power supply switch after (6) is finished.
 - If there is more than one slave unit, repeat steps (4) to (7).
 - Detach the remote controller from the slave unit after the setting, and reattach to the master unit.
- This is the end of the setting procedure.

* You do not need to rewire the remote controller from the master unit if the optional remote controller for slave unit is used. (However, remove the wiring attached to the remote controller terminal block of the master unit.) After the slave unit setting, remove the remote controller wiring, and rewire the remote controller to the master unit. (The indoor unit does not operate properly when two or more remote controllers are attached to the unit in the simultaneous operation system mode.)

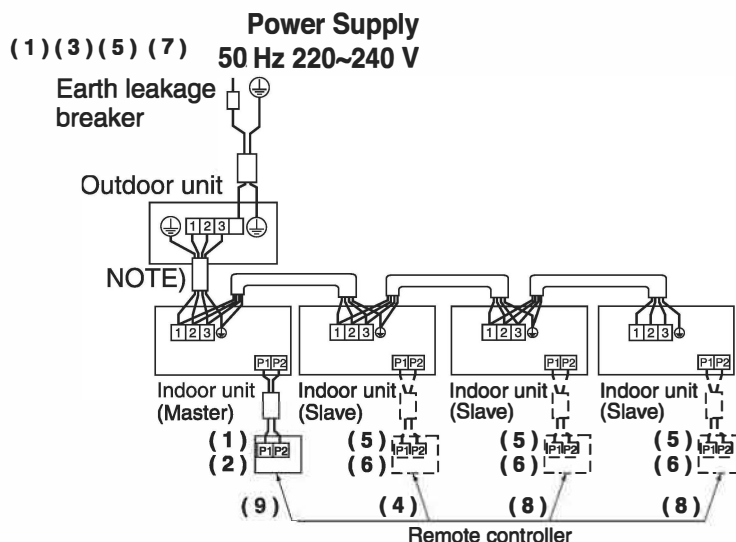

NOTE

- Terminal numbers of outdoor and indoor units must be matched.

12. TEST OPERATION



CAUTION

When performing field setting or test operation without attaching the decoration panel, do not touch the drain pump. This may cause electric shock.

<Complete all the “1. Items to be checked after the installation work is completed” on page 4. Please also refer to the installation manual attached to outdoor unit.>

Refer to the section of “FOR THE FOLLOWING ITEMS, TAKE SPECIAL CARE DURING CONSTRUCTION AND CHECK AFTER INSTALLATION IS FINISHED.” .

- After finishing the construction of refrigerant piping, drain piping, and electric wiring, conduct test operation accordingly to protect the unit.
- Check that the outdoor unit has been wired properly.
- Check that the control box lid of the indoor unit is closed and that the outer plate and piping cover of the outdoor unit are closed as well.
- Clean the decoration panel and interior of the indoor unit on completion of refrigerant piping, drain piping, and electric wiring work.
- Refer to the installation manual of the outdoor unit, and perform the test operation of the air conditioner.
- If the decoration panel is mounted at the time of test operation, check the operation of the swing flap of the decoration panel.
- If the interior finishing work has been still on the way on completion of test operation, explain to the customer not to operate the air conditioner for the protection of the indoor unit until the interior finishing work is completed.

If the air conditioner is operated, substances generated from the paint and glue of the interior finishing will contaminate the indoor unit, thus resulting in water splashing or leakage.

- If an error occurs and the air conditioner does not operate, refer to the troubleshooting information provided in the installation manual attached with remote controller.

NOTE

- If a malfunction is preventing operation, refer to the malfunction diagnoses.

12-1 CAUTIONS FOR SERVICING

With the power on. Troubles can be monitored on the remote controller.

- If the air conditioner does not operate normally after installing the air conditioner, a malfunction shown in the table below may happen.

Remote controller display	Malfunction
No display	<ul style="list-style-type: none">• Power supply trouble or Open phase connection• Wrong wiring between indoor and outdoor unit• Indoor PC board faulty• Wrong remote controller connection wiring• Remote controller faulty• Fuse faulty

*After turning on the power, the maximum is 90 seconds, although it will only display "Checking the connection. Please stand by". This is not a problem, and it will be set for 90 seconds.

** For fault diagnosis for BRC1H model remote controller should be performed while referring to the indoor operation manual.

12-2 MALFUNCTION CODE LIST

- For places where the Malfunction code is left blank, the “” indication is not displayed. Though the system continues operating, be sure to inspect the system and make repairs as necessary.
- Depending on the type of indoor or outdoor unit, the Malfunction code may or may not be displayed.

Code	Malfunction/Remarks
A0	Safety device operates
A1	Indoor unit's PC board faulty
A3	Drain water level abnormal
A6	Indoor fan motor overloaded, overcurrent or locked
A8	Fan PCB power supply error
AF	Humidifier faulty
AH	Air cleaner faulty
	Only the air cleaner does not function.
AJ	Type set improper
	Capacity data is wrongly preset. Or there is nothing programmed in the data hold IC.
C1	Indoor PCB (Master) - indoor PCB (Slave) transmission defect
C4	Sensor (R2T) for heat exchanger temperature is fault
C5	Sensor (R3T) for heat exchanger temperature is fault
C6	Fan PCB setting defect
C9	Sensor for suction air temperature is fault
CC	Humidity sensor abnormal
CE	Human detection / floor temperature sensor error
CJ	Sensor for remote controller is fault
	The remote controller thermistor does not function, but the system thermo run is possible.
E0	Action of safety device (outdoor unit)
E1	Outdoor unit's PC board faulty
E3	High pressure abnormal (outdoor unit)
E4	Low pressure abnormal (outdoor unit)
E5	Compressor motor lock malfunction
E7	Outdoor fan motor lock malfunction
	Outdoor fan instantaneous overcurrent malfunction
E9	Electronic expansion valve faulty (outdoor unit)
EA	Error from defect of change 4 way valve (outdoor)
F3	Discharge pipe temperature abnormal (outdoor unit)
H3	High pressure switch faulty (outdoor unit)
H4	Low pressure switch faulty (outdoor unit)
H7	Outdoor motor position signal malfunction
H9	Outdoor air thermistor faulty (outdoor unit)
	Equipment operation in response to errors will vary according to model.
JA	Discharge pipe pressure sensor faulty (outdoor unit)
JC	Suction pipe pressure sensor faulty (outdoor unit)
J1	Pressure sensor system error (batch) (outdoor unit)
J2	Power sensor system error (outdoor unit)
J3	Discharge pipe thermistor faulty (outdoor unit)
	Equipment operation in response to errors will vary according to model.
J5	Suction pipe thermistor faulty (outdoor unit)
J6	Heat exchanger thermistor faulty (outdoor unit)
	Equipment operation in response to errors will vary according to model.

J7	Heat exchanger thermistor faulty (outdoor unit)
	Equipment operation in response to errors will vary according to model.
J8	Liquid piping temperature sensor system error (outdoor unit)
J9	Intake temperature sensor error (outdoor unit)
L1	Inverter system error (outdoor unit)
L3	Reactor thermister error (outdoor)
L4	Overheated heat-radiating fin (outdoor unit)
	Inverter cooling defect.
L5	Instantaneous overcurrent (outdoor unit)
	Possible earth fault or short circuit in the compressor motor.
L8	Electric thermal (outdoor unit)
	Possible electrical overload in the compressor or cut line in the compressor motor.
L9	Stall prevention (outdoor unit)
	Compressor possibly locked.
LC	Transmission malfunction between the outdoor control units' inverters (outdoor unit)
P1	Open-phase (outdoor unit)
P3	P-board temperature sensor malfunction (outdoor unit)
P4	Heat-radiating fin temperature sensor malfunction (outdoor unit)
P6	DC output current error (outdoor)
PJ	Type set improper (outdoor unit)
	Capacity data is wrongly preset. Or there is nothing programmed in the data hold IC.
U0	Suction pipe temperature abnormal
U1	Reverse phase
	Reverse two phase of the L1, L2 and L3 leads.
U2	Power source voltage malfunction (outdoor unit)
	Includes the defect in 52C.
U4 UF	Transmission error (indoor unit – outdoor unit)
	Wrong wiring between indoor and outdoor units or malfunction of the PC board mounted on the indoor and the outdoor units.
U5	Transmission error (indoor unit – remote controller)
	Transmission is improper between the indoor unit and the remote controller.
U8	Malfunction in transmission between main and sub remote controls. (Malfunction in sub remote controller.)
UA	Miss setting for multi system
	Setting is wrong for selector switch of multi - system. (see switch SS2 on the main unit's PC board)
UC	Central control address overlapping
UE	Transmission defect (indoor - centralizing)
UJ	Peripheral equipment transmission fault

⚠ CAUTION

- Refer to “**2. Items to be checked at time of delivery**” on page 4 upon completion of the test run and make sure that all the items are checked.
- If the customer’s interior work has not been finished on completion of the test run, explain the customer not to operate the air conditioner. This is essential until the interior work is finished so as to protect the product. Substances generated from paints and adhesives used for the interior work may contaminate the product if the unit is operated.

⚠ To test run Contractors

When delivering the product to the customer after the test run is completed, check that the control box lid, the air filter and the suction grille are mounted. In addition, explain to the customer regarding the state (ON/OFF) of the power supply breaker.

14. UNPACKING & PACKING OF THE INDOOR

14-1. UNPACKING

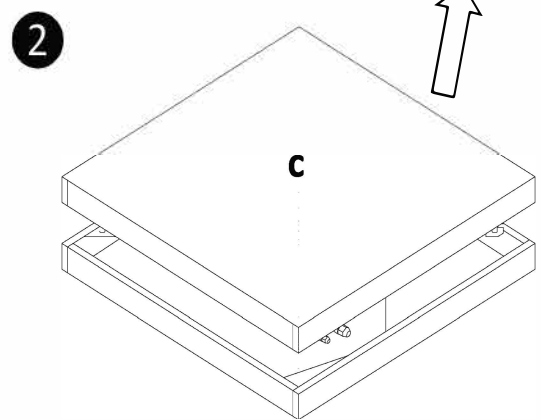
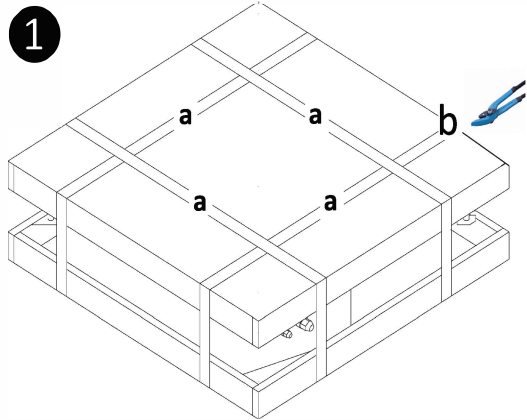

- Cut all the straps (a) from the unit using strap cutter (b) as shown in figure.

- a) Strap
- b) Strap cutter
- c) Top corrugated cardboard sheet with EPS
- d) Product cover
- e) Bottom corrugated cardboard sheet with EPS
- f) Pad
- g) Accessories set

- Remove top corrugated cardboard sheet (c) & EPS from the unit by pulling it up as shown in figure.

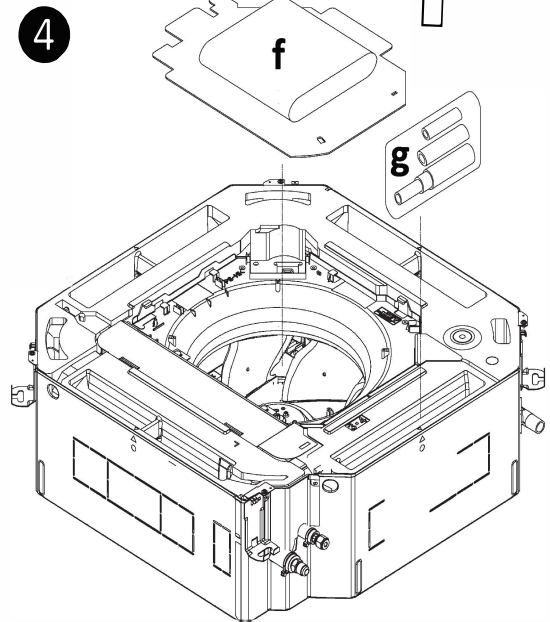
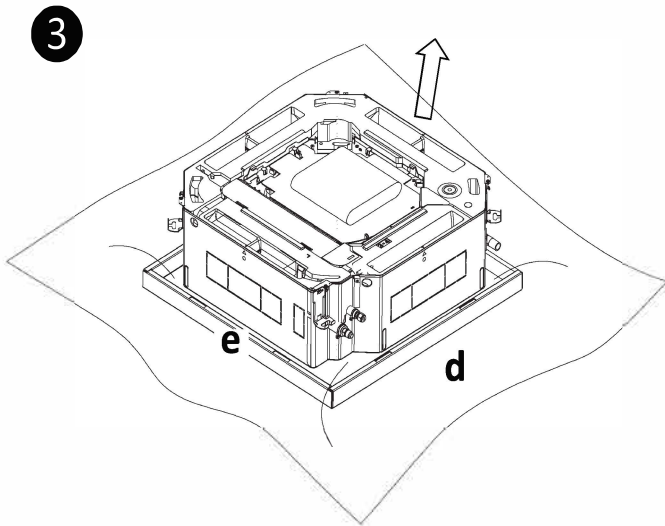

- Unfold the Product Cover (d) and pull the unit up, then remove the Sheet Cover (d) and Bottom corrugated cardboard sheet(e).

- Put the pad (f) and accessories kit (g) off the product as shown in figure.

14-2. PACKING

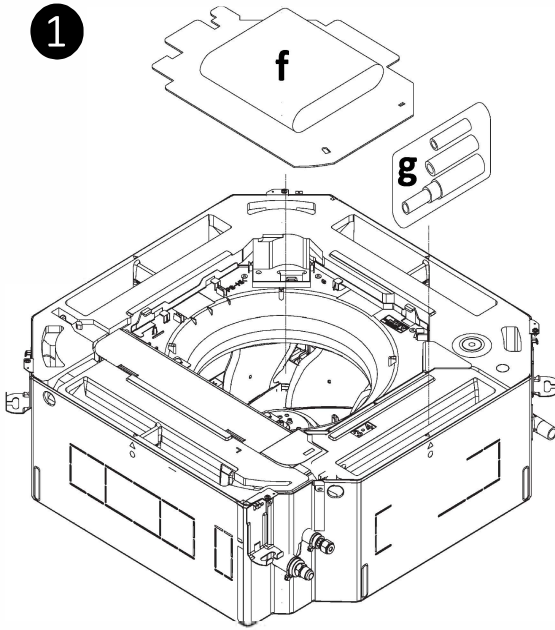

- Put the pad (f) and accessories kit (g) on the product as shown in figure.

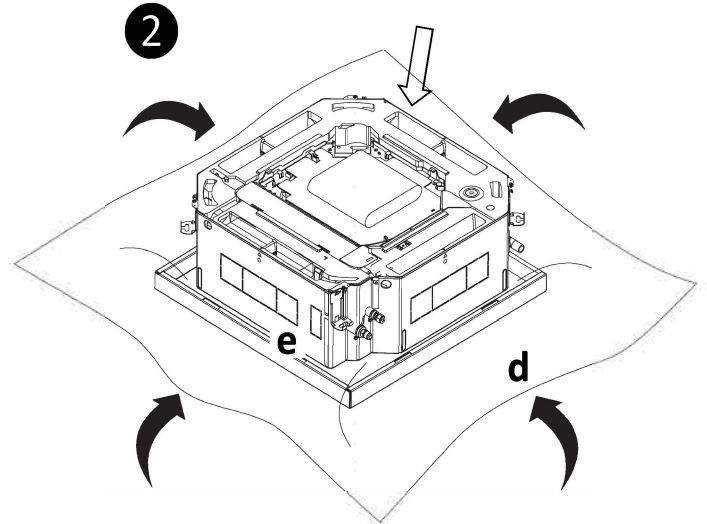

- Put the product on the bottom corrugated cardboard sheet with EPS Pad and product cover. Then fold the product cover on the product.

- | | |
|----|--|
| a) | Strap |
| b) | Strap cutter |
| c) | Top corrugated cardboard sheet with EPS |
| d) | Product cover |
| e) | Bottom corrugated cardboard sheet with EPS |
| f) | Pad |
| g) | Accessories set |
| h) | Strap fixer |

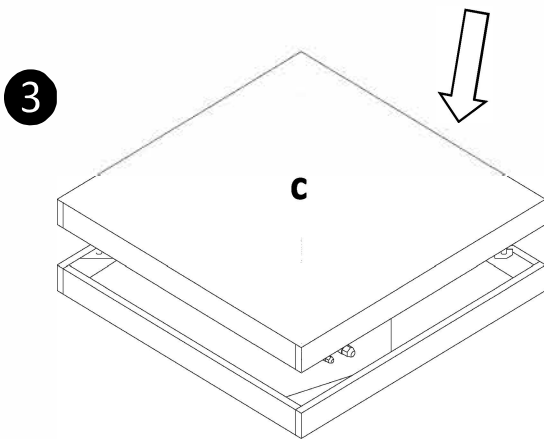

- Put the top corrugated cardboard sheet (c) & EPS on the product as shown in figure.

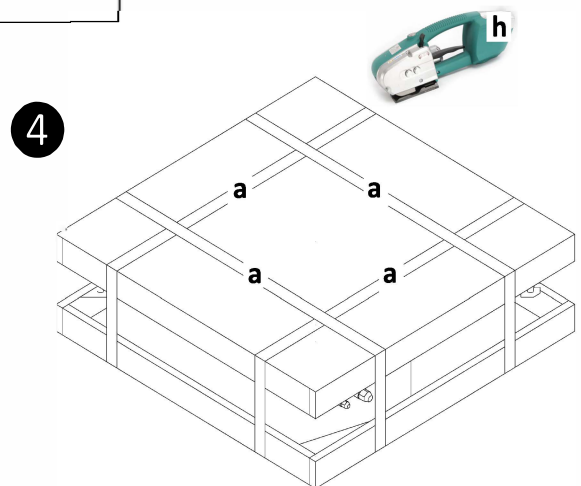

- Cut all the straps (a) from the unit using strap cutter (b) as shown in figure.

SPLIT SYSTEM AIR CONDITIONER

INSTALLATION MANUAL <FOR OUTDOOR UNIT>

READ THESE INSTRUCTIONS CAREFULLY BEFORE INSTALLATION.

NEW REFRIGERANT (R32) SERIES

RZCFQ24CV1

Note :  Read the precautions in this manual carefully before operating the unit.

 This appliance is filled with R32.

CONTENTS

※ SAFETY PRECAUTIONS.....	33
1. BEFORE INSTALLATION.....	35
2. SELECTING INSTALLATION SITE.....	35
3. INSTALLATION SERVICE SPACE.....	36
4. PRECAUTIONS ON INSTALLATION.....	39
5. REFRIGERANT PIPING WORK.....	39
6. AIRTIGHTNESS TEST AND AIR-PURGE.....	42
7. CHARGING REFRIGERANT.....	43
8. ELECTRICAL WIRING WORK.....	44
9. CHECK ITEMS BEFORE TEST OPERATION AND FIELD SETTINGS.....	47
10. TEST OPERATION.....	48
11. CAUTION.....	49
12. HOW TO RE-USE THE EXISTING PIPING.....	50
13. REFRIGERANT RECOVERY.....	51
14.UNPACKING & PACKING OF THE OUTDOOR UNIT.....	52

WARNING THERE IS A RISK OF EXPLOSION OR FIRE

- Do not mix air in the refrigerating cycle during pump down operation.
- Do not use oxygen for air tight test.
- Do not use refrigerant other than the specified one or flammable material (e.g. propane) in the refrigerant cycle. They may cause over pressure in the refrigerating cycle and result in explosion, fire or injury. Our company assumes no responsibility for failure or malfunction caused by filling or mixing of anything other than the specified refrigerant.

CAUTION ABOUT ISOLATING RESISTANCE OF COMPRESSOR

If refrigerant accumulates in the compressor after completing installation, the insulation resistance can drop, but if it at least 1 MΩ, then the unit will not break down.

- Connect the power supply to the unit and after 6 hours check if the insulation resistance of the compressor rises. (Energize and heat the compressor to vaporize the refrigerant accumulated in the compressor.)
- If the earth leakage breaker actuates, check if the earth leakage breaker is equipped with a device to cope with high harmonics. To prevent wrong actuation of the earth leakage breaker due to the inverter, make sure to adopt an earth leakage breaker equipped with a device to cope with high harmonics.

1. Please make sure to confirm that R32 (new refrigerant) is used in installation work in advance. (It may not operate normally, if refrigerant type is different.)
2. The refrigerant R32 requires that strict precautions be observed for keeping the system clean, dry and tightly sealed.
 - Clean and dry
Strict measures must be taken to keep impurities (Including SUNISO oil and other mineral oils as well as moisture) out of the system.
 - Tightly sealed
R32 contains no chlorine, does not destroy the ozone layer and so does not reduce the earth's protection against harmful ultraviolet radiation. R32 will contribute only slightly to the greenhouse effect if released into the atmosphere. Therefore, sealing tightness is particularly important in installation.

Carefully read the chapter **(5) REFRIGERANT PIPING WORK** and strictly observe the correct procedures.

3. The design pressure of this unit : High/Low pressure area are shown in the right table.
The refrigerant piping is a high pressure area,
Use the refrigerant piping which supports the design pressure.
The piping specifications, please refer to chapter

(5) REFRIGERANT PIPING WORK

4. Be sure to connect the indoor unit, which is dedicated to R32. See the catalog for indoor unit models which can be connected.



(Normal operation is not possible when connected to other units.)

Outdoor Unit	Design Pressure	
	RZCFQ24CV1	High
	Low	2.30

(Units: MPa)

READ THESE INSTRUCTIONS CAREFULLY BEFORE INSTALLATION

- This manual classifies the precautions into WARNINGS and CAUTIONS. Be sure to follow all the precautions below. They are all important for ensuring safety.

 WARNING	Indicates a potentially hazardous situation which, if not avoided, could result in death or serious injury.
 CAUTION	Indicates a potentially hazardous situation which, if not avoided, may result in minor or moderate injury. It may also be used to alert against unsafe practices.

- After the installation is completed, test the air conditioner and check if the air conditioner operates properly. Given the user adequate instructions concerning the use and cleaning of the indoor unit according to the operation manual. In particular, make sure to explain with regard to "SAFETY PRECAUTIONS" and "Not malfunction of the air conditioner". Ask the user to keep this manual and the operation manual together in a handy place for future reference.
- This air conditioner comes under the term "appliances not accessible to the general public".

WARNING

- Ask your local dealer or qualified personnel to carry out installation work. Improper installation may result in water leakage, electric shocks or a fire.
- Perform installation work in accordance with this installation manual. Improper installation may result in water leakage, electric shocks or a fire.
- Consult your local dealer regarding what to do in case of refrigerant leakage. When the indoor unit is installed in a small room, it is necessary to take proper measures so that the amount of any leaked refrigerant does not exceed the concentration limit in the event of a leakage. Otherwise, this may lead to an accident due to oxygen deficiency.
- Be sure to use only the specified parts and accessories for installation work. Failure to use the specified parts may result in the air conditioner fall down, water leakage, electric shocks, a fire, etc.
- Install the air conditioner on a foundation that can withstand its mass. Insufficient strength may result in the air conditioner fall down and causing injury.
- Carry out the specified installation work in consideration of strong winds, typhoons, or earthquakes. Improper installation may result in an accident such as the air conditioner falling.
- Make certain that all electric work is carried out by qualified personnel according to the applicable legislation (note 1) and this installation manual, using a separate circuit. In addition, even if the wiring is short, make sure to use a wiring that has sufficient length and never connect additional wiring to make the length sufficient. Insufficient capacity of the power supply circuit or improper electric construction may lead to electric shocks or a fire.
(note 1) Applicable legislation means "All international, national and local directives, laws, regulations and/or codes which are relevant and applicable for a certain product or domain."
- Earth the air conditioner. Do not connect the earth wiring to gas or water piping, lightning conductor or telephone earth wiring. Incomplete earthing may cause electric shocks or a fire. 
- Be sure to install an earth leakage circuit breaker. Failure to do so may cause electric shocks or a fire.
- The appliance must be stored in a room without continuously operating ignition sources (for example : open flames, an operating gas appliance or an operating electric heater).
- Do not pierce or burn.
- Be aware that refrigerant may not contain an odor.
- Comply with national gas regulations.
- Be sure to switch off the unit before touching any electrical parts. Touching a live part may result in electric shocks.
- Make sure that all wiring is secure, using the specified wiring and ensuring that external forces do not act on the terminal connections or wiring. Incomplete connection or fixing may cause overheating terminals or fire.
- When wiring between the outdoor and indoor units, and wiring the power supply, from the wiring orderly so that the structural parts such as a cover can be securely fastened. If the cover is not in place, electric shocks or a fire may be caused.
- Do not add wiring. It may result in heat generation. Electric shocks or fire.
- When installing or relocating the air conditioner, be sure to bleed the refrigerant circuit to ensure, it is free of air, and use only the specified refrigerant (R32). The presence of air or other foreign matter in the refrigerant circuit causes abnormal pressure rise, which may result in equipment damage and even injury.
- If refrigerant gas leaks during installation work, ventilate the area immediately. Toxic gas may be produced if refrigerant gas comes into contact with a fire.
- After completing the installation work, check to make sure that there is no leakage of refrigerant gas. Toxic gas may be produced if refrigerant gas leaks into the room and comes into contact with a source of a fire, such as a fan heater, stove or cooker.
- Never directly touch any accidental leaking refrigerant. This could result in severe wounds caused by frostbite.
- Do not stand on the outdoor unit or put things on it. The unit may fall down or drop, and cause accidents.
- Do not charge any refrigeration into the refrigeration cycle other than the designated refrigerant. It may cause an explosion or a fire due to leakage or a burst due to abnormally high pressure in the refrigeration cycle.
- Do not extend wiring on the way. It may cause heat generation, electric shocks or fire.
- At the installation work, install the refrigerant piping firmly before operating the compressor. If the compressor is operated without installing firmly and the service valve is in open condition, it sucks the air, etc., and the pressure inside the refrigerant circle becomes abnormally high. It may cause injury and breakage.
- At pump down work, stop the compressor before removing the refrigerant piping. If removing the refrigerant piping when the compressor is operated with its service valve in open condition, it sucks the air, etc., and the pressure inside the refrigerant circle become abnormally high, which may cause injury and breakage.
- The appliance (RZF18BVMK) shall be installed operated and stored in a room with floor area larger 1.84 m².
- When flared joints are reused, the flare part shall be re-fabricated.

⚠ CAUTION

- Install drain piping according to this installation manual to ensure good drainage, and insulate the piping to prevent condensation. Improper drain piping may cause water leakage, make the furniture get wet.
- Install the indoor and outdoor units, power cord and connecting wires at least 1 meter away from televisions or radio to prevent picture interference and noise. (Depending on the incoming signal strength, a distance of 1 meter may not be sufficient to eliminate noise.)
- Install the indoor unit as far as possible from fluorescent lamps.
- In a domestic environment this product may cause radio interference in which case the user may be required to take adequate measures.
- Make sure to provide for adequate measures in order to prevent that the outdoor unit be used as a shelter by small animals. Small animals making contact with electrical parts can cause malfunctions, smoke or fire. Please instruct the customer to keep the area around the unit clean.
- Disposal requirements
Dismantling of the unit, treatment of the refrigerant, of oil and of other parts must be done in accordance with relevant local and national legislation.
- Only qualified personnel can handle, fill, purge and dispose of the refrigerant.
- Do not install the air conditioner in places such as following:
 1. Where there is mist of oil, oil spray or vapor for example a kitchen.
Resin parts may deteriorate, and cause them to fall out or water to leak.
 2. Where corrosive gas, such as sulfurous acid gas, is produced.
Corrosion of copper pipings or brazed parts may cause the refrigerant to leak.
 3. Where there is machinery which emits electromagnetic waves.
Electromagnetic waves may disturb the control system, and cause malfunction of the equipment.
 4. Where flammable gases may leak, where carbon fiber or ignitable dust is suspended in the air or where volatile flammables, such as thinner or gasoline, are handled. If the gas should leak and remain around the air conditioner, it may cause ignition.
 5. The place that the vibration or the voltage fluctuation give influence. Vehicles, vessels, etc.
The vibration may cause a damage and the voltage fluctuation may cause an abnormal operation.
 6. Where small animals may build a nest, fallen leaves are accumulated, or weeds are overgrown.
If small animals touch the electrical parts inside, this may cause malfunction, smoke or a fire.

■ Important information regarding the refrigerant used
This product contains fluorinated greenhouse gases covered by the Kyoto Protocol. Do not vent gases into the atmosphere.
Refrigerant type: R32
GWP⁽¹⁾ value: 675
• ⁽¹⁾GWP = global warming potential
The refrigerant quantity is indicated on the unit name plate.

1 BEFORE INSTALLATION

<DO NOT THROW AWAY ACCESSORIES FOR INSTALLATION>

⚠ CAUTION

- Read these instructions carefully before installation.
For installation of the indoor unit, refer to the indoor unit installation manual.

RZCFQ24CV1

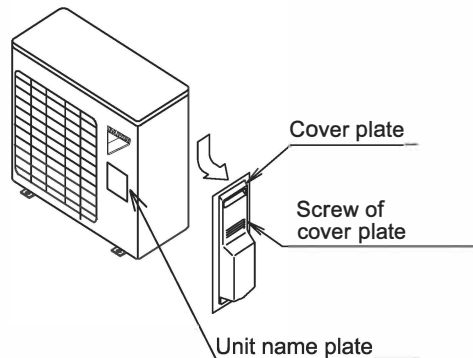

HANDLING

As shown in the figure, bring the unit slowly by grabbing the left and right grips. (Take care not to let hands or objects come in contact with rear fins.)

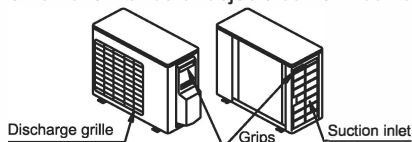

Place your hands on the corner instead of holding the suction inlet in the side of the casing, otherwise the casing could be deformed.

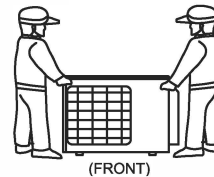

(FRONT)

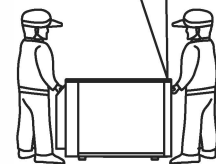

(BACK)

INSTALLATION CONSTRUCTION ACCESSORIES

Be sure only to use accessories made by DAIKIN which are specifically designed for use with the equipment.

CAUTION

Work in a team of at least two people when carrying the outdoor unit

2 SELECTING INSTALLATION SITE (1/2)

- (1) Select the installation location that meets the following conditions and get approval of the customer.
 - Places where there is no risk of flammable gas leakage.
 - Places where the outdoor unit does not bother next-door neighbors.
 - Safe places which can withstand the unit's mass and vibration and where the air conditioner can be installed level.
 - Places that are well-ventilated and where servicing space can be well ensured.
The minimum required space is shown in chapter **3** INSTALLATION SERVICE SPACE
 - Where the piping length between the indoor and the outdoor units is ensured within the allowable piping length. Please see chapter **5** REFRIGERANT PIPING WORK
 - Do not allow wind from the same direction to blow frequently toward the outlet or inlet of the outdoor unit. If the wind is likely to blow as mentioned above, make sure to keep a sufficient service space and install a wind protective shield.

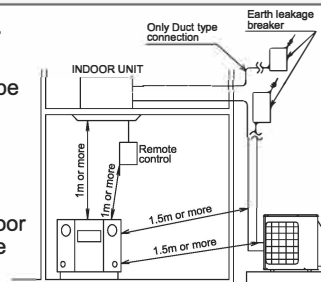

⚠ CAUTION

Inverter air conditioners may cause noise to occur in electrical appliances. As shown in the right drawing, select an installation site well away from radios, PCs, and stereos. Especially in the areas where the incoming signal strength is weak, keep the indoor remote controller 3 meter or more from electrical appliances. Put the power supply and transmission wiring in a metal piping and ground the metal piping.

2 SELECTING INSTALLATION SITE (2/2)

⚠ CAUTION

- 1) In a domestic environment this product may cause radio interference in which case the user may be required to take adequate measures.
- 2) When installing the unit in a place exposed to strong wind, pay special attention to the following. Strong winds of 5 m/sec or more blowing against the outdoor unit's air outlet causes short circuit (suction of discharge air) and this may have the following consequences:
 - Deterioration of the operational capacity.
 - Disruption of operation due to rise of high pressure.
 - When a strong wind blows continuously on the face of the unit, the fan can start rotating very fast until it breaks.
 Refer to the figures for installation of this unit in a place where the wind direction can be foreseen.
- 3) Following the installation place, it is expected that the influence of the strong wind is great.
 - The flat area which receives the adverse wind such as typhoon directly since there is no obstacles such as buildings and mountains. (Including coast line, shoreline of lake and mountain region.)
 - The installation place that no obstacles around the outdoor unit to prevent the adverse wind, for example, walls and buildings that are higher than the applicable outdoor unit, etc. Please take measures when installing especially on a rooftop.
 - Since the outdoor unit may fall down, attach the fixture for preventing overturning(option).

Turn the air discharge toward the building's wall fence or screen.

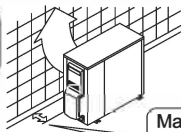

Make sure there is enough room to do the installation

STRONG WIND

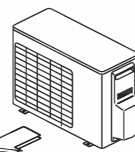

Set the outlet side at right angle to the direction of the wind.

AIR DISCHARGE



STRONG WIND

- 4) Prepare a water drainage channel around the foundation, to drain waste water from around the unit.
- 5) If the water drainage of the unit is not easy, please build up the unit on a foundation of concrete blocks, etc. (the height of the foundation should be maximum 150 mm).
- 6) If you install the unit on a frame, please install a waterproof plate within 150 mm of the underside of the unit in order to prevent the invasion of water from the lower direction.

3 INSTALLATION SERVICE SPACE (1/3)

- The installation servicing spaces shown in these drawings are based on the outdoor unit inlet area temperature of 35°C for COOLING operation.

If the planned inlet area temperature exceeds 35°C(DB), or if the heat load of all outdoor units is increased significantly and exceeds the maximum operating capacity, secure a larger space than that indicated by the inlet dimensions in these drawings.

- For installation, consider both pedestrian and air flow paths and choose a suitable pattern from these drawings to match the space available field. (If the number of units to be installed exceeds the patterns in these drawings, consider there is no short-circuits.)
- Regarding the front space, position the units with consideration to the space required for the refrigerant piping work. (Consult your dealer if the work conditions do not match those in the drawings.)
- Secure appropriate space when using a side piping outlet.

STAND-ALONE INSTALLATION

No Obstacle above

- 1) Obstacle on the suction side only

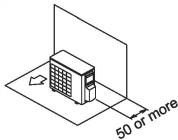

- To secure service space, more than 250 mm of each products at right side in needed.

(Units: mm)

- 2) Obstacle on both sides and suction side, too

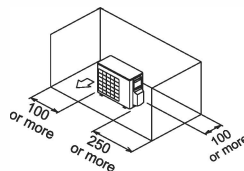

- 3) Obstacle on the discharge side only

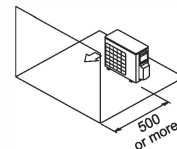

Obstacle above, too

- 1) Obstacle on the suction side, too

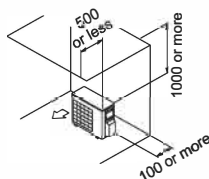

- 2) Obstacle on both sides and suction side, too

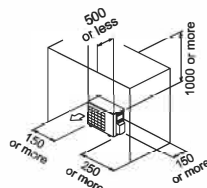

- 3) Obstacle on the discharge side only, too

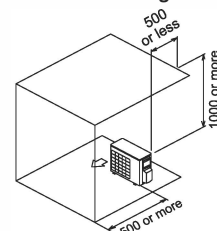

3 INSTALLATION SERVICE SPACE (2/3)

When there are obstacles on both suction and discharge sides

- To secure service space, (Units: mm)
more than 250 mm of each products at right side is needed.

Pattern 1) When the obstacles on the discharge side is higher than the unit

- 1) No obstacle above (There is no limit for the height of obstructions on the suction side.)
- 2) Obstacle above, too
The relations between H, A and L are as follows.

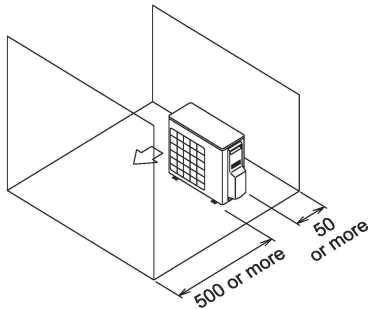

	L	A
$L \leq H$	$L \leq 0.5H$	750 or more
	$0.5H < L \leq H$	1000 or more
$L > H$	Set the stand as: $L \leq H$	

- ※ - Close the bottom of the stand to prevent the discharged air from being bypassed.
- The limitation of facilities connection is until 2 unit only.
- In case of more than dimension in (), It is no need to establish the stand although $L > H$

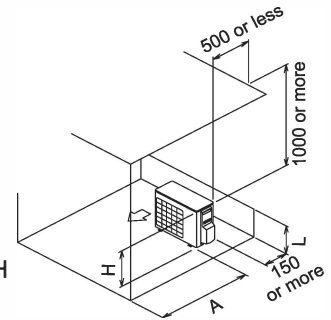

Pattern 2) When the obstacle on the discharge side is lower than the unit

- 1) No obstacle above (There is no limit for the height of obstructions on the suction side.)
- 2) Obstacle above, too
The relations between H, A and L are as follows.

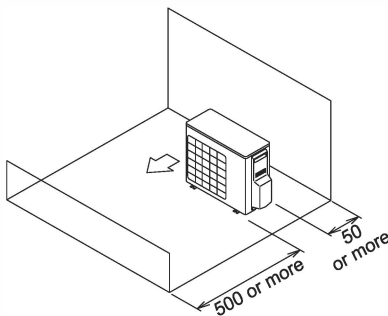

	L	A
$L \leq H$	$L \leq 0.5H$	50 or more
	$0.5H < L \leq H$	100 or more
$L > H$	Set the stand as: $L \leq H$	

- ※ - Close the bottom of the stand to prevent the discharged air from being bypassed.
- The limitation of facilities connection is until 2 unit only.
- In case of more than dimension in (), It is no need to establish the stand although $L > H$

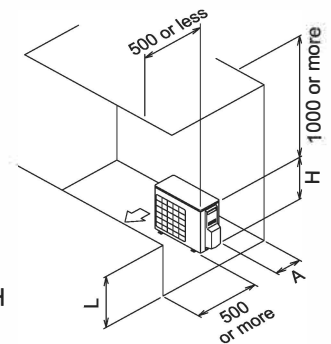

SERIES INSTALLATION (2 OR MORE)

- ※ Inside extraction, please provide the space of piping. (Units: mm)
- To secure service space, more than 250 mm of each products at right side is needed.

No obstacle above

- 1) Obstacle on the suction side and both sides

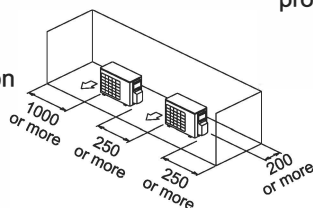

- 2) Obstacle on the discharge side only

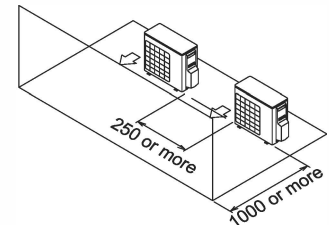

Obstacle above, too

- 1) Obstacle on the discharge side

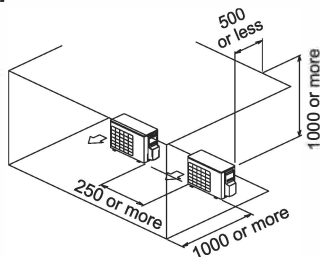

- 2) Obstacle on the suction side and both sides

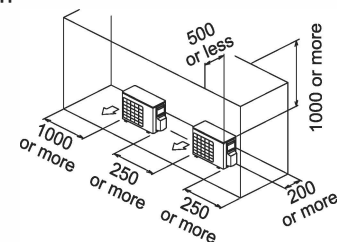

3 INSTALLATION SERVICE SPACE (3/3)

When there are obstacles on both suction and discharge sides

- To secure service space, more than 250 mm of each products at right side is needed.

Pattern 1 When the obstacles on the discharge side is higher than the side unit

1) No obstacle above (There is no limit for the height of obstructions on the suction side.)

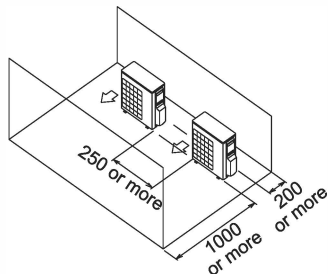

2) Obstacle above, too

The relations between H, A and L are as follows.

	L	A
$L \leq H$	$L \leq 0.5H$	1000 or more
	$0.5H < L \leq H$	1250 or more
$L > H$	Set the stand as: $L \leq H$	

- Close the bottom of the stand to prevent the discharged air from being bypassed.
- The limitation of facilities connection is until 2 unit only.
- In case of more than dimension in (), It is no need to establish the stand although $L > H$

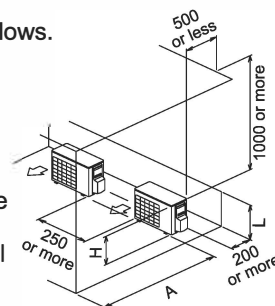

Pattern 2 When the obstacle on the discharge side is lower than the unit

1) No obstacle above (There is no limit for the height of obstructions on the suction side.)

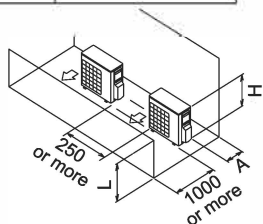

2) Obstacle above, too

(Units: mm)

The relations between H, A and L are as follows. The relations between H, A and L are as follows.

L	A
$L \leq 0.5H$	150 or more
$0.5H < L \leq H$	200 or more

	L	A
$L \leq H$	$L \leq 0.5H$	150 or more
	$0.5H < L \leq H$	200 or more
$L > H$	Set the stand as: $L \leq H$	

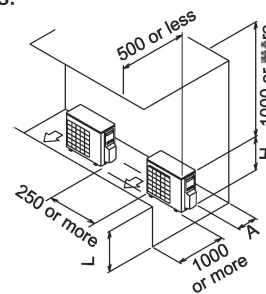

- Close the bottom of the stand to prevent the discharged air from being bypassed.
- The limitation of facilities connection is until 2 unit only.
- In case of more than dimension in (), It is no need to establish the stand although $L > H$

DOUBLE-DECKER INSTALLATION

(Units: mm)

- Do not stack more than two unit.
- The drain piping construction size of upper side outdoor unit is needed about 100 mm.
- In side extraction, please provide the space of piping.

1) Obstacle on the discharge side

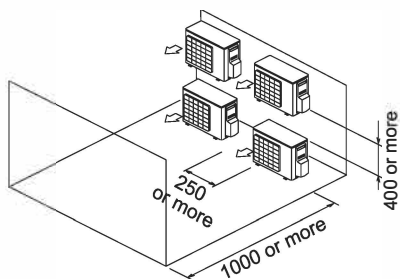

2) Obstacle on the suction side

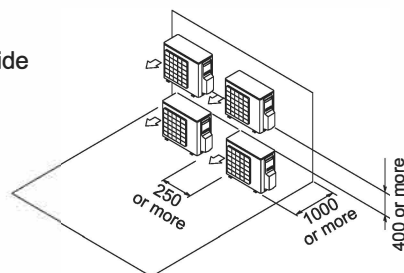

MULTIPLE ROWS OF SERIES INSTALLATION (ON THE ROOFTOP, ETC.)

1) One row of stand-alone installation

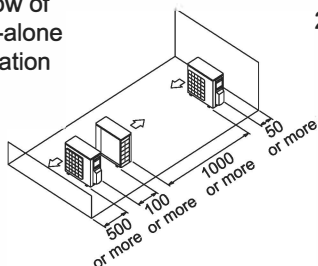

2) Rows of series installation (2 or more)

The relations between H, A and L are as follows.

	L	A
$L \leq H$	$L \leq 0.5H$	150 or more
	$0.5H < L \leq H$	200 or more
$L > H$	Can not be installed	

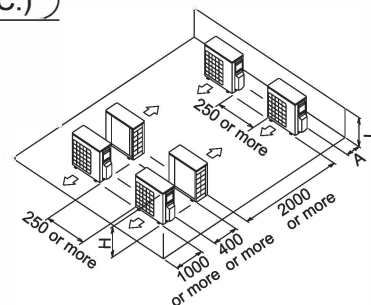

4 PRECAUTIONS ON INSTALLATION

- Check the strength and level of the installation ground so that the unit will not cause any operating vibration or noise after installed.
- In accordance with the foundation drawing in Fig. 1, fix the unit securely by means of the foundation bolts. (Prepare 4 sets of M12 foundation bolts, nuts and washers each which are available on the market.)
- It is best to screw in the foundation bolts until their length are 20 mm from the foundation surface.
- Fix the outdoor unit to the foundation bolts using nuts with resin washers. (See the left-hand of Fig. 1 drawing)
If the coating on the fastening area is stripped off, the nuts rust easily.

<Drain pipe disposal>

- If drain pipe disposal from the outdoor unit causes trouble, (for example, if the drain water may splash on people) provide the drain piping by using of the drain plug (optional).
- Then, coat the area around the bored holes with rust preventive coating to cover the metal exposure.
- Make sure the drain works properly.

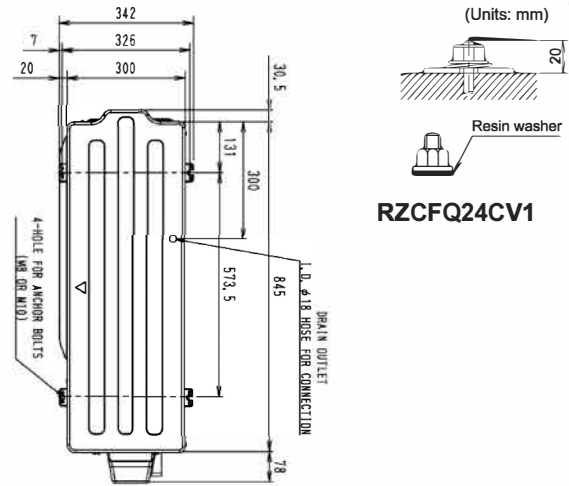

Fig : 1 BOTTOM VIEW

5 REFRIGERANT PIPING WORK (1/4)

CAUTION

To plumbing person

- Important information regarding the refrigerant used. This product contains fluorinated greenhouse gases covered by the Kyoto Protocol. Do not vent gases into the atmosphere.
GWP (global warming potential) of R32 refrigerant type = 675.
- Use R32 as additional for charging.
- Do not use flux when brazing refrigerant piping.
Use phosphor copper brazing filler metal (BCuP-2:JIS Z 3264/B-Cu93P-710/795:ISO 3677) that does not require flux.
(If chlorinated flux is used, the piping will be corroded and, in addition if fluorine is contained, the refrigerant oil will be deteriorated and the refrigerant circuit will be affected badly.)
- After chapter 7 CHARGING REFRIGERANT is completed, be sure to open the stop valves before performing 9 LOCAL SETUP.
(Operating the unit with the valve shut will break the compressor.)

«Precaution when reuse existed refrigerant pipe»

- Please keep below points in order to reuse existed pipe, failure may caused if have a fault.
- Below are pipes shall always make new construction, do not reuse piping.
 - When removed from indoor unit or outdoor unit for a long time.
(Moisture entry to internal pipe, wastes entry can be occurred.)
 - When copper tube is corroded.
 - When pipe thickness is insufficient (refer to 5-4 REFRIGERANT PIPE SIZE AND ALLOWABLE PIPE LENGTH)
 - Do not reuse flare for refrigerant leak protection, please make flare processing.
 - Do not reuse flare nut, please use flare nut in product accessories.
 - Make sure to do refrigerant leak check in case there is brazing area while perform field piping.
 - If insulation is deteriorate, make sure to exchange to new one.

5-1 INSTALLATION TOOLS

Be sure to use the dedicated tools to ensure sufficient pressure resistance and prevent the entry of any impurities.

Manifold gauge	To ensure sufficient pressure resistance and prevent the entry of any impurities (mineral oils such as Suniso oil and liquids), use the R410A or R32 dedicated item (the screw specifications for R410A or R32 differ).
Charging hose	
Vacuum pump	Be extremely careful not to flow the pump oil backward to inside the piping when the pump is stopped. Use a pump which enables vacuuming to -0.1 MPa(-755mmHg) of the gauge pressure.

5-2 SELECTION OF PIPING MATERIAL

- Use the piping whose inside and outside are clean and with no harmful substances for use such as sulphur, oxide, dust, dust from cutting, grease, or liquid (contamination) is attached.
- For the refrigerant piping, use the following material.
Material: Deoxidised phosphorous seamless copper piping
Temper grade: Use piping with temper grade in function of piping diameter as listed in the table on section 5-4 REFRIGERANT PIPE SIZE AND ALLOWABLE PIPE LENGTH
- Size: Decide based on section 5-4 REFRIGERANT PIPE SIZE AND ALLOWABLE PIPE LENGTH
- Thickness: Comply with applicable legislation. The minimal piping thickness for R32 piping must be in accordance with the table on section 5-4 REFRIGERANT PIPE SIZE AND ALLOWABLE PIPE LENGTH
- Be sure to perform piping work using measurements within the maximum allowable length and height difference described on section 5-4 REFRIGERANT PIPE SIZE AND ALLOWABLE PIPE LENGTH

5 REFRIGERANT PIPING WORK (2/4)

<Please refer to installation manual of indoor unit about indoor unit's refrigerant piping>

5-3 CARE OF PIPE

- Prevent contamination or moisture from getting into the piping.
- Pay special attention when running the copper piping through the through-hole or when leading the edge of the piping outside the room.
- Refrigerant piping must be protected from physical damage. Install a plastic cover or equivalent.

PLACE	INSTALLATION PERIOD	PROTECTION METHOD	PLACE	INSTALLATION PERIOD	PROTECTION METHOD
OUTDOOR	More than a month	Pinch the pipe	INDOOR	Unquestioned	Pinch or tape pipe
	Less than a month	Pinch or tape pipe			

5-4 REFRIGERANT PIPE SIZE AND ALLOWABLE PIPE LENGTH

- One way maximum allowable piping length means the maximum length of liquid side piping or gas side piping.
- Equivalent length is the pressure loss due to L joints, traps, and so on along the refrigerant piping converted to a straight piping length of the same size and added to the overall value.
Please see the Engineering Data for calculation of equivalent length.
- Please give the vertical interval between the indoor and outdoor as 20m or less.

CAUTION

This unit is chargeless specification. Due to chargeless length and allowable piping length will be different depend on field pipe size.

Piping bend radius

(Units : mm)

Piping diameter	Pipe thickness (material)	Bend radius
Ø 6.35mm	0.7mm (C1220T-O, Type O)	30mm or more
Ø 12.7mm	0.9mm (C1220T-O, Type O)	50mm or more

Refrigerant pipe size and chargeless length

Outdoor unit type	Liquid pipe size (type)	Chargeless length
RZCFQ24CV1	Ø 6.35mm x t0.7mm (type O)	10m

⚠ WARNING

- When flared joints are reused in indoors, the flared part shall be re-fabricated.

⚠ CAUTION

- Use dedicated piping cutters and flaring tools for R410A or R32.
- When making a flare connection, apply ether or ester oil only to the flare inner surface.
- Use only the flare nuts attached to the unit. If other flare nuts are used, it may cause refrigerant leakage.
- To prevent contamination, dust or moisture from getting into the piping, take measures such as pinching or taping the piping.

5-5 CONSTRUCTION OF REFRIGERANT PIPING

- Field pipes can be installed in Back - side connection. <Fig.2>
- Do not allow any substances other than the specified refrigerant such as air to mix into the refrigerant circuit.

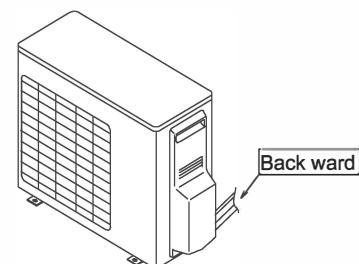

<Fig. 2>

5 REFRIGERANT PIPING WORK (3/4)

<Please refer to installation manual of indoor unit about indoor unit's refrigerant piping>

PREVENTING FOREIGN OBJECTS FROM ENTERING

- Plug the pipe through-holes with putty or insulating material (field supply) to cover all gaps, as shown in the figure.
- Insects or small animals entering the outdoor unit may cause a short circuit in the electrical box.

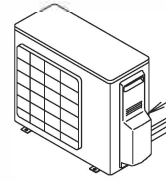

Putty or insulation material (Field supply)
Refrigerant piping must be protected from physical damage. Install a plastic cover or equivalent.

CAUTIONS FOR HANDLING STOP VALVE

DO NOT OPEN THE STOP VALVE UNTIL **7 CHARGING REFRIGERANT** FINISHED.

- The stop valves for indoor-outdoor connecting piping are closed at shipment from the factory. The names of parts are shown in figure on the right.
- Since the side boards may be deformed if only a torque wrench is used when loosening or tightening flare nuts, always lock the stop valve with a wrenches and then use a torque wrench.

When tightening the flare of the stop valves, make sure to tighten by the rated torque. The rated torque is shown on **(CAUTION FOR FLARE CONNECTION)** (Following)

DO NOT APPLY FORCE ON THE VALVE CAP, THIS MAY RESULT IN A REFRIGERANT LEAK.

- For cooling operation under low ambient temperature or any other operation under low pressure, apply silicon pad or similar to prevent freezing of the gas stop valve flare nut (see figure). Freezing of the flare nut may cause refrigerant leak.

How to operate the stop valve

Use hexagonal wrenches 5mm.

Opening the valve 1. Place the hex wrench on the valve bar and turn counter-clockwise.
2. Stop when the valve bar no longer turns. (It is now open.)

Closing the valve 1. Place the hex wrench on the valve bar and turn clockwise.
2. Stop when the valve bar no longer turns. (It is now close.)

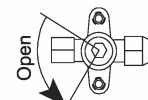
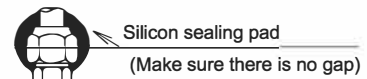
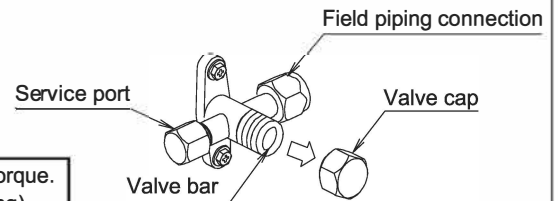

<Liquid side>

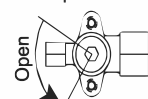

<Gas side>

CAUTIONS FOR HANDLING VALVE CAP

- A seal is attached to the point indicated by the arrow. Take care not to damage it.
- Be sure to tighten the valve cap securely after operating the valves.

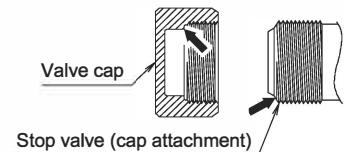

	Valve size (mm)	Tightening torque(N·m)		Valve size (mm)	Tightening torque(N·m)
Liquid side	∅ 6.35	15.7 ±1.5	Gas side	∅ 12.7	54.9 ±5.4

CAUTIONS FOR HANDLING SERVICE PORT

- Always use a flexible charge hose with a push-rod and valve to enable recovery of remaining refrigerant in the charge hose.
- After the work, tighten the valve cap in place.
- Tightening torque: **12.7 ± 1.2 N·m**



Do not use a charging hose of which pressing stick is slipped out from the center. (It may cause refrigerant leakage due to deformation to the valve stem of the service port)

PRECAUTIONS FOR CONNECTING PIPING

- Take caution so that the refrigerant piping between the outdoor and indoor may not touch and sound proof cover and the plate as shown figure.
- If installing the outdoor unit higher than the indoor unit, caulk the space around insulation and tubes because condensation on the stop valves can seep through to the indoor unit side.

PRECAUTIONS REGARDING INSULATION

Enhance the insulation of the refrigerant piping according to the installation conditions. If this is not done, condensation may form on the surface of the insulation. Please refer to the target values shown below.

- When the temperature and humidity conditions are 30°C and RH 75% or more: thickness of the insulation is 15 mm or more.
- When the temperature and humidity conditions are 30°C and RH 80% or more: thickness of the insulation is 20 mm or more.
- Be sure to insulate the liquid and gas sides interunit piping.

It may become the cause of refrigerant leakage if it is not insulated. (Be sure to use insulating material which can resistant.)

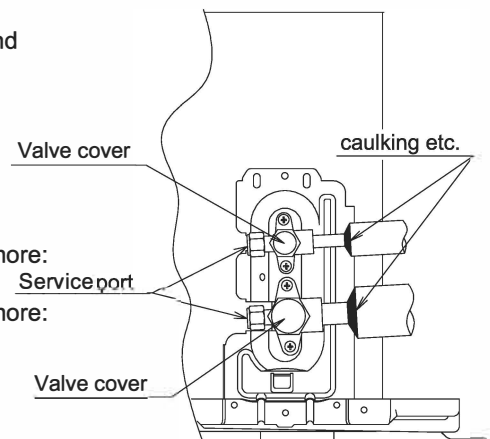

Insulation of interunit piping must be carried out up to the connection inside the casing. If the piping is exposed to the atmosphere, it may cause sweating or burn due to touching the piping, electric shocks or a fire due to the wiring touching the piping.

5 REFRIGERANT PIPING WORK (4/4)

CAUTION FOR FLARE CONNECTION

- Please be sure to remove a flare nut with a two-dish spanner, and to bind after connection of piping using a spanner and a torque wrench.
- Refer to the following table for a flare part processing size.
- When connecting the flare nut, apply refrigerating machine oil to the flare (inside) and at first screw the nut 3 or 4 turns by hand. Coat here with ether or ester oil.
- Refer to the table for the dimensions for processing flares and for the tightening torques. (Too much tightening will end up in splitting of the flare.)
- After completing the installation, carry out a gas leak inspection of the piping connections with nitrogen and such.

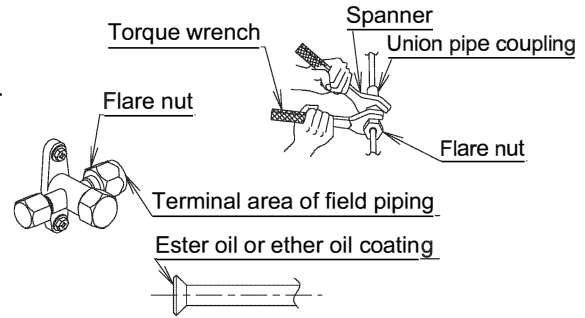

PIPING SIZE (mm)	TIGHTENING TORQUE	A DIMENSIONS FOR PROCESSING FLARES (mm)	FLARE SHAPE
Ø6.4	15.7 ± 1.5 N·m	8.9 ± 0.2	
Ø9.5	36.3 ± 3.6 N·m	13.0 ± 0.2	
Ø12.7	54.9 ± 5.4 N·m	16.4 ± 0.2	
Ø15.9	68.6 ± 6.8 N·m	19.5 ± 0.2	
Ø19.1	108.0 ± 10.8 N·m	23.8 ± 0.2	

- If a torque wrench is not available, be aware that the tightening torque may increase suddenly. Do not tighten nuts any further than to the angle as listed.
- When work is completed, be sure to check that there is no gas leakage.
 - ① A flare nut is bound tight with a spanner to the position whose torque with a bundle increases suddenly.
 - ② Only the angle of a right table is further bound tight from the position.

PIPING SIZE (mm)	FURTHER TIGHTENING ANGLE	RECOMMENDED ARM LENGTH OF TOOL
Ø6.4	60 to 90 degrees	About 150 mm
Ø9.5	60 to 90 degrees	About 200 mm
Ø12.7	30 to 60 degrees	About 250 mm
Ø15.9	30 to 60 degrees	About 300 mm
Ø19.1	20 to 35 degrees	About 450 mm

PRECAUTIONS WHEN BRAZING THE REFRIGERANT PIPINGS

<Do not reuse joint which have been used once already>

- When brazing the refrigerant piping, carry out brazing work (NOTE 2) after substituting nitrogen for air (flow nitrogen into the piping and substitute nitrogen for air (NOTE 1) (see the drawing below)).

NOTES

1. The proper pressure for having nitrogen flow through the piping is approximately 0.02MPa, a pressure that makes one feel like breeze and can be obtained through a pressure reducing valve.
2. Do not use flux when brazing refrigerant piping. Use phosphor copper brazing filler metal (BCuP-2: JIS Z 3264/B-Cu93P-710/795:ISO 3677) that does not require flux. (If chlorinated flux is used, the piping will be corroded and, in addition if fluorine is contained, the refrigerant oil will be deteriorated and the refrigerant circuit will be affected badly.)

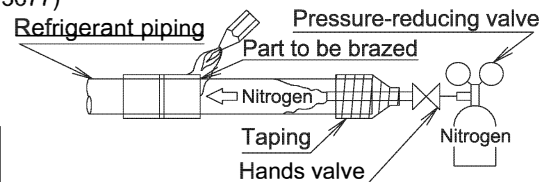

Prohibited

Do not use anti-oxidants when brazing the piping joints. (Residue can clog pipes and break equipment.)

6 AIRTIGHTNESS TEST AND AIR-PURGE

AIRTIGHTNESS TEST

- Perform a refrigerant leakage check using nitrogen gas (airtightness test) with the outdoor unit stop valve close, to make sure there are no leakage.
- For the airtightness test, raise the pressure to the design pressure in the high pressure section (4.17 MPa) For the airtightness test, the unit passes the test if the pressure in the high pressure section does not drop for 24 hours after increasing to the design pressure. A correction is required since the pressure decreases approx. 0.01Mpa when the ambient temperature of 1°C decreases.
- If the pressure drop is confirmed, perform the airtightness test again after checking and modifying the leakage points.

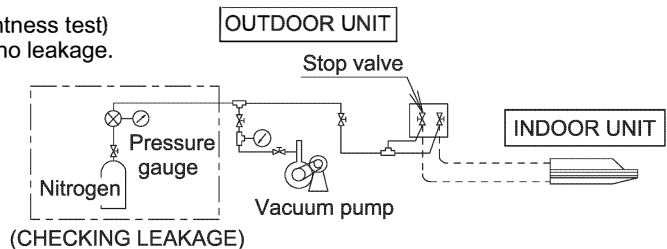

AIR-PURGE

- Evacuate by the vacuum pump for more than 2 hours until the internal pressure decreases below -0.1MP.
- After that, leave it with -0.1MPa or less for more than one hour and confirm that the value of vacuum gauges does not increase.
- If the value of vacuum gauge increases, there is moisture inside the refrigerant piping or there are leakage points. Perform evacuation again after checking and improving the leakage points.

NOTE

After doing an air-purge with a vacuum pump, the refrigerant pressure may not rise even if the stop valves are opened. This is because the refrigerant piping path is closed off by the outdoor unit electronic expansion valve, etc. There are no problems if the outdoor unit is running.

7 CHARGING REFRIGERANT (1/2)

◁ Be sure to use R32 as refrigerant. ▷

ADDITIONAL REFRIGERANT CHARGING

This model is chargeless type, so it is not necessary to charge additionally if pipe does not exceed the maximum allowable length without additional charge.

Please refer to the following table about the maximum allowable length without additional charge.

Liquid piping size	Length for which additional charging is not required
Ø 6.35mm x t0.7mm	10m

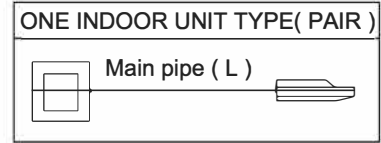

When piping length exceeds its of a top table,

or only when you perform recharging, Please be correctly charged according to the following.

For future servicing, please describe the amount of additional refrigerant charging, or the amount of recharging in the collective label in accessory set or back side of right side plate.

• In case of additional refrigerant charging

Please select the amount of additional refrigerant which suited piping length from the following table, and add it from the service port of liquid stop valve.

Outdoor units type	Liquid piping size	Length for which additional charging is not required	Length of piping exceeding the length for which additional charging is not required, R32 additional amount (kg)
			10m or less
RZCFQ24CV1	Ø 6.35mm x t0.7mm	10m	0.020

• Total refrigerant charging (When recharging due to exchange compressor, etc.)

Please charge refrigerant base on pipe length mentioned on the following table.

Outdoor units type	Liquid piping size	Piping length, R32 complete additional amount (kg)		
		5m~10m	10m or less	>10m and <30m
RZCFQ24CV1	Ø 6.35mm x t0.7mm	1.08	1.08	0.020 kg/m

When recharging refrigerant, follow the procedure below.

- ① In case of recharge refrigerant (cause of refrigerant leak) please follow suggestion below (reference detail from service guide)
 - In case of outdoor PCB (A1P) set refrigerant recovery mode at ON please press switch (BS1 for RZCFQ18CV1) for 5 second.
- ② Shut down the power at least 1 minute after setting process (1) is performed.
 - If the power is turned on before the process (3) - (6) are completed, the refrigerant recovery mode is turned off and the refrigerant cannot be recovered or charged normally. If the power is turned on by necessary, turn on Refrigerant recovery mode again.
- ③ Recover the refrigerant from both the refrigerant recovery port and liquid stop valve service port (or gas stop valve service port) simultaneously until the pressure drops below 0.09MPa (gauge pressure: -0.011MPa) by using a refrigerant recovery machine.
- ④ Modify the leakage points.
- ⑤ Perform the airtightness test and air-purge accordance with (6)AIRTIGHTNESS TEST AND AIR-PURGE.
- ⑥ Charge the refrigerant from the service port of the liquid side stop valve when recharging refrigerant.

(Note) Do not turn on power during evacuation.
The motor may be damaged due to vacuum discharge.

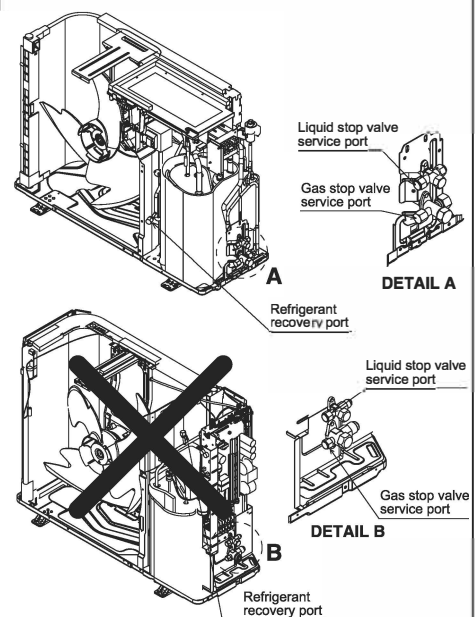

Be sure to write down the additional amount of refrigerant charged or the entire amount re-charged on the precaution plate on the rear of the front panel, as this information is needed in case of after-sales service.

7 CHARGING REFRIGERANT (2/2)

Precautions when adding R32 • Before charging, check whether the cylinder has a siphon attached or not.

Charging a cylinder with an attached siphon



Stand the cylinder upright at charging.
(There is a siphon piping inside, so that cylinder need not be upside-down to charge with liquid.)

Charging other cylinders



Stand the cylinder upside-down and charge.
(Turn the cylinder upside-down at charging.)

- To prevent entry of any impurities and ensure sufficient pressure resistance, always use the special tools dedicated for R410A or R32.
- The refrigerant should be charged from the service port of the liquid side stop valve.

WARNING

To persons incharge of piping work

- Please be sure to open a stop valve after a refrigerant charging end (if it operates shut, a compressor will break down).
- After complete charging of refrigerant carry out refrigerant leak check and heat insulation work.
- Please do not emit a refrigerant into the atmosphere indiscriminately.

8 ELECTRICAL WIRING WORK (1/3)

WARNING

- Install the earth leakage circuit breaker. (A duty of installation of a earth leakage circuit breaker is imposed for an electric shock and fire accident prevention.
The inverter is provided in the air conditioner. In order to prevent malfunction of the earth leakage breaker itself, use a breaker resistant to higher harmonics).
- Electrical wiring must be carried out by qualified personnel.
- Before obtaining access to terminal devices, all supply circuits must be interrupted.

CAUTION

To the electrician

- Make sure to install a current balance type earth leakage breaker coping with high harmonics.
(This unit is equipped with an inverter device. Use an earth leakage breaker coping with high harmonics to prevent wrong actuation.)
- Do not run the unit until the refrigerant charging is complete. (Operating the unit before the completion will break the compressor.)
- Do not remove the thermistors or sensors when the power supply and transmission wiring are connected.
(Operating the unit with the thermistors and sensors removed will break the compressor.)
- Make certain that all electric wiring work is carried out by qualified personnel according to the applicable legislation and this installation manual, using a separate circuit. Insufficient capacity of the power supply circuit or improper electrical construction may lead to electric shocks or a fire.
- An insufficient power supply capacity or improper electric work may lead to electric shocks or a fire.
- The wiring between the indoor unit and outdoor unit must be for 240V.
- For electric wiring work, refer to also the " WIRING DIAGRAM ".
- When doing the electrical wiring, always shut off the power source before working, and do not turn on the branch switch until all work is complete.
- Make sure to earth the air conditioner. Earthing resistance should be according to applicable legislation.
- Do not connect the earth wiring to gas or water piping, lightning conductor or telephone earth wiring.
 - Gas piping.....Ignition or explosion may occur if the gas leaks.
 - Water piping.....Hard vinyl tubes are not effective earths.
 - Lightning conductor or telephone earth wiring.....Electric potential may rise abnormally if struck by a lightning bolt.
- The earth is needed in order to reduce the noise generated by the unit's inverter and influence on other appliances and to release the charged electric charge on the outdoor unit surface by leaked current.
- Do not install a phase advance capacitor for improvement of power factor. Since this unit is mounted with an inverter device, the effect of power factor improvement not only cannot be expected, but also there is a risk of the capacitor getting abnormally overheated due to harmonics.
- Be sure to use earth leakage breaker dedicated for earth leakage protection in combination with the load break switch with fuse or breaker for wiring.
- In case of three-phase. Machine, electric wiring must be connected in normal phase connection.
- For wiring, use the designated power supply wiring and connect firmly, then secure to prevent external force being exerted on the terminal attachment (power supply wiring, transmission wiring, earth wiring).
- Left-over wiring should not be wrapped and stuffed into the outdoor unit.
- To prevent the power wiring from being damaged by the knock hole edges, put it in a wiring piping or use insulated bush, etc. to protect it.
- To prevent the wiring from coming in contact with piping (particularly the high-pressure piping), secure it with the included clamping material as shown page 32.
- When wiring, form the wiring so that the front plate does not float and make sure the front plate is securely fastened.
- Fix the power supply wiring, the earth wiring and the transmission wiring by clamps as shown in the figure.

8 ELECTRICAL WIRING WORK (2/3)

- As shown in the following figure, please fix power supply wiring, field wiring and ground wire by clamp material.

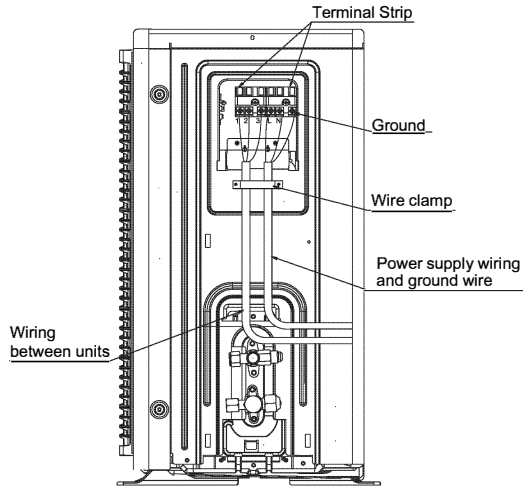

RZCFQ24CV1

- Carry out insulated processing of attaching an insulated sleeve. Power supply wiring, wiring between units and ground tying with clamp as shown below.

⚠ Do not connect power supply to terminal block of transmission wiring. All system may get damaged.

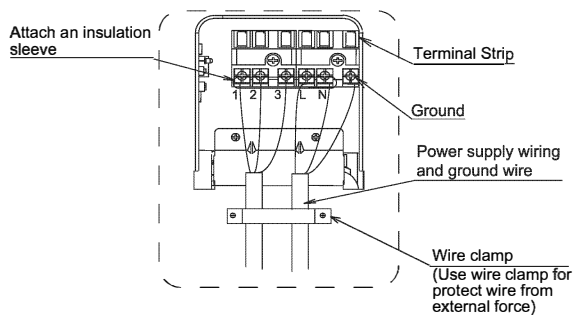

RZCFQ24CV1

Connection of wiring

Precautions on wiring

- Use a round crimp-style terminal for connection to the power supply terminal board. In case it cannot be used due to unavoidable reasons, be sure to observe the following instruction.
- Do not connect wires of different gauge to the same power supply terminal. (Looseness in the connection may cause overheating.)

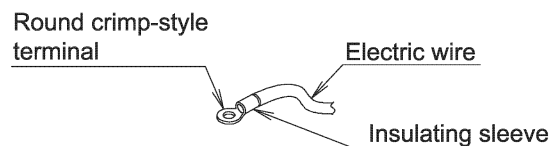

8 ELECTRICAL WIRING WORK (3/3)

When connecting wires of the same gauge, connect them according to the below figure.

Connect wires of the same gauge to both sides



Do not connect wires of different gauges



Do not connect wires of the same gauge to one side



- Never use the stranded wiring which is soldered.
(Slack in the electric wiring may cause abnormal heat.)
- Use the required wirings, connect them securely and fix these wirings so that external force may not apply to the terminals.
- Use a proper screw driver for tightening the terminal screws.
If an improper screw driver is used, it may damage the screw head and a proper tightening cannot be carried out.
- If a terminal is over tightened, it may be damaged. Refer to the table shown below for tightening torque of terminals.

Tightening torque (N•m)	
M4 (Wire between units terminal board)	1.50±0.30
M4 (Power supply terminal board)	1.50±0.30
M4 (Ground wire between units)	1.69±0.25
M5 (Ground wire between units)	3.55±0.50

Precautions on connecting terminal of grounding

- Ground wiring should be taken out from the cut out section of a cup washer.
(Otherwise, contact of ground wiring is inadequate and it is ineffective.)

Ring type crimp-style terminal

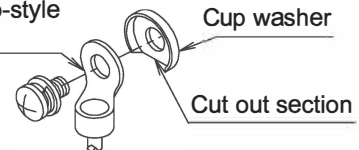

WIRING OF POWER SUPPLY AND THE UNITS

For details on the wiring of the indoor unit and wiring between units refer to the installation manual of the indoor unit.

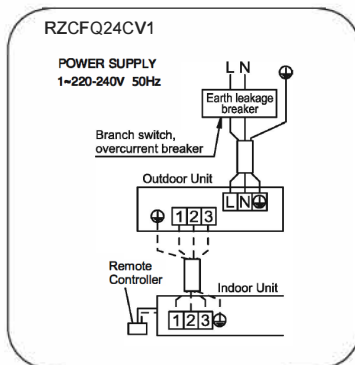

• SPECIFICATIONS OF STANDARD WIRING COMPONENTS

Outdoor Unit	Power supply			Wire type of wiring between the units
	Recommended field fuse	Wire type (*)	Size	
RZCFQ24CV1	20	H05VV-U3G	Wiring size and length must comply with local codes or [IEC 60335-1 (Table 11)]	H05VV-U4G2.5

(*) Only in protected piping, use H07RN-F when protected pipes are not used.

(Supply cords shall not be lighter than polychloroprene sheathed flexible cord (code designation 60245 IEC 57))

NOTES

1. Select and install the power supply wiring in accordance with [IEC 60335-1 (Table 11)] or local laws and regulations. The maximum current of the outdoor and indoor units are shown on each name plate.
2. When installing wiring in a location that can easily come in contact with people, be sure to install an earth leakage breaker coping with high harmonics to prevent electric shock.
3. Breaker type and capacity shall be selected in accordance with local laws and regulations.

CAUTION

TO PERSONS INCHARGE OF ELECTRICAL WIRING WORK

- Do not operate the unit until the refrigerant charging is completed. (Running it before the piping is ready will break the compressor.)

9 CHECK ITEMS BEFORE TEST OPERATION AND FIELD SETTINGS

PRE-RUN CHECKS

	ITEM TO CHECK	CHECK
Power supply Wiring	Is the wiring as mentioned on the wiring diagram? make sure no wiring has been forgotten and that there are no missing phases or reverse phases.	
	Does wiring between units put in and changed in continuation installation?	
	Is the unit properly grounded?	
	Are any of the wiring attachment screws loose?	
	Is the insulation resistance at least 1MΩ? • Use a 500V mega-tester when measuring insulation • ※ Do not use a mega-tester to low voltage circuit except 220-240V.	
	Is an earth leakage circuit breaker used as a current operated type which is compatible to the higher harmonic wave?	
	Does the earth leakage circuit breaker have appropriate rated current?	
Refrigerant piping	Is the size of the piping appropriate?	
	Is the insulation material for the piping attached securely? Are both the liquid and gas pipes insulated?	
	Are the stop valves for both the liquid side and the gas side open?	
	Did you write down the extra refrigerant and the refrigerant piping length?	
Indoor unit	Is the indoor unit fully installed? When the test run is started, the fan automatically begins turning.	

WARNING

- When a power supply is switched on, when you leave from the outdoor unit, be sure to close the cover plate. (It becomes the cause of an electric shock).

In field setting for an outdoor unit, make sure to shut down the power and check that there is no residual voltage before start installing. (It may cause an electric shock.)

THE METHOD OF LOW NIGHT NOISE SETTING USING THE REMOTE CONTROLLER

The functions of the "Low Night Noise Setting" outdoor unit can be set by using the remote controller. During installation, make the field settings according to the description below, after the service inspection and repair. Mistakes in the setting could cause malfunctions.

HOW TO MAKE THE FIELD SETTINGS

Make the field setting according to "How to make the field settings" which come with the remote controller. The settings are set by switching between "Mode No.", "FIRST CODE No.", and "SECOND CODE No."

CONTENT OF SETTINGS AND SETTING NUMBER

: Factory settings

Mode NO.	FIRST CODE NO.	Description	SECOND CODE NO.					
			01	02	03	04	05	
16 (26)	0	Night time low noise operation	<input checked="" type="checkbox"/>	Automatic Low noise activation				
	1	Automatic low noise start and stop time			22h00 06h00	<input checked="" type="checkbox"/> 22h00 <input checked="" type="checkbox"/> 08h00	20h00 08h00	
	2	High sensible cooling setting	<input checked="" type="checkbox"/>		Server room setting	Anti-Frozent + Server room setting (combine)		

See the service manual for details on the content of the settings.

NOTES

- Settings are done in a batch for the group. For this reason, when performing group control* using the remote controller from one unit to set individual outdoor units, set each unit separately (for each connected indoor unit no.) using the mode number in parentheses. Checking after changing settings can also only be done using the mode numbers in parentheses. (For group batch control, the display will always read "01" even though the settings have been changed.) Furthermore, when performing control with two remote controllers*, field settings using a remote controller can only be done using the main remote controller.

* For details on controlling the units using the remote controllers, see applicable service manual.

- Do not set any values not shown in the table above.

CAUTION

- For settings other than the above, refer to the caution label or the service manual.
- Low night noise operation and demand operation using an external command requires a demand adapter PC board (option). For more details, refer to the manual supplied with the adapter.

10 TEST OPERATION

WARNING

- Never perform a test operation with the discharge piping thermistor(R2T) and suction piping thermistor(R3T) removed, as this might break the compressor.
- If the technician must leave the outdoor unit for some reason, switch places with another installation technician or close the plates. (It may cause electric shocks.)

HOW TO TEST OPERATION

After the indoor and outdoor unit installation, be sure to perform the test operation in accordance with the following procedure.

1. Open the stop valve cover and check that the liquid and gas sides of the stop valves are open.
<Be sure to close the front plate before the operation (there is a risk of electric shock)>
Note: After doing an air-purge with a vacuum pump, the refrigerant pressure may not rise even if the stop valves are opened. This is because the refrigerant piping path is closed off by the outdoor unit electronic expansion valve, etc. There are no problems if the unit is run.
2. Attach the stop valve cover to the outdoor unit and turn the power on at least 6 hours before operating the outdoor unit to protect the compressor.
3. Set to COOLING operation with the remote controller.
4. Perform the test operation
 - When doing trial operation, it may take about 1 minute until the compressor begins to function, but this is not abnormal.
 - When using the system the first time after installation, even if heating operation is selected, cooling operation will take place for about 3 to 5 minutes.
Thereafter, it will change to heating operation, but this is not abnormal. (In this case, the remote controller display will continue to display "heating operation.") This is in order to detect if someone has forgotten to open the stop valve during trial operation.
 - If the outside air temperature is about 24 C or more, even if HEATING operation is set, the system may not operate, but this is not abnormal.
5. Operate normally.
6. Confirm function of the indoor and outdoor units according to the operation manual.

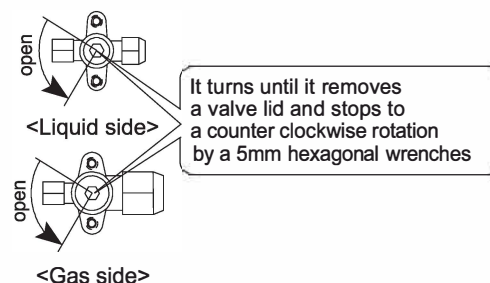

MALFUNCTION DIAGNOSIS

- At the time of a test run, when the following malfunction code is displayed on remote control, the fault of installation construction can be considered.

Malfunction code	Installation error	Remedial action
[E3] [E5] [U0] [L8]	A failure of a stop valve to open	"Open" operation of a stop valve
[E3] [E5] [L4] [L8]	Closing of an air passage	Removing closing thing from air passage
[U1]	Missing phase, negative phase	2 Phase of power supply 3 Phase (L1, L2, L3 Phase) are replaced
[U2]	Power supply unbalancing	Unbalanced dissolution
[U4] [UF]	Incorrect connection of field wiring	Correction of wiring
[UA]	Connection of incompatible indoor unit	Connect appropriate indoor unit (Refer to the catalogue)
NO INDICATION	Mistake wiring or not connect wiring of power supply, indoor, outdoor, field wiring between indoor unit	To correct wiring or connect correctly

- When malfunction codes other than the above are displayed on remote control, considering that the failure of between an indoor and an outdoor unit may have.
For the malfunction codes, please refer to the indoor unit's installation manual or outdoor service manual. (A malfunction code has what has a display according to the form of the interior of a room and an outdoor unit, and the thing which is not.)
- The followings can be considered causes when the breaker for power supply trips.
 - The capacity of a breaker for power supply is smaller than the required capacity of the leakage circuit breaker.
 - The leakage circuit breaker is not compatible to the higher harmonic wave.
- In case of already checking all equipment that not have any problem, but found air conditioner not cooling. Please re-check Motor operate valve coil not tighten or remove for 1st checking. If normally please re-confirm problem following service manual to solve problem.

CAUTION

To persons incharge of piping work and electric work

- Please check having attached the front board and the piping cover after a test run end when giving production over to customer.

11 CAUTION (RZCFQ24CV1)

THIS IS NECESSARY FOR AFTER SERVICE, SO PLEASE REQUEST CUSTOMER TO KEEP THIS MANUAL.

CAUTION (NEW REFRIGERANT (R32 SERIES))



Caution about electric shock when do service inspection

1. After intercept power supply, do not open outside panel for 10 minutes.
2. Follow manufacturing label on electric box cover, please take off outdoor fan motor connector to confirm voltage and body static electricity discharge.

General caution items when do service inspection

Caution to confirm compressor and fan motor running

Do not directly connect power input (3 Phase 50Hz) to compressor and fan motor. (If not connect to print board (PCB), compressor and fan motor will be burned out.)

Caution when recharge refrigerant

1. To prevent the mixing of impurities, pressure resistance and contamination mix, please use manifold gauge especially for R32.
2. Make sure to do Nitrogen blow if brazing when flare connection.
Apply ether oil or ester oil at inside flare only.
3. Do air tight test at 4.17MPa.
4. Do dry vacuum, make sure to charge refrigerant in liquid condition from liquid side service port. (Compressor will be broken if charge from gas side service port.)

Caution when use outdoor PCB

Make sure to touch earth terminal and earthed metal before touch pcb, to prevent electric shock

Caution when break down diagnosis from letter code in remote control

Please refer to service guide or outdoor unit installation manual.

Charging refrigerant

Charging the system with refrigerant

(For more information such as calculation method of additional refrigerant charge, additional charge method, refrigerant charge caution, refer to the installation manual and technical Guide.

- For refrigerant charge, be sure to charge from the service port of the liquid side stop valve in liquid states. (If you charge from the service port of the gas side stop valve, it may break the compressor.)
- Never charge other than the specified refrigerant. (It may cause fire and bursting.)

Table 1. Chargeless piping length

Liquid piping size	Pipe length which is not required additional charging
Ø 6.35mm x t0.7mm	10m

1. In case of additional refrigerant charging

Please add refrigerant amount according to the following table.

Outdoor	Liquid piping size	Pipe length which is not required additional charging	Piping length, R32 complete additional amount (kg)
RZCFQ24CV1	Ø 6.35mm x t0.7mm	10m	<10m and >30m 0.020 kg/m

2. Total refrigerant charging (Details please see service guide)

1. Please recover the refrigerant until becoming 0.09MPa (gauge pressure:-0.01MPa) or less by the refrigerant recovery machine from stop valve service port (liquid-gas side) at the same time.
2. Exchange service parts, modify leak point.
3. Perform airtightness test, air-purge.

Please refer installation manual of outdoor unit or service guide.

4. Charge refrigerant amount selected by table 2 from liquid stop valve service port.

Caution Do not turn on power during evacuation. The motor may be damaged due to vacuum discharge.

Table 2. Charge refrigerant amount (After a leak, etc...)

Outdoor	Liquid piping size	Piping length, R32 complete additional amount (kg)	
		5~10m	<10m and >30m
RZCFQ24CV1	Ø 6.35mm x t0.7mm	1.08	0.020 kg/m

• Making a record of the added refrigerant charge amount

Be sure to record the piping length and added refrigerant charge amount or refrigerant recharge amount with an oil-based or other indelible marker so the figures will not fade over time. This information is necessary for after service and maintenance.

Liquid piping size	Ø 6.35mm x t0.7mm
Refrigerant piping length	m
Additional refrigerant charging	kg
Recharge of refrigerant	kg

How to execute a pumping-down

(for example, when moving or reinstalling an indoor or outdoor unit)

The outdoor unit is equipped with a high pressure switch to protect the compressor.

Caution Never short circuit the high pressure switch during pump-down operation.

- It is not allowed to let the refrigerant out into air.
- The refrigerant should be recovered completely.
- Although pumping-down operation allows most of the refrigerant to be recovered in a short period of time, some refrigerant will remain inside the indoor unit and the refrigerant piping. Using a refrigerant recovery machine, recover remaining refrigerant from the stop valve service port until the pressure falls to 0.09MPa (gauge pressure:-0.011MPa) or less
- Be sure to execute the pumping-down before refrigerant piping and wiring is taking off.

For pumping-down operation

1. Please follow the [caution about electric shock when service inspection] which attached on Top panel (Caution: Do not take off the connector X106A)
2. To prevent electric shock, please protect power input terminal block by insulation sheet refer to below figure.
3. Turn on the power supply and carry out pumping-down operation according to the following procedure.

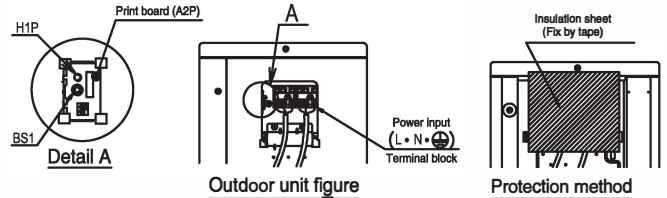

Caution To prevent electric shock when inspection, protect by use insulation sheet on power input terminal block and print board (A2P)

For pumping-down operation

- Do not remove the indoor unit until pump down operation finish. (It is dangerous when indoor fan automatically starts the operation.)

Perform pumping-down operation using the following procedure

Procedure	Precaution
1 Confirm that stop valves both on the liquid and gas sides are open	-
2 Push the pumping-down (BS1) on the PC board of the outdoor unit for 5 seconds.	Compressor and outdoor unit fan will start operation automatically. Indoor fan may automatically start running. Pay attention to this.
3 Close the stop valve on the liquid side securely about 2 minutes after the compressor started operation. Once the compressor operation stops after 2 to 5 minutes, close the stop valve on the gas side securely.	• Do never leave the outdoor unit unattended with opened front plate when power supply is on. • In case the stop valve on the liquid side is not securely closed during compressor operation, pumping-down operation cannot be executed
4 Turn off the power supply.	When you work alone, carry out after closing the front plate, After turning the power supply off, remove the insulation sheet.

- If after finishing pumping-down operation the outdoor unit does not operate, even when the remote controller switched on, the remote controller may or may not indicate "U4". But it is not a malfunction.

- To force of operation, turn off the main power supply and turn it on again. Make sure that stop valves both on liquid and gas sides are open and be sure to operate the unit in cooling operation during test run.

Liquid stop valve



Gas stop valve



Caution When installing and relocating, be sure to install the earth leakage breaker to protect from the electric shock disaster and fire due to leakage of electricity. For installing the earth leakage breaker, request to the qualified electrician.

How to confirm of running condition by LED

When the power supply turns "ON", you can check diagnosis of failure by service monitor (AP2) on the outdoor print board LED.

- LED light on
- LED flash
- LED light off
- Not relate with diagnosis

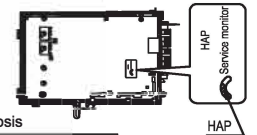

LED		(ITEM)
HAP (Green)	H1P (Red)	
•	•	Normal
•	—	Outdoor PCB defect (Note 1)
•	•	Power input abnormal or outdoor PCB defect (Note 2)
•	•	Protection device running (Note 3)

(NOTE 1) Power off for more than 5 seconds, power ON again, and confirm the diagnosis again.

(NOTE 2) Power off for more than 5 seconds, take OFF connection wiring (indoor transmission) and power ON again. If after 10 seconds, outdoor PCB shows [HAP] it means indoor PCB defected.

(NOTE 3) There is phase interruption.

(NOTE 4) Previous abnormal history will be continuing display until power OFF. After inspection, please power OFF.

Caution about break down diagnosis by remote control letter code.

Please refer to service guide or outdoor unit installation manual.

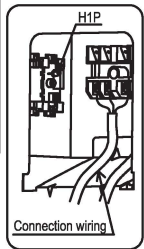

12 HOW TO RE-USE THE EXISTING PIPING

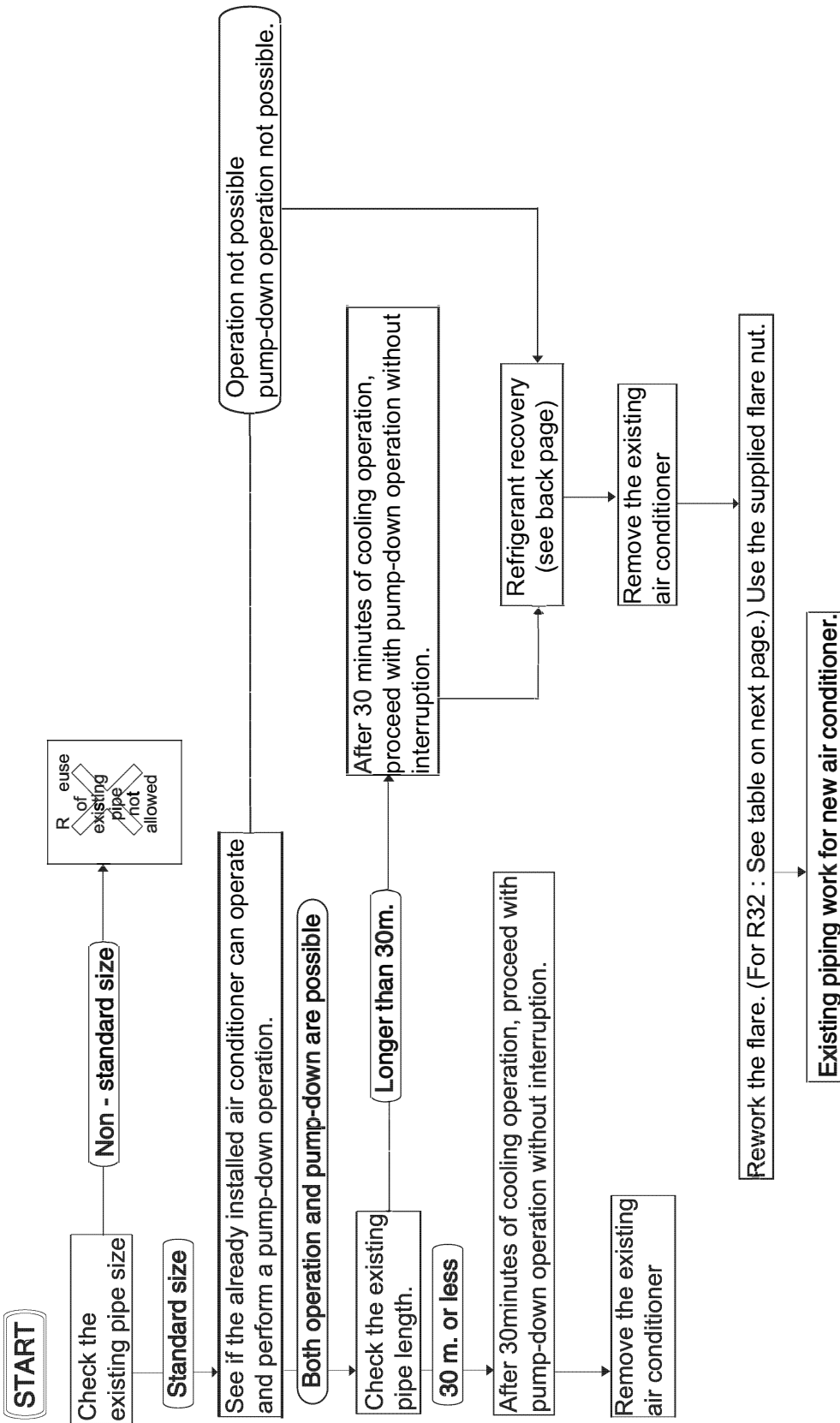

(Note)

1. Clean the pipe if refrigerant leakage and unit has not service port on gas-liquid stop valve.
2. If indoor unit equipped with EV valve, open that valve before recovery refrigerant.
3. **Maximum pipe length as per specified on next page.**

PRECAUTIONS ON REFRIGERANT PIPING

- Clean pipe if existing air conditioner is [gas, oil heat pump type].
- Clean pipe if used compressor oil in existing air conditioner is other than [SUNISO, MS, HAB, Barrel freeze, JOMO, Ethereal oil, Ester oil].
- Clean pipe if existing indoor and outdoor unit is disconnected.
- Change new pipe if refrigerant leakage or it should adding refrigerant.
- Change new heat insulation if existing part is peeling off.

13 REFRIGERANT RECOVERY

[Working procedure]

- 1. Recovery retaining oil in existing pipe Approx. 1 min**
Close gas stop valve (liquid stop valve: open) and recovery refrigerant from gas stop valve port.(Fig.1)
- 2. Recovery retaining oil in existing liquid pipe Approx. 1 min**
Recovery refrigerant from liquid stop valve port. (Fig.2)
- 3. Recovery refrigerant in outdoor unit Approx. 2-3 min**
Recovery refrigerant from outdoor unit refrigerant recovery port *1 .(Fig.3)
- 4. Recovery refrigerant in accordance with Fluorocarbons Recovery and Destructive Law**
If refrigerant recovery port *2 pressure become lower than gas stop valve port pressure, refrigerant will recover at the simultaneous from the gas stop valve port, open gas stop valve (Fig.3- 1) gradually to avoid from pressure rising rapidly. (Fig.3- 2)
NOTE 1 Can be omit this procedure if there has no refrigerant recovery port simultaneously if there has no refrigerant recovery port.

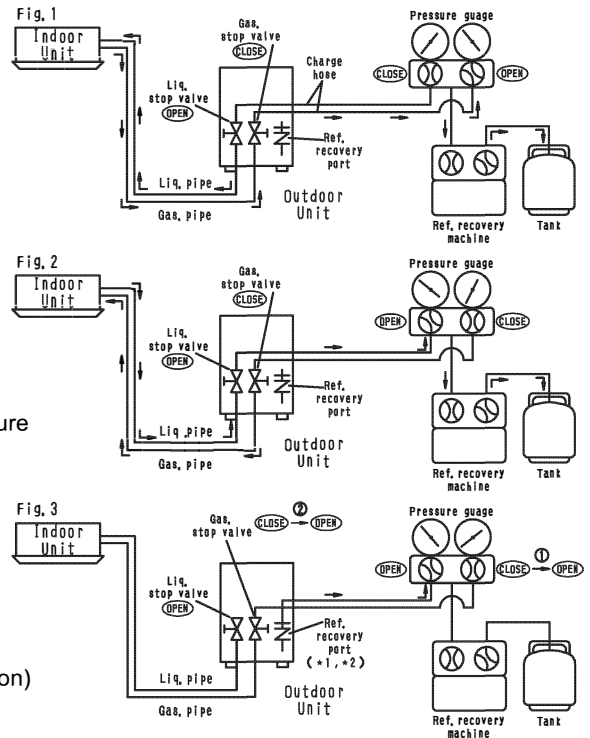

Retaining oil recovery amount improved approx. 5 times from regular refrigerant recovery method

(pipe length, height difference, pipe path etc. is difference by installation condition)

ABOUT FLARE PROCESSING

- Flare connection area of existed piping will cause processing deterioration, make sure to do newly re-processing.
- Flare processing [Unit: mm]

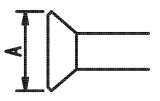

Piping diameter	A (+0,-0.2) For R32
Ø 6.35	9
Ø 12.7	16.2

- Please use flare nut which attached with product (Do not use existed flare nut)
- Flare nut [Unit: mm]



Piping diameter	B (+0,-0.6) For R32
Ø 6.35	17
Ø 12.7	22

REFRIGERANT PIPE SIZE TABLE

Outdoor Unit		Existing pipe size	6.35/12.7	Height difference	Design pressure (High pressure)
RZCFQ24CV1	6.35/12.7	Standard pipe length	7.5m	Max 20m	4.17 MPa
		Max. pipe length	30m		
		Chargeless pipe length	10m		

- Refer to the installation manual for details other than those mentioned above table such as additional refrigerant charge amount.
- Clean the existing piping if it length is exceed 30m.
- Clean the existing pipe if chargeless length is exceed limit of existing pipe pump down refrigerant recovery.

■ Standard pipe (R32)

Pipe size (mm)	Ø 6.35	Ø 12.7
Thickness (mm)	t0.7	t0.9

14 UNPACKING & PACKING OF THE OUTDOOR UNIT

14-1 UNIT UNPACKING

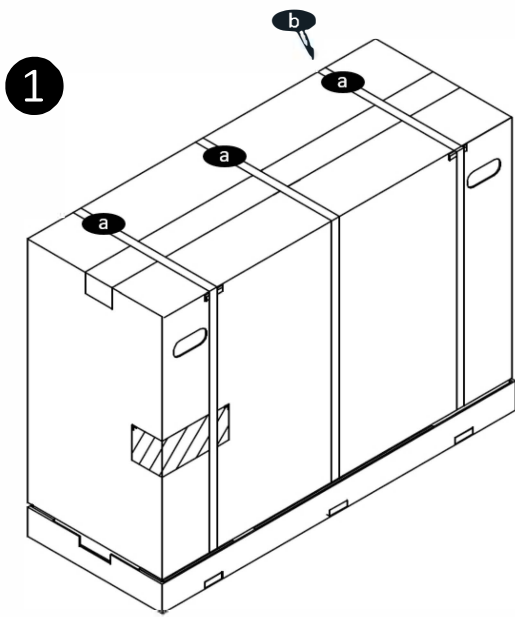

- Cut all the straps (a) from the unit using strap cutter(b) as shown in figure.

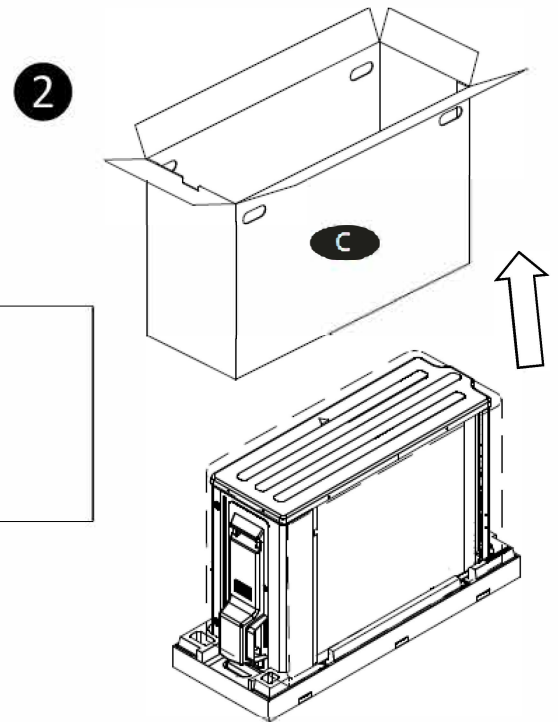

- Remove the cardboard box(c) from the unit after opening it and pulling it up as shown in figure.

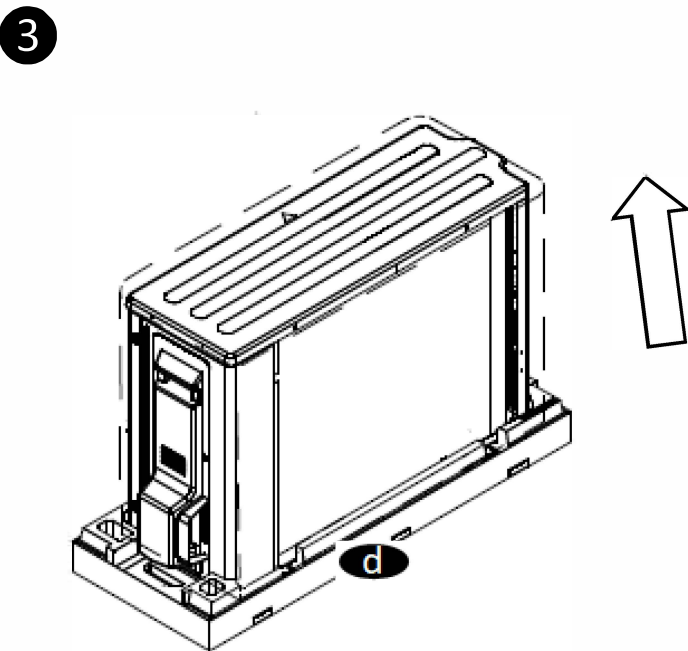

- Remove the bottom skid(d) with EPS by pulling the unit up, then remove the polythene product cover by pulling it up



14-2 UNIT PACKING

1

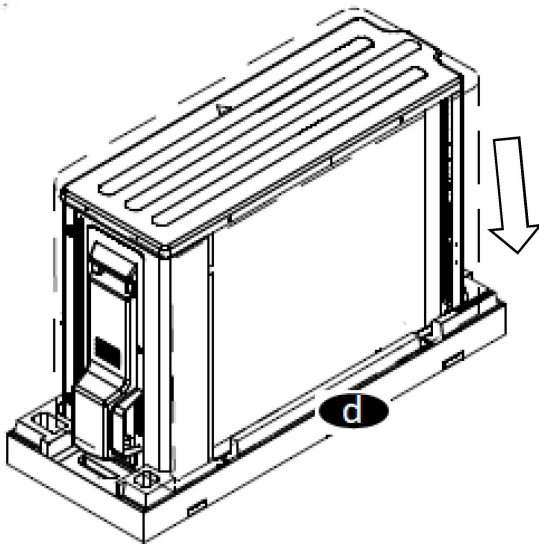

- a) Strap
- b) Strap Cutter
- c) Cardboard box
- d) Bottom Skid
- e) Portable strap fixing machine

- Cover the unit with polythene product cover, then pick the unit up and settle it down on the bottom skid(d) as shown in figure.

2

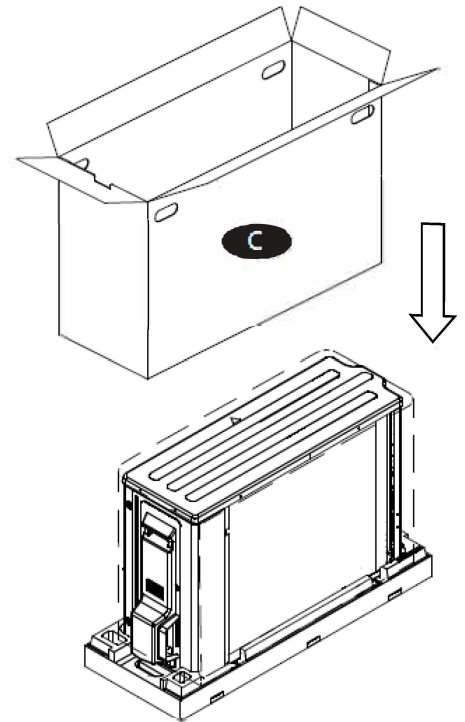

- Put the cardboard box (c) upon the unit as shown in figure.

3

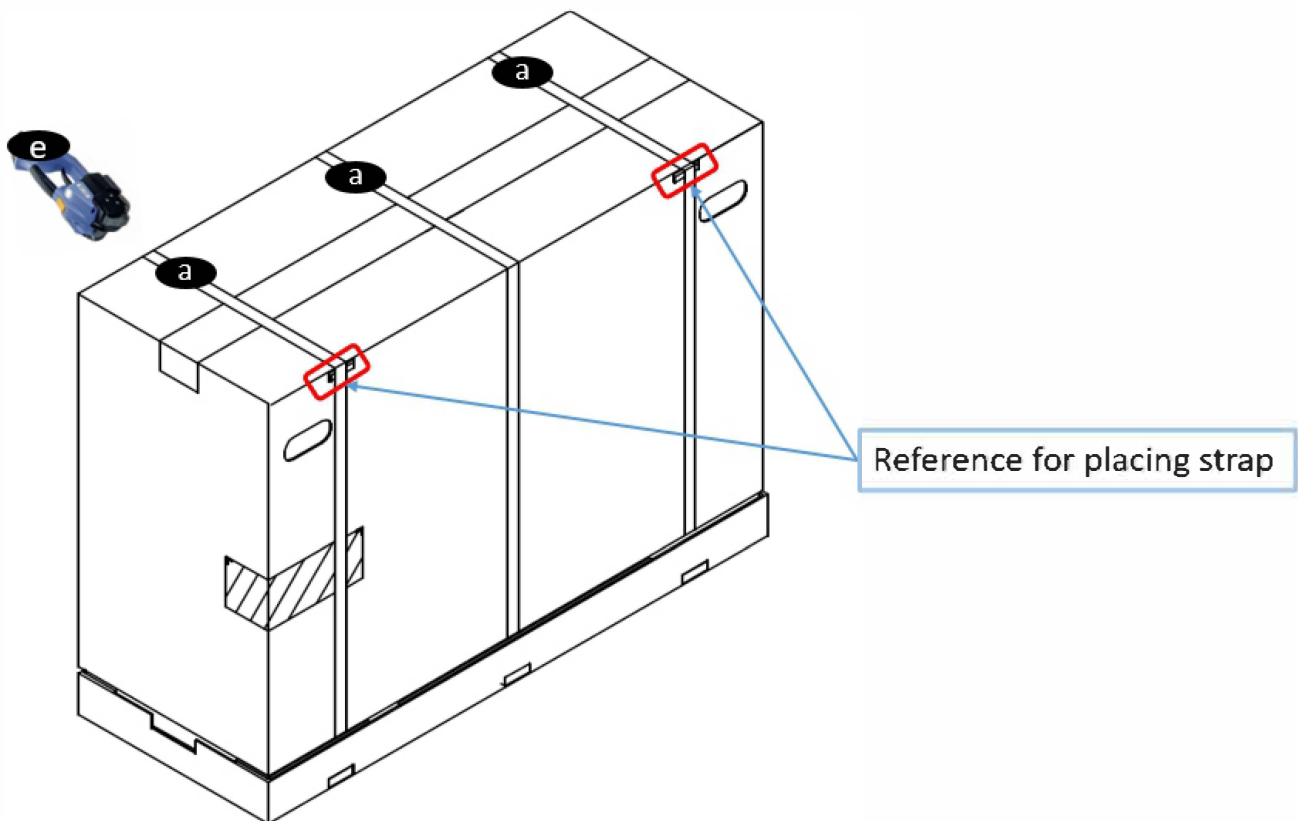

- Fix the straps (a) on the unit by using portable strap fixing machine as shown in figure.(Use marked reference for placing straps)

SPLIT SYSTEM**Air Conditioners**

MODEL

Ceiling mounted cassette type (Sensing and Non Sensing flow model)

INDOOR**OUTDOOR****FCFQ24CV1****RZCFQ24CV1****English**

CONTENTS

1. SAFETY PRECAUTIONS	55
2. WHAT TO DO BEFORE OPERATION	57
3. OPERATION RANGE	58
4. INSTALLATION SITE	58
5. OPERATION PROCEDURE	58
6. OPERATION CHARACTERISTICS	59
7. OPTIMUM OPERATION	60
8. MAINTENANCE (FOR SERVICE PERSONNEL)	61
9. NOT MALFUNCTION OF THE AIR CONDITIONER	63
10. TROUBLE SHOOTING	65

1. SAFETY PRECAUTIONS



Read the precautions in this manual carefully before operating the unit.



This appliance is filled with R32.

To gain full advantage of the air conditioner's functions and to avoid malfunction due to mishandling, we recommend that you read this instruction manual carefully before use. This air conditioner is classified under "appliances not accessible to the general public".

- **Read the precautions thoroughly to avoid misuse of the equipment.**
- **The precautions described herein are classified as WARNING and CAUTION. They both contain important information regarding safety. Be sure to observe all precautions without fail.**
- **There are two kinds of safety precaution and tips listed in the following.**

⚠ WARNINGFailure to follow these instructions properly may result in personal injury or loss of life.

⚠ CAUTIONFailure to observe these instructions properly may result in property damage or personal injury, which may be serious depending on the circumstances.

- **After reading, keep this manual in a convenient place so that you can refer to it whenever necessary. If the equipment is transferred to a new user, be sure also to hand over the manual.**

— ⚠ WARNING —

- **The appliance must be stored in a room without continuously operating ignition sources (for example: open flames, an operating gas appliance or an operating electric heater).**
- **Do not pierce or burn.**
- **Be aware that refrigerants may not contain an odour.**
- **Floor area required for installation of the equipment, refer to the installation manual of the outdoor unit.**
- **Be aware that prolonged, direct exposure to cool air from the air conditioner, or to air that is too cool can be harmful to your physical condition and health.**
- **When the air conditioner is malfunctioning (giving off a burning odour, etc.) turn off power to the unit and contact your local dealer.**
Continued operation under such circumstances may result in a failure, electric shocks or fire hazards.

- **Consult your local dealer about installation work.**
Doing the work yourself may result in water leakage, electric shocks or fire hazards.
- **Consult your local dealer regarding modification, repair and maintenance of the air conditioner.**
Improper workmanship may result in water leakage, electric shocks or fire hazards.
- **Do not place objects, including rods, your fingers, etc., in the air inlet or outlet.**
Injury may result due to contact with the air conditioner's high speed fan blades.
- **Beware of fire in case of refrigerant leakage.**
If the air conditioner is not operating correctly, i.e. not generating cool air, refrigerant leakage could be the cause.
Consult your dealer for assistance.
The refrigerant within the air conditioner is safe and normally does not leak.
However, in the event of a leakage, contact with a naked burner, heater or cooker may result in generation of noxious gas.
Do not longer use the air conditioner until a qualified service person confirms that the leakage has been repaired.
- **Consult your local dealer regarding what to do in case of refrigerant leakage.**
When the air conditioner is to be installed in a small room, it is necessary to take proper measures so that the amount of any leaked refrigerant does not exceed the concentration limit in the event of a leakage. Otherwise, this may lead to an accident due to oxygen depletion.
- **Contact professional personnel about attachment of accessories and be sure to use only accessories specified by the manufacturer.**
If a defect results from your own workmanship, it may result in water leaks, electric shock or fire.
- **Consult your local dealer regarding relocation and reinstallation of the air conditioner.**
Improper installation work may result in leakage, electric shocks or fire hazards.
- **Be sure to use fuses with the correct ampere reading.**
Do not use improper fuses, copper or other wires as a substitute, as this may result in electric shock, fire, injury or damage to the unit.
- **Be sure to earth the unit.**
Do not earth the unit to a utility pipe, lightning conductor or telephone earth lead. Imperfect earthing may result in electric shocks or fire. A high surge current from lightning or other sources may cause damage to the air conditioner.
- **Be sure to install an earth leakage breaker.**
Failure to install an earth leakage breaker may result in electric shocks or fire.
- **Consult the dealer if the air conditioner submerges owing to a natural disaster, such as a flood or typhoon.**
Do not operate the air conditioner in that case, or otherwise a malfunction, electric shock, or fire may result.
- **Do not start or stop operating the air conditioner with the power supply breaker turned ON or OFF.**
Otherwise, fire or water leakage may result.
Furthermore, the fan will rotate abruptly if power failure compensation is enabled, which may result in injury.
- **Do not use the product in the atmosphere contaminated with oil vapor, such as cooking oil or machine oil vapor.**
Oil vapor may cause crack damage, electric shocks, or fire.
- **Do not use the product in places with excessive oily smoke, such as cooking rooms, or in places with flammable gas, corrosive gas, or metal dust.**
Using the product in such places may cause fire or product failure.

- **Do not place water containers (flower vases, etc.) on the unit, as this may result in electric shocks or fire.**
- **Do not operate with the control panel lid open.**
If water gets inside the panel, it may result in equipment failure or electric shock.
- **Do not use flammable materials (e.g., hairspray or insecticide) near the product.**
- **Do not place burners or heaters in places exposed to the air flow from the unit as this may impair combustion of the burner or heater.**
- **Do not wipe the controller panel with benzene or other organic solvent.**
This will cause discoloration and/or peeling. If the panel needs cleaning, use a damp cloth with some water-diluted neutral detergent. Wipe with a dry cloth afterwards.
- **Be sure to use a dedicated power supply for the air conditioner.**
The use of any other power supply may cause heat generation, fire, or product failures
- **Consult your dealer regarding cleaning the inside of the air conditioner.**
Improper cleaning may cause breakage of plastic parts, water leakage and other damage as well as electric shocks.

—  **CAUTION** —

- **Do not use the air conditioner for purposes other than those for which it is intended.**
Do not use the air conditioner for cooling precision instruments, food, plants, animals or works of art as this may adversely affect the performance, quality and/or longevity of the object concerned.
- **Do not remove the outdoor unit's fan guard.**
The guard protects against the unit's high speed fan, which may cause injury.
- **Do not place objects that are susceptible to moisture directly beneath the indoor or outdoor units.**
Under certain conditions, condensation on the main unit or refrigerant pipes, air filter dirt or drain blockage may cause dripping, resulting in fouling or failure of the object concerned.
- **To avoid oxygen depletion, ensure that the room is adequately ventilated if equipment such as a burner is used together with the air conditioner.**
- **After prolonged use, check the unit stand and its mounts for damage.**
If left in a damaged condition, the unit may fall and cause injury.
- **Do not place flammable sprays or operate spray containers near the unit as this may result in fire.**
- **Before cleaning, be sure to stop unit operation, turn the breaker off or remove the power cord.**
Otherwise, an electric shock and injury may result.
- **To avoid electric shocks, do not operate with wet hands.**
- **Do not place appliances that produce naked flames in places exposed to the air flow from the unit as this may impair combustion of the burner.**
- **Do not place heaters directly below the unit, as resulting heat can cause deformation.**
- **Do not allow a child to mount on the outdoor unit or avoid placing any object on it.**
Falling or tumbling may result in injury.
- **Do not sit or place objects on the outdoor unit.**
Falling yourself or falling objects could cause injury.

- **Do not block air inlets or outlets.**
Impaired air flow may result in insufficient performance or trouble.
- **Be sure that children, plants or animals are not exposed directly to airflow from the unit, as adverse effects may ensue.**
- **Do not wash the air conditioner with water, as this may result in electric shocks or fire.**
- **Arrange the drain hose to ensure smooth drainage.**
Imperfect drainage may cause wetting of the building, furniture etc
- **Ensure that the remote controller is not exposed to direct sunlight.**
This will cause discoloration of the LCD display with resulting loss of readability.
- **Never operate remote controller buttons with hard, pointed objects.**
This may result in remote controller damage.
- **Do not pull or twist the remote controller cord.**
This may cause malfunctioning.
- **Do not operate the air conditioner when using a room fumigation type insecticide.**
Fumigation chemicals deposited in the unit could endanger the health of those who are hypersensitive to touch chemicals.
- **Do not place flammable sprays near the unit as this can cause explosions.**
- **Do not install the air conditioner at any place where there is a danger of flammable gas leakage.**
In the event of a gas leakage, build-up of gas near the air conditioner may result in fire hazards.
- **Do not put flammable containers, such as spray cans, within 1 m from the blow-off mouth.**
The containers may explode because the warm air output of the indoor or outdoor unit will affect them.
- **Arrange the drain to ensure complete drainage.**
If proper drainage from the outdoor drain pipe does not occur during air conditioner operation, there could be a blockage due to dirt and debris build-up in the pipe. This may result in a water leakage from the indoor unit. Under these circumstances, stop air conditioner operation and consult your dealer for assistance.
- **The appliance is not intended for use by unattended young children or infirm persons.**
Impairment of bodily functions and harm to health may result.
- **Children should be supervised to ensure that they do not play with the unit or its remote controller.**
Accidental operation by a child may result in impairment of bodily functions and harm health.
- **Do not let children play on or around the outdoor unit.**
If they touch the unit carelessly, injury may be caused.
- **To avoid injury, do not touch the air inlet or aluminium fins of the unit.**
- **Do not place objects in direct proximity of the outdoor unit and do not let leaves and other debris accumulate around the unit.**
Leaves are a hotbed for small animals which can enter the unit. Once in the unit, such animals can cause malfunctions, smoke or fire when making contact with electrical parts.
- **Turn off the main power switch when the air conditioner is not to be used for prolonged periods.**
When the main power switch is left on, some electrical power (watts) is still consumed even if the air conditioner is not operating. Therefore, switch off the main power switch to save energy. When resuming operation, to ensure smooth running, turn on the main power switch 6 hours before operating the air conditioner again.

- **Never touch the internal parts of the controller.**
Do not remove the front panel. Touching certain internal parts will cause electric shocks and damage to the unit. Please consult your dealer about checking and adjustment of internal parts.
- **Do not leave the remote controller wherever there is a risk of wetting.**
If water gets into the remote controller there is a risk of electrical leakage and damage to electronic components.
- **Watch your steps at the time of air filter cleaning or inspection.**
High-place work is required, to which utmost attention must be paid.
If the scaffold is unstable, you may fall or topple down, thus causing injury.
- **This appliance is not intended for use by persons (including children) with reduced physical, sensory or mental capabilities, or lack of experience and knowledge, unless they have been given supervision or instruction concerning use of the appliance by a person responsible for their safety.**
- **Children should be supervised to ensure that they do not play with the appliance.**
- **Take care of scaffolding and exercise caution when working high above ground level.**

2. WHAT TO DO BEFORE OPERATION

This operation manual is for the following system with standard control. Before initiating operation, contact your dealer for the operation that corresponds to your system.

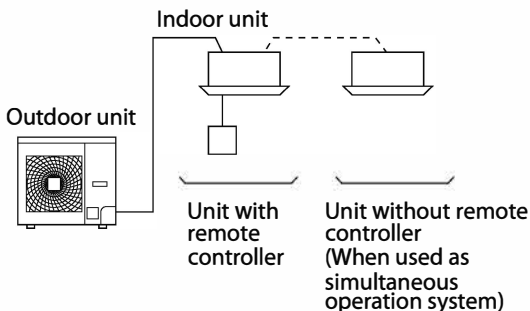

NOTE

- If the unit you purchased is controlled by a wireless remote controller, also refer to the wireless remote controller's operation manual.
- If your installation has a customized control system, ask your dealer for the operation that corresponds to your system.
- Heat pump type
This system provides COOLING, HEATING, AUTOMATIC, PROGRAM DRY, and FAN OPERATION modes.

PRECAUTIONS FOR GROUP CONTROL SYSTEM OR TWO REMOTE CONTROLLERS CONTROL SYSTEM

This system provides two other control systems beside individual control (one remote controller controls one indoor unit) system. Confirm the following if your unit is the following control system type.

- **Group control system**
One remote controller controls up to 16 indoor units. All indoor units are equally set.
- **Two remote controllers control system**
Two remote controllers control one indoor unit (In case of group control system, one group of indoor units).

NOTE

- Contact your local dealer in case of changing the combination or setting of group control and two remote controller control systems.
- Please do not change the combination and settings for the group operation and two remote controllers control systems by yourself, but be sure to ask your local dealer.

Names and functions of parts

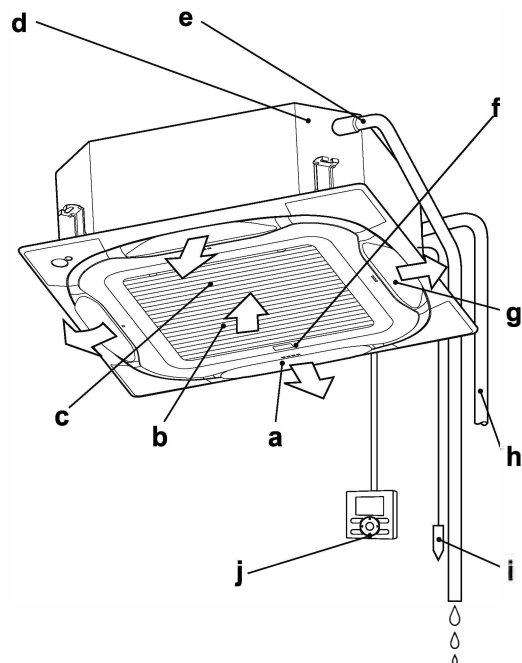

a	Air outlet
b	Suction grille
c	Air filter (Inside suction grille)
d	Drain discharge device (built-in) Discharges indoor moisture removed during the cooling operation.
e	Drain pipe
f	Brand name logo
g	Horizontal blade (At air outlet)
h	Refrigerant piping Transmission wiring
i	Earth wiring (Note) (Note) It is a wiring to let electricity flow from the indoor unit to the earth for prevention of electric shocks or a fire in case of emergency.
j	Remote control (Operation part) The remote controller may not be needed depending on the system configuration.

3. OPERATION RANGE

If the temperature or the humidity is beyond the following conditions, safety devices may work and the air conditioner may not operate, or sometimes, water may drop from the indoor unit.

COOLING

For FCFQ24CV1

OUTDOOR UNIT	INDOOR		OUTDOOR TEMPERATURE
	TEMPERATURE	HUMIDITY	
RZCF	DB	19 to 35	80% or below
	WB	14 to 24	
	DB		21 to 54

DB: Dry bulb temperature (°C)

WB: Wet bulb temperature (°C)

For setting temperature range of the remote controller, please refer manual attached with remote.

4. INSTALLATION SITE

Regarding places for installation

- **Is the air conditioner installed at a well-ventilated place where there are no obstacles around?**
- **Do not use the air conditioner in the following places.**
 - a. Filled with much mineral oil such as cutting oil
 - b. Where there is much salt such as a beach area
 - c. Where sulfured gas exists such as a hot-spring resort
 - d. Where there are considerable voltage fluctuations such as a factory or plant
 - e. Vehicles and vessels
 - f. Where there is much spray of oil and vapor such as a cookery, etc.
 - g. Where there are machines generating electromagnetic waves
 - h. Filled with acid and/or alkaline steam or vapor

- **Is a snow protection measure taken?**
For details, consult your dealer about snow protection hoods, etc.

Regarding wiring

- **All wiring must be performed by an authorized electrician.**
To do wiring, ask your dealer. Never do it by yourself.
- **Make sure that a separate power supply circuit is provided for this air conditioner and that all electrical work is carried out by qualified personnel according to local laws and regulations.**

Pay attention to running noises, too

- **Are the following places selected?**
 - a. A place that can sufficiently withstand the weight of the air conditioner with less running noises and vibrations.
 - b. A place where the hot wind discharged from the air outlet of the outdoor unit and the running noises do not cause a nuisance to neighbours.
- **Are you sure that there are no obstacles near the air outlet of the outdoor unit?**
Such obstacles may result in declined performance and increased running noises.
- **If abnormal noises occur in use, stop the operation of the air conditioner, consult your dealer.**

System relocation

- **Consult your Daikin dealer about remodelling and relocation.**

Regarding drainage of drain pipe

- **Is the drain pipe executed to perform complete drainage?**
If proper drainage is not carried out from the outdoor drain pipes during air-conditioning operation, chances are that dust and dirt are clogged in the pipe. This may result in a water leakage from the indoor unit. Under such circumstances, stop the operation of the air conditioner, and then consult your dealer or our service station.

5. OPERATION PROCEDURE

- **Operation procedure**
Read the operation manual attached to the remote controller.
- **Operation procedure varies with heat pump type and cooling only type.** Contact your local dealer to confirm your system type.
- **To protect the unit, turn on the main power supply switch 6 hours before operation.**
- **Do not shut off the power supply during seasonal use of the air conditioner.**
This is required in order to activate the air conditioner smoothly.
- **If the main power supply switch is turned off during operation, operation will restart automatically after the power truns back on again.**

6. OPERATION CHARACTERISTICS

■ CHARACTERISTICS OF THE COOLING OPERATION (COOLING OPERATION AND AUTOMATIC COOLING OPERATION)

- When operating continuously at downward airflow direction, air blows in the automatically set direction for a period of time to prevent condensation on the horizontal blade. (The remote controller displays the airflow direction that is set.)
- If the COOLING OPERATION is used when the indoor temperature is low, frost forms on the heat exchanger of the indoor unit. This can decrease the cooling capacity. In this case, the air conditioner automatically switches to the DEFROST OPERATION for a while. During the DEFROST OPERATION, the low fan speed is used to prevent the discharge of melt water. (The remote controller displays the fan speed that is set.)
- When the outdoor temperature is high, it takes some time until the indoor temperature reaches the set temperature.

■ CHARACTERISTICS OF THE HEATING OPERATION (HEATING OPERATION AND AUTOMATIC HEATING OPERATION)

START OF OPERATION

- It generally takes a longer time for indoor temperature of the HEATING OPERATION to reach the set temperature compared to the COOLING OPERATION. It is advisable to start operation in advance using the TIMER OPERATION.

Perform the following operation to prevent heating capacity decrease and discharge of cool air.

AT THE START OF OPERATION AND AFTER THE DEFROST OPERATION

- A warm air circulating system is employed, and therefore it takes some time until the entire room is warmed up after the start of operation.
- The indoor fan runs to discharge a gentle wind automatically until the temperature inside the air conditioner reaches a certain level. At this time, the remote controller displays “”. Leave it as it stands and wait for a while. (The remote controller displays the fan speed that is set.)
- The airflow direction becomes horizontal to prevent a draft of cool air to the inhabitants. (The remote controller displays the airflow direction that is set.)

DEFROST OPERATION

(Frost removal operation for the outdoor unit)

- As the frost on the coil of an outdoor unit increase, heating effect decreases and the air conditioner goes into the DEFROST OPERATION.
- The indoor unit fan stops and the remote controller display shows “”. With the wireless remote controller, the warm air stops, and the DEFROST OPERATION lamp on the light receiving unit turn on. (The remote controller displays the fan speed that is set.)
- After maximum 10 minutes of the DEFROST OPERATION, the air conditioner returns to the HEATING OPERATION.
- The airflow direction becomes horizontal. (The remote controller displays the airflow direction that is set.)

- During or after the DEFROST OPERATION, white mist comes out from the air inlet or outlet of the air conditioner. (Refer to “6.” on page 64.)
- A hissing and “Shuh” sound may be heard during this particular operation.

Regarding outside air temperature and heating capacity

- The heating capacity of the air conditioner declines as the outside air temperature falls. In such a case, use the air conditioner in combination with other heating systems. (When a combustion appliance is used, ventilate the room regularly.) Do not use the combustion appliance where the air from the air conditioner is blown directly toward it.
- When the warm air stays under the ceiling and your feet are cold, we recommend that you use a circulator (a fan to circulate the air inside the room). For details, consult your local dealer.
- When the indoor temperature exceeds the set temperature, the indoor unit discharges a gentle breeze (switches to gentle wind). The airflow direction becomes horizontal. (The remote controller displays the fan speed and airflow direction that are set.)

■ CHARACTERISTICS OF THE PROGRAM DRY OPERATION

- This operation lowers the humidity without lowering the indoor temperature. The indoor temperature when the operation button is pressed will be the set temperature. At this time, the fan speed and temperature are set automatically, so the remote controller does not display the fan speed and set temperature. To efficiently lower the indoor temperature and humidity, first use the COOLING OPERATION to lower the indoor temperature, and then use the PROGRAM DRY OPERATION. When the indoor temperature is lowered, airflow from the air conditioner may stop.
- When operating continuously at downward airflow direction, air blows in the automatically set direction for a period of time to prevent condensation on the horizontal blade. (The remote controller displays the airflow direction that is set.)
- If the PROGRAM DRY OPERATION is used when the indoor temperature is low, frost forms the heat exchanger of the indoor unit. In this case, the air conditioner automatically switches to the DEFROST OPERATION for a while. The low fan speed or a gentle wind is used to prevent the discharge of melt water.



AIRFLOW DIRECTION ADJUST

Airflow direction adjustment can be done by remote controller. For details about airflow direction adjustment, refer to operation manual attached to remote controller.

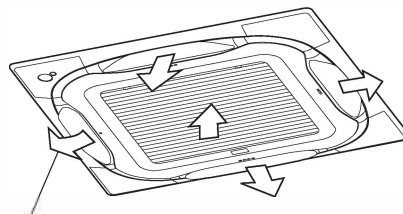

Up and down adjustment

The airflow direction can be adjusted in either of the following.

- **Swing**
The horizontal blade continuously varies.
- **Fixed airflow direction**
The horizontal blade can be fixed by the user.

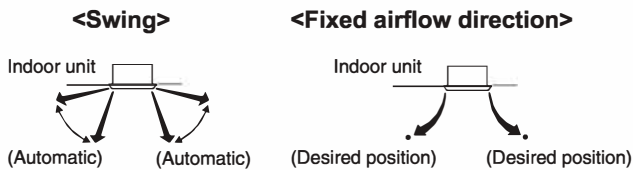

MOVEMENT OF THE HORIZONTAL BLADE

For the following conditions, micro computer controls the airflow direction so it may be different from the display.

Operation mode	<ul style="list-style-type: none"> • COOLING • AUTOMATIC COOLING • PROGRAM DRY 	<ul style="list-style-type: none"> • HEATING • AUTOMATIC HEATING
Up and down direction	<ul style="list-style-type: none"> • When operating continuously at horizontal airflow direction (Air blows in the automatically set direction for a period of time to prevent condensation on the horizontal blades.) 	<ul style="list-style-type: none"> • When room temperature is higher than the set temperature • When the HEATING OPERATION starts or during the DEFROST OPERATION (if frost forms on the outdoor unit) (The airflow direction becomes horizontal so that it does not blow directly toward your body.)

NOTE

- When group control is performed on the simultaneous operation system (twin, triple and double twin), airflow direction cannot be individually set on the slave units.

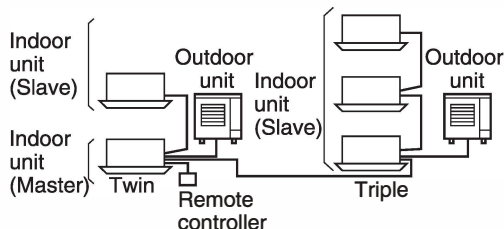

Recommended airflow direction positions

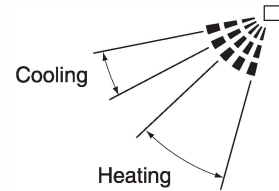

We recommend using the fan in the position shown above when fixing the fan direction.

7. OPTIMUM OPERATION

Observe the following precautions to ensure the system operates.

- Adjust the room temperature properly for a comfortable environment. Avoid excessive heating or cooling.
- Prevent direct sunlight from entering a room during cooling operation by using curtains or blinds.
- Keep doors and windows closed. If the doors and windows remain open, room air will flow out and cause to decrease the effect of cooling and heating.
- Never place objects near the air inlet and the air outlet of the unit. It may cause deterioration in the effect or stop in the operation.
- Install TVs, radios, and stereos 1 m or more away from the indoor unit and remote controller. Images may become fuzzy and noise may be generated.
- Turn off the main power supply switch when it is not used for long periods of time. When the main power supply switch is turned on, some watts of electricity is being used even if the system is not operating. (*1) Turn off the main power supply switch for saving energy. When reoperating, turn on the main power supply switch 6 hours before operation for smooth running (Refer to "8. MAINTENANCE" on page 61.). (*2)
- *1 The consumed power while the outdoor unit is not in operation depends on the model.
- *2 The setting before the power circuit breaker is cut off is stored. (The timer setting is cleared.)
- When the display shows "TIME TO CLEAN AIR FILTER" ask a qualified service person to clean the filter (Refer to "8. MAINTENANCE" on page 61.).
- Fully use the function of air flow direction adjust. Cold air gathers on the floor, and warm air gathers in the ceiling. Set the air direction to horizontal during the COOLING or PROGRAM DRY OPERATION, and set it downwards during the HEATING OPERATION. Do not let the air blow directly to a person.
- It takes time for the room temperature to reach the set temperature. We recommend starting the operation in advance using timer operation.

8. MAINTENANCE (FOR SERVICE PERSONNEL)

ONLY A QUALIFIED SERVICE PERSON IS ALLOWED TO PERFORM MAINTENANCE

⚠ WARNING

- Do not use flammable gas (such as hair sprays and insecticides) near the air conditioner.
- Do not wipe the air conditioner with benzine or thinner.
It may cause cracks, electric shocks or a fire.
- Never put your fingers or rods in the air inlet, air outlet or air blade.
The fan is rotating at high speed, so you would get injured.

⚠ CAUTION

- Do not wash the air conditioner with water. It may cause electric shocks or a fire due to leakage.
- Make sure to turn off the air conditioner when taking care of the air conditioner and disconnect the power supply breaker.
Unless the power supply is disconnected, it may cause electric shocks and injuries.
- When working at a high place, give caution to your footing.
If the scaffold is unstable, it may cause injuries due to fall and stumbling.

NOTE

- Do not remove the air filter unless for cleaning. It may cause failure.
- Do not attach substance (such as paper towels) other than the specified air filter to the air inlet.
The performance may drop and cause freeze-up/ water leakage.

HOW TO CLEAN THE AIR FILTER

When the remote controller indicates "Time to clean filter", clean the air filter.

- It indicates after running for a certain time.

NOTE

- You may change the time of indication "Time to clean filter".

If the indoor unit is used in a space where the air is more contaminated, ask your local dealer for solution.

Contamination	Time until indication is displayed
Normal	2500 hours (equivalent to 1 year)
More contaminated	1250 hours (equivalent to 6 months)

- If it becomes difficult to remove contamination from the air filter, replace the air filter.
(Air filter for replacement is an optional accessory)

1. Open the suction grille.

Pull it downward slowly while pressing the buttons provided on two spots.

(Do the same procedure for closing.)

Fig. 1

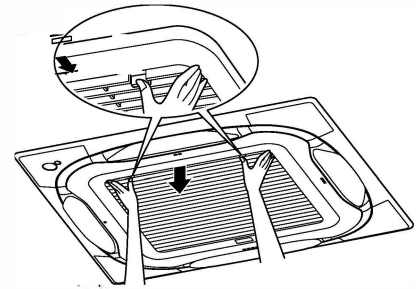

2. Remove the air filter.

Perform the operation in the order (1) and (2).

Fig. 2

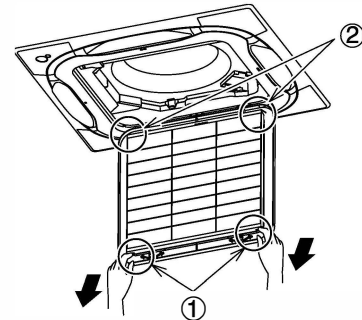

- (1) Pull the ends of the air filter down and remove the holes of the air filter from the grille protrusions. (Both left and right sides.)

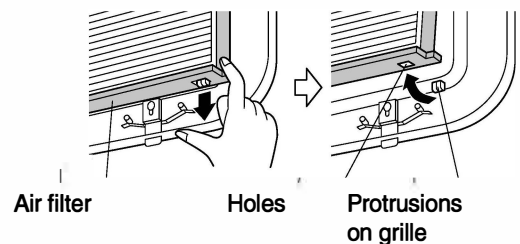

- (2) Lift the air filter and remove the holes of the air filter from the protrusions on the upper side of the grille. (Both left and right sides.)

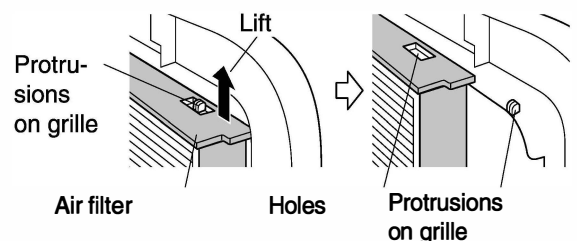

3. Clean the air filter.

A) Use vacuum cleaner B) or wash the air filter with water

A) Using a vacuum cleaner



- B) Washing with water
When the air filter is very dirty, use soft brush and neutral detergent.



Remove water and dry in the shade.

NOTE

- Do not wash the air filter with water of 50°C or higher. It may cause discoloration and deformation.
 - When drying the filter, do not heat it with fire. It may cause burning.
 - Do not use such as gasoline, benzene, thinner, polishing powder and liquid insecticide sold in the market. It may cause discoloration and deformation.
4. Fix the air filter.
Refer to item No. 2.
 5. Shut the suction grille.
Slowly push up the suction grille, and then securely hook it onto the decoration panel while pushing the two knobs.

NOTE

- The strings may be caught when the suction grille is closed. Before closing the suction grille, ensure that the strings are not getting out from the side of the suction grille.

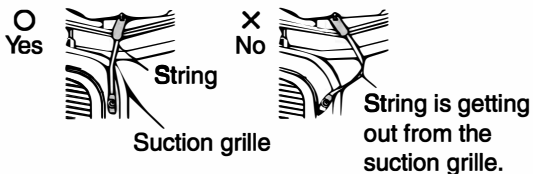

6. Turn off the indication "Time to clean filter" displayed on the remote controller after turning on the power.
 - For details, refer to the operation manual attached to the remote controller. (The indication can be turned off whether in operation or at stop.)

HOW TO CLEAN AIR OUTLET, OUTSIDE PANEL, AND REMOTE CONTROLLER

- Wipe them with a dry soft cloth.
- When the stain cannot be wiped off, dip the cloth in the neutral detergent diluted with water and twist the cloth. After wiping off stain with this cloth, wipe them with dry cloth.

NOTE

- Do not use such as gasoline, benzene, thinner, polishing powder and liquid insecticide sold in the market. It may cause discoloration and deformation.
- Do not wash the filter with warm water of 50°C or higher. It may cause discoloration and deformation.

HOW TO CLEAN THE SUCTION GRILLE

1. Open the suction grille.
Push it downward slowly while pressing the buttons provided on two spots. (Follow the same procedure for closing.)

Fig. 3

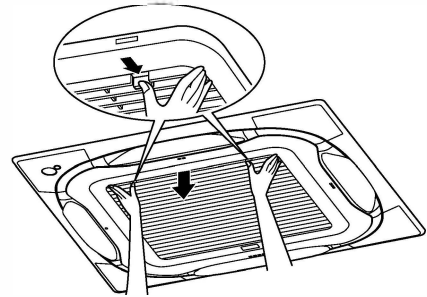

2. Remove the strings of the suction grille.
Remove the two strings from the holding parts on the panel main body to which the strings are attached.

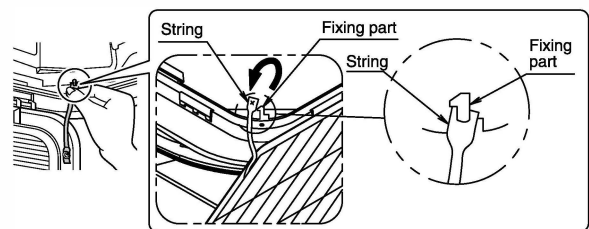

3. Detach the suction grille.
Open the suction grille 45 degrees and lift it upward.

Fig. 4

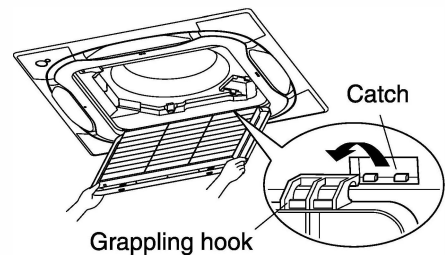

4. Detach the air filter.
Refer to "HOW TO CLEAN THE AIR FILTER". (Refer to Fig. 2)

5. Clean the suction grille.
Wash with a soft bristle brush and neutral detergent or water, and dry thoroughly.

- **When very grimy**
Directly apply the type of detergent used for cleaning ventilation fans or ovens, wait 10 minutes, and then rinse with water.



NOTE

- Do not wash the suction grille with water of 50°C or higher. It may cause discoloration and deformation.
- When drying the suction grille, do not heat it with fire. It may cause burning.
- Do not use such as gasoline, benzene, thinner, polishing powder and liquid insecticide sold in the market. It may cause discoloration and deformation.

6. **Reattach the air filter.**
Refer to "HOW TO CLEAN THE AIR FILTER".
(Refer to Fig. 2)
7. **Reattach the suction grille.**
Refer to item No. 2.
8. **Fit the string of the suction grille.**
Fit in the reverse order of the procedure 2.
9. **Close the suction grille.**
Refer to item No. 1.

■ CLEANING BEFORE AND AFTER SEASONAL USE

WHAT TO DO WHEN START UP AFTER A LONG STOP

Confirm the following.

- Check that the air inlet and outlet of indoor and outdoor unit are not blocked.
Remove any obstacle.
Obstacles may cause a reduction in the fan speed, which may decrease functionality, cause an increase in operation noise, or a malfunction of the equipment.

Clean the air filter and outside panel

- After cleaning the air filter, make sure to attach it.
(Refer to "8. MAINTENANCE" on page 61.)
- For information on how to install, remove, or clean a optional sold air filter, refer to the user's manual attached to the air filter.
- After cleaning, perform FILTER SIGN RESET after turning on the power.

Turn on the power circuit breaker at least 6 hours before operation.

- This is required in order to activate the air conditioner smoothly, and to protect air conditioner.
- The display on the remote controller will be shown when the power circuit breaker is turned on.

HEATING OPERATION within 6 hours after the power is supplied to the air conditioner.

- Some models perform the following operation to protect the devices.
If the HEATING OPERATION is performed within 6 hours after the power is supplied to the air conditioner, the indoor fan stops for about 10 minutes during the outdoor unit operation to protect the devices. The above operation is performed not only at the time of installation, but every time the power circuit breaker is turned off/on.
For comfortable use, do not turn off the power circuit breaker during seasonal use of the HEATING OPERATION.

WHAT TO DO TO STOP THE AIR CONDITIONER FOR A LONG PERIOD

Turn on FAN OPERATION for a half day on the fine day and dry the indoor unit.

- This can prevent the causes of mould.

Turn off the power circuit breaker.

- During the power circuit breaker is turned on, some watts of electricity is being used even if the air conditioner is not operating.
Turn off the power circuit breaker for saving energy.
- The display on the remote controller will vanish when the power circuit breaker is turned off.

Clean the air filter and outside panel

- Be sure to replace the air filter to its original place after cleaning. (Refer to "8. MAINTENANCE" on page 7.)
For information on how to install, remove, or clean an optional sold air filter, refer to the user's manual attached to the air filter.

NOTE

The inside of the air conditioner may become contaminated after several seasons of use, potentially causing performance degradation and water leakage.
Ask your local dealer for details on cleaning the inside of the indoor unit. This operation requires a qualified service person.

9. NOT MALFUNCTION OF THE AIR CONDITIONER

The following symptoms do not indicate air conditioner malfunction.

- **HEATING OPERATION** within 6 hours after the power is supplied to the air conditioner.
Some models perform the following operation to protect the devices.
If the HEATING OPERATION is performed within 6 hours after the power is supplied to the air conditioner, the indoor fan stops for about 10 minutes during the outdoor unit operation to protect the devices. The above operation is performed not only at the time of installation, but every time the power circuit breaker is turned off/on.
For comfort heating, it is recommended not to turn off the power circuit breaker during the HEATING OPERATION.

1. THE AIR CONDITIONER DOES NOT OPERATE

- **The air conditioner does not restart immediately after the ON/OFF button is pressed.**
- **The air conditioner does not restart immediately when TEMPERATURE SETTING button is returned to the former position after pushing the button.**
If the OPERATION lamp lights, the air conditioner is in normal condition.
It does not restart immediately because a safety device operates to prevent overload of the air conditioner.
After approx. 3 minutes, the air conditioner will turn on again automatically.
- **The air conditioner does not start when the display shows "  " and it flashes for few seconds after pressing an operation button.**
This is because the air conditioner is under centralized control.
Flashes on the display indicates that the air conditioner cannot be controlled by the remote controller.
- **HEATING OPERATION within 6 hours after the power is supplied to the air conditioner.**
Some models perform the following operation to protect the devices.
If the HEATING OPERATION is performed within 6 hours after the power is supplied to the air conditioner, the indoor fan stops for about 10 minutes during the outdoor unit operation to protect the devices. The above operation is performed not only at the time of installation, but every time the power circuit breaker is turned off/on.
For comfortable use, do not turn off the power circuit breaker during seasonal use of the HEATING OPERATION.

- **The outdoor unit stops.**
This is because the indoor temperature has reached the set temperature.
The indoor unit is in the FAN OPERATION.
COOLING OPERATION
(AUTOMATIC COOLING OPERATION):
Lower the set temperature.
HEATING OPERATION
(AUTOMATIC HEATING OPERATION):
Raise the set temperature.
The operation starts after a while when the air conditioner is in normal condition.
- **The remote controller displays “/” and airflow stops.**
This is because the air conditioner automatically switches to the DEFROST OPERATION to prevent a decrease in heating capacity when frost on the outdoor unit increases.
After maximum 10 minutes, the air conditioner returns to its original operation.

2. THE OPERATION SOMETIMES STOPS

- **The remote controller displays “U4” and “U5”, and the operation stops. However, it will restart in a few minutes.**
This is because communication between the indoor and outdoor units or indoor units and remote controllers is shut off and stops the operation due to noise caused by devices other than the air conditioner.
When the electrical noise decreases, the air conditioner automatically restarts.

3. THE FAN SPEED IS DIFFERENT FROM THE SETTING

- **Pressing the fan speed control button does not change the fan speed.**
During the COOLING OPERATION, the low fan speed or a gentle wind is used to prevent the discharge of melt water.
During the DEFROST OPERATION (HEATING OPERATION), the wind from the air conditioner stops to prevent air discharge directly toward your body.
After a while, the fan speed can be changed.
(The fan speed cannot be set for the PROGRAM DRY OPERATION.)
When the room temperature reaches the set temperature during the HEATING OPERATION, the outdoor unit stops and the indoor unit goes into gentle wind.
It takes some time until the fan speed changes.
Raise the set temperature. After a while, the fan speed changes.

4. THE AIRFLOW DIRECTION IS DIFFERENT FROM THE SETTING, OR THE AIRFLOW DIRECTION IS DIFFERENT FROM THE DISPLAY ON THE REMOTE CONTROLLER

- **The horizontal blades do not swing when the remote controller displays the swing operation.**
<HEATING OPERATION>
This is because the airflow direction is controlled so it is horizontal direction after the operation starts or when the indoor temperature is higher than the set temperature to prevent air discharge directly toward your body.
After a while, the swing operation starts.
(Refer to “MOVEMENT OF THE HORIZONTAL BLADE” page61.)

- **The airflow direction display of the remote controller differs from the actual operation of the horizontal blades.**
<COOL AND PROGRAM DRY OPERATIONS>
When the operation in a downward airflow direction is set, the airflow direction differs from the display for a period of time to prevent condensation on the horizontal blades.
<HEATING OPERATION>
This is because the airflow direction is controlled so it is horizontal direction after the operation starts or when the indoor temperature is higher than the set temperature to prevent air discharge directly toward your body.
After a while, the airflow direction changes to the set direction.
(Refer to “MOVEMENT OF THE HORIZONTAL BLADE” page61.)

5. HORIZONTAL BLADES DO NOT CLOSE

- **The horizontal blades do not close even when operation stops.**
This is because the horizontal blades close once airflow from the air conditioner stops. After a while, the horizontal blades close.

6. WHITE MIST COMES OUT OF THE AIR CONDITIONER

- **When humidity is high during the COOLING OPERATION (In oily or dusty places)**
If the inside of an indoor unit is extremely contaminated, the temperature distribution inside a room becomes uneven. It is necessary to clean the inside of the indoor unit. Ask your local dealer for details on cleaning the indoor unit.
This cleaning requires a qualified service person.
Check the usage environment.
- **When the air conditioner is changed over to the HEATING OPERATION after the DEFROST OPERATION and in the DEFROST OPERATION.**
Moisture generated by defrost becomes steam and will float around. When the remote controller display shows “”, DEFROST OPERATION is being used.

7. NOISE OF AIR CONDITIONERS

- **A ringing sound after the indoor unit starts.**
This sound is generated when the motors for driving the horizontal blades are working. It will quiet down after about a minute.
- **A low continuous flow “Shuh” sound which is heard when the air conditioner is in the COOLING or DEFROST OPERATION or a trickling sound which is heard when the air conditioner is in the DEFROST OPERATION.**
This is the sound of refrigerant gas flowing through both indoor and outdoor units.
- **A “Shuh” sound which is heard at the start or immediately after the stop of operation or which is heard at the start or immediately after the stop of the DEFROST OPERATION.**
This is the noise of refrigerant caused by flow stop and flow change.
During the HEATING OPERATION, the air conditioner switches to the DEFROST OPERATION automatically.
The remote controller shows “”.
After maximum 10 minutes, the air conditioner returns to its original operation.

- A “Pishi-pishi” squeaking sound is heard when the air conditioner is in operation or after the stop of operation.

Expansion and contraction of resin parts caused by temperature change makes this noise.

- **Draining water or motor rotation sound after the indoor unit stop.**

This sound is heard when cooling operation stop, the drain pump operates and then stop.

Wait approximately 5 minutes.

8. DUST FROM THE INDOOR UNITS

- **Dust may blow out from the unit after starting operation from long resting time.**

Dust absorbed by the unit blows out.

9. THE INDOOR UNITS GIVE OFF ODOURS

- **During operation**

The unit absorbs the smell of rooms, furniture, cigarettes, etc., and then emits them.

If odour is a concern, you can set to zero fan speed when the indoor temperature reaches the set temperature.

For details, contact your local dealer.

10. THE AIR CONDITIONER DOES NOT COOL EFFECTIVELY

- **The air conditioner is operating in the PROGRAM DRY OPERATION.**

This is because program dry mode operates so that the indoor temperature decreases as little as possible. Lower the indoor temperature using the COOLING OPERATION, and then use the PROGRAM DRY OPERATION.

(Refer to “CHARACTERISTICS OF THE PROGRAM DRY OPERATION” on page 59.)

- **Read through characteristics of the COOLING OPERATION, characteristics of the HEATING OPERATION, and characteristics of the PROGRAM DRY OPERATION on page 59.**

Read the operation manual that attached to the outdoor unit.

10. TROUBLE SHOOTING

Please check before requesting a service.

1. **If the air conditioner does not operate at all.**

- Check if fuse has blown.
Turn off the power supply.
Contact your local dealer.
- Check if the power circuit breaker is blown.
If the tab of power circuit breaker is in the OFF position, turn the power on with the power circuit breaker switch.
If the tab of power circuit breaker is in the trip position do not turn the power on with the power circuit breaker switch.
Contact your local dealer.

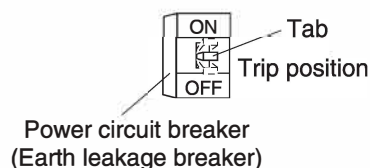

- Check if there is a power failure.
Wait until power is restored. If power failure occurs during operation, the air conditioner automatically restarts immediately after the power supply recovers.

2. **If the air conditioner stops after operating the air conditioner.**

- Check if the air inlet or outlet of outdoor or indoor unit is blocked by obstacles.
Remove the obstacle and make it well-ventilated.
The horizontal blades at the air outlet are closed while the indoor stops.
- Check if the air filter is clogged. Ask a qualified service person to clean the air filters.
A decrease in the airflow volume of the air conditioner will result and the performance of the air conditioner will be degraded and power consumption will increase if the air filter is clogged with dust or dirt.
In addition, this may cause dew condensation at the air outlet.
(Refer to “8. MAINTENANCE” on page 61.)

3. **The air conditioner operates but it does not sufficiently cool or heat.**

- Check if the air inlet or outlet of outdoor or indoor unit is blocked by obstacles. Remove the obstacle and make it well-ventilated.
The horizontal blades at the air outlet are closed while the unit stops.
Obstacles decrease the fan speed, and cause performance decrease and breakage when discharged air is suctioned.
They cause a waste of electricity, increase operating noise, or that may stop the devices.
 - Check if the air filter is clogged. Ask a qualified service person to clean the air filters.
A decrease in the airflow volume of the air conditioner will result and the performance of the air conditioner will be degraded and power consumption will increase if the air filter is clogged with dust or dirt.
In addition, this may cause dew condensation at the air outlet.
(Refer to “8. MAINTENANCE” on page 61.)
 - Check if the set temperature is not proper.
Set to an appropriate temperature, fan speed, and discharge direction.
 - Check if the FAN SPEED button is set to LOW SPEED.
Set to an appropriate temperature, fan speed, and discharge direction.
 - Check if the airflow direction is not proper.
Set to an appropriate temperature, fan speed, and discharge direction.
 - Check if the doors or the windows are open.
Shut doors or windows to prevent wind from coming in.
 - Check if the ventilation fan is in operation.
 - Check if direct sunlight enters the room (when cooling).
Use curtains or blinds.
 - When there are too many inhabitants in the room (when cooling).
 - Check if the heat source of the room is excessive (when cooling).
4. **Operation was performed or stopped although the ON/OFF button was not pressed.**
- Are you sure that the ON/OFF timer operation is not used?
Turn off the ON/OFF timer.
Please refer to operation manual attached to the remote controller.
 - Are you sure that any remote control device is not connected?
Contact the central control room that directed the stop.
 - Are you sure that the display for centralized control is not lit?
Contact the central control room that directed the stop.

If the problem is not solved after checking the above points, please do not try to repair it yourself. In such cases, always ask your local dealer. At this time, please tell the symptom and model name (written on the model name plate).

If one of the following malfunctions occurs, take the measures shown below and contact your local dealer.

The air conditioner must be repaired by a qualified service person.

—  **WARNING** —

When the air conditioner is malfunctioning (giving off a burning odour, etc.) turn off power to the air conditioner and contact your local dealer.

Continued operation under such circumstances may result in a failure, electric shocks or a fire. Contact your local dealer.

- If a safety device such as a fuse, a power circuit breaker or an earth leakage breaker frequently actuates;
Measure: Do not turn on the main power switch.
- If the ON/OFF switch does not properly work;
Measure: Turn off the main power switch.
- If water leaks from the indoor unit.
Measure: Stop the operation.
- If a malfunction occurs, either one of the following messages will appear on the Basic screen on the wired remote controller during operation.
“Error: Push Menu button.”
(* The Operation lamp will blink.)
“Warning: Push Menu button.”
(* The Operation lamp will not blink.)
- Press Menu/Enter button.
The Malfunction (Error) code blinks.
For more information, refer to the operation manual attached to the remote controller.
Measure: Notify your local dealer and inform malfunction code of the display.

Read the operation manual attached to the outdoor unit.

DAIKIN**DAIKIN AIRCONDITIONING INDIA PVT. LTD.**

210, 1st FLOOR, OKHLA INDUSTRIAL AREA, PHASE 3, DELHI-110020

PROTECT THE ENVIRONMENT FROM E-WASTE (GUIDELINES)

Meaning of E-waste under E-Waste (Management) Rules,2022 (E-waste Rules)
 -Waste electrical and electronic equipment, whole or in part of reject from their manufacturing and repair process, which are intended to be discarded.
 Our product is RoHS compliant.

**Don't dump Electrical and Electronic Products in Garbage Bins****DO'S & DONT'S**

DO'S	
Run and maintain the air conditioner as per the instructions given in the operation / instruction manual	✓
Ensure that an authorised person repairs your air conditioner	✓
Call our local authorised dealer or our toll free number to dispose your air conditioner	✓
Contact an authorised dealer in case of installation or de-installation	✓
Consult our local authorised dealer or our toll free number on the life span of the air conditioner	✓

DONT'S	
Do not try to repair your air conditioner on your own	✗
Do not sell or dispose your air conditioner or parts to an unauthorised Kabbadi wala / Scrap Dealer / Ragpickers	✗
Do not dismantle your air conditioner on your own	✗
Do not get your air conditioner or any parts repaired by an unauthorised person	✗
Do not dispose off the E-waste in landfills	✗
Do not use the air conditioner as furniture after its use	✗

****Customer Contact Center : 011-4031 9300/1860-180-3900**
For further information visit us at www.daikinindia.com

**The Customer contact center details are applicable for the models sold in India.

- In the event that there is any conflict in the interpretation of this manual and any translation of the same in any language, the English version of this manual shall prevail.
- The manufacturer reserves the right to revise any of the specification and design contain herein at any time without prior notification.

DAIKIN AIRCONDITIONING INDIA PVT. LTD.

*12th floor, Building No. 9,
Tower A, DLF Cyber City, DLF Phase-III
Gurgaon - 122002, Haryana (India)
Tel: 0124-4555444
Fax: 0124-4555333*