

DAIKIN



INSTALLATION MANUAL

SPLIT SYSTEM

Air Conditioners

MODELS

Ceiling Mounted Cassette type (Single Flow model)

FKCF71CRV16

**CAREFULLY READ THESE INSTRUCTIONS BEFORE INSTALLATION.
KEEP THIS MANUAL IN A HANDY PLACE FOR FUTURE REFERENCE.**

SPLIT SYSTEM air conditioners

CONTENTS

1.Safety precautions	2-3
2.Before installation	4
2-1.Caution	4
2-2.Accessories	4
2-3.Optional accessories	4-5
3.Selecting installation locations	5-6
4.Preparations before installation	6
5.Indoor unit installation	6-7
6.Decorative panel installation.....	7
7.Refrigerant piping installation	7-8
8.Drain piping installation	8-10
9.Electrical wiring work	10
9-1.Overview	10
9-2.Specifications of the standard electric wires.....	10
9-3.Electrical characteristics	10
10.Wiring example and how to set the remote controller....	10
10-1.How to connect wiring	10-11
10-2.Wiring example	11-12
10-3.Two remote controllers control one indoor unit.	12
10-4.Computerised Control ("Forced OFF"& "ON/OFF")	13
10-5.Centralized control	13
10-6.Panel wire connecting	13
11.Decorative panel installation for test run	13
12.Field settings and test run	13
12-1.Setting when an optional accessory is attached...	13
12-2.When using wireless remote controller.....	13
12-3.Setting fan speed during thermostat off.....	13
12-4.Setting filter sign.....	13-14
13.Test operation.....	14
13-1.Malfunction code list.....	14-15

Important information regarding the refrigerant used

This product contains fluorinated greenhouse gases.

Do not vent gases into the atmosphere.

Refrigerant type: R32

GWP⁽¹⁾ value: 675

⁽¹⁾GWP = global warming potential

The refrigerant quantity is indicated on the unit name plate.

1. SAFETY PRECAUTIONS



Read the precautions in this manual carefully before operating the unit.



This appliance is filled with R32.

The air conditioner is Grade A product. When used at home, this product may cause radio frequency interference. If this phenomenon occurs, the user may be required to take relevant measures.

Please read these "Safety precautions" carefully before installing the air conditioner and be sure to install it correctly.

After completing the installation, make sure that the unit operates properly during the start-up operation.

Please instruct the customer on how to operate the unit and keep it maintained.

Also, inform customers that they should store this installation manual along with the operation manual for future reference. This air conditioner is sold as the "appliance not accessible to the general public". The precautions described herein are categorized into two types. Strictly follow the instructions below as they are extremely important to your safety.

⚠ WARNING..... Failure to follow these instructions may result in death or serious injury.

⚠ CAUTION..... Failure to follow these instructions may result in injury or property damage, or even serious injury under some circumstances.

After completing installation, perform a test run to check for normal operation and explain to the users how to operate and maintain the air conditioner. In addition, ask the users to keep this operation & installation manual for future reference.

— ⚠ WARNING —

- Always ask the sales agency or specialized personnel to carry out the installation work. Do not attempt to install the unit by yourself.
Improper installation may result in water leakage , electric shocks or fire hazards.
- Install the air conditioner following the instructions contained in this manual.
Improper installation may result in water leakage , electric shocks or fire hazards.
- When installing in a small room, it is necessary to take proper measures to ensure the amount of any leaked refrigerant under the concentration limit in the event of a leakage. Contact your sales agency for appropriate measures. Excessive refrigerant concentration in a closed ambient space may result in oxygen deficiency.
- Be sure to use the specified accessories and parts for installation.
Failure to use the specified accessories and parts may result in the unit falling, water leakage, electric shocks, fire hazards or the unit failing to operate normally.
- Install the unit on a solid foundation which can withstand the weight of the unit.
A foundation of insufficient strength may result in the unit falling and causing damage and injuries.
- Reinforcement may be necessary for installation by taking into consideration strong winds, typhoons and earthquakes. Improper installation may result in the unit falling and causing accidents.
- Make sure that a separate power supply circuit is provided for the unit and that all electrical work is carried out by qualified electricians in accordance with your local laws and regulations as well as this manual. An insufficient power supply capacity or improper electrical operation may lead to electric shocks or fire hazards.
- Use the specified wires and attach them securely, with no external forces acting on the terminal connections or wires. Improper wiring or installation may cause fire hazards.

- When connecting the power supply wiring, remote controller wiring and transmission wiring, lay the wires in a smooth and regular way so that the electrical component box cover can be securely fastened.
Improper fastening of the cover may result in electric shocks, fire hazards or the electrical component box abnormal heating.
- If refrigerant leakage occurs during installation, immediately open the windows and doors for ventilation. Gaseous refrigerant will produce toxic gas if it comes into contact with fire.
- After completing all installation work, check for refrigerant leakage.
Toxic gas may be produced if the refrigerant gas leaks into the room and comes into contact with a source of fire, such as an air heater, stove or furnace.
- Do not touch the electrical parts when the unit is powered on.
- Do not touch the switches with the wet hands. Failure to do so may result in electric shocks.
- Be sure to earth the unit.
Do not connect the earth wire to the gas pipes, water pipes, lightning rods or telephone earth wires.
Improper earthing may result in electric shocks.
- Be sure to install the earth leakage circuit breaker.
Failure to do so may result in electric shocks or fire hazards.
- The indoor unit should be installed at the place out of the reach of children. (At least 2.5m above the ground)
- Do not directly touch refrigerant that has leaked from refrigerant pipes or other areas, as there is a danger of frostbite.

⚠ CAUTION

- Do not allow children to climb on the outdoor unit and avoid placing objects on the unit. Injury may result if the unit becomes loose and falls.
- Make sure to provide for adequate measures in order to prevent that the outdoor unit be used as a shelter by small animals.
Small animals making contact with electrical parts can cause malfunctions, smoke or fire. Please instruct the customer to keep the area around the unit clean.
- Install in a machine room that is free of moisture. The unit is designed for indoor use.
- Remote controller (wireless kit) transmitting distance can be shorter than expected in rooms with electronic fluorescent lamps (inverter or rapid start types). Install the indoor unit as far away from fluorescent lamps as possible.
- Install the drain pipe according to the manual to ensure proper drainage, and insulate the pipe to prevent condensation.
Improper drain pipe installation may result in water leakage and household items being wetted.
- Install the indoor unit, outdoor unit, power wiring and connecting wire at least 1m away from televisions or radios to prevent electromagnetic interference and noise. (A distance of 1m or more may not be sufficient to eliminate the noise for certain waveband of the radios.)
- Do not install the air conditioner in the following locations:
 - (a) Where a mineral oil mist or oil spray or vapour is generated, for example, in a kitchen.
Plastic parts may be deteriorated and damaged, or result in water leakage.

- (b) Where corrosive gas (such as sulfurous acid gas) is produced. Corroding copper pipes or soldered parts may result in refrigerant leakage.
- (c) Near machinery emitting electromagnetic waves.
Electromagnetic waves may disturb the operation of the control system and cause the unit malfunction.
- (d) Where flammable gas leaks, where carbon fiber or ignitable dust floats, or where volatile flammables such as gasoline or thinner are placed.
Operating the unit in such conditions can cause a fire.
 - Do not use the air conditioner at the place where explosion may occur.
 - Do not touch the fins of heat exchanger. Improper touch may result in damage and injury.
 - Pay special caution to transportation of the unit.
PP packing belts are used for certain products. Do not lift the PP packing belts to transport as it's dangerous.
 - For the sake of security, discard the packing material. The packing material such as nails and woods may result in puncture wound or other dangers.
Tear and discard the plastic bag to prevent the children from suffocating when playing with the plastic bags.
 - Do not shut down the power supply immediately after the operation stops.
Wait at least 5 minutes before shutting down the power supply.
Failure to do so may result in water leakage and other malfunctions.
 - Depending on the setting conditions, different products may lead to electromagnetic interference.
In this case, keep proper distance away from the products.
 - Disposal requirements
Dismantling of the unit, treatment of the refrigerant, of oil and of other parts must be done in accordance with relevant local and national legislation.

Special notice product

- The refrigerant R32 requires that strict precautions be observed for keeping the system clean, dry and tightly sealed.

Clean and dry

Strict measures must be taken to keep impurities (including SUNISO oil and other mineral oils as well as moisture) out of the system.

Tightly sealed

R32A contains no chlorine, does not destroy the ozone layer and so does not reduce the earth's protection against harmful ultraviolet radiation. R32 will contribute only slightly to the greenhouse effect if released into the atmosphere .

See the catalogue for indoor unit models that can be connected. (Normal operation is not possible when connecting units that are originally designed for other refrigerants.)

Perform installation work in accordance with national standards.

2. Before installation

Do not and never discard any required accessories until the installation is completed!

1. Determine the move-in route of the air conditioner.
2. Do not remove the packing until carrying the unit to the installation locations. If the packing has to be removed, use a soft sling or put a protective plate under sling to lift the unit up and prevent the unit from being damaged or scratched.

No matter during or after unsealing, grasp the hanger bracket when carrying the air conditioner. Do not put any stress to the refrigerant piping, drain piping or plastic parts.

Check the refrigerant is R32 before installing the air conditioner.

For installing the outdoor unit, refer to the installation manual included with MFG QR code in the indoor unit.





- Do not install or use the air conditioner in the following locations:
 - Where the mineral oil, oil fume or spray is full of, for example, a kitchen. (Plastic parts may be aged and lead to unit's falling or water leakage finally.)
 - Where there is corrosive gas, such as sulfuric acid gas. (Copper pipes or soldered parts may be corroded and result in refrigerant leakage finally.)
 - Where there is flammable gas or volatile flammables such as gasoline or thinner is used. (Gases around the air conditioner may result in fire.)
 - Where there is machinery emitting electromagnetic waves. (Controlling system may not work.)
 - Where the content of the salt in the air is high, for example, on the coast, or where there is large voltage fluctuation, such as in the factory.
- Besides, it is also not suitable for vehicles or ships.
- This series air conditioner (including the indoor unit and outdoor unit) is suitable for household, business and light industry.

2-1. Caution





- Carefully read this manual before installing the indoor unit.
- Always ask the dealer or specialized personnel to carry out the installation work. Improper installation may result in water leakage, electric shocks or fire hazards.
- Only use the accessory components and parts or the ones in conformity with the technical specifications. Disqualified components and parts may result in the unit falling, water leakage, electric shocks or fire hazards.
- Explain the users how to operate the air conditioner's each function properly and how to regulate the temperature. Ask them to operate personally while reading the operation part under this manual.



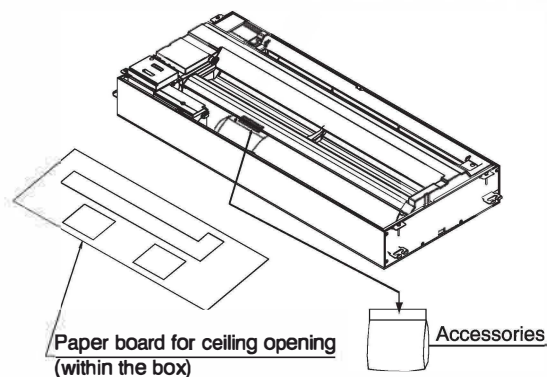

2-2. Accessories

Check if the following accessories are supplied with your air conditioner.

Description	① Drain hose	② Metal clip	③ Hanger bracket washers	④ Clamps
Quantity	1	1	8	6
Shape				



Description	⑤ Lifting screw mounting paper pattern	⑥ Screws (M5)	⑦ Washer fixing plate	Piping insulation material
Quantity	1	4	1 set	1 for each
Shape	 Also used as packaging	 Mounting paper pattern screws		 ⑧ For gas side piping  ⑨ For liquid side piping

Description	Insulation material		
	Quantity	1 for each	
Shape	 ⑩ Large  ⑪ Medium-1  ⑫ Medium-2	 ⑬	(Others) • Paper board for ceiling opening

2-3. Optional accessories

- Please refer to catalogue of the indoor unit, when performing installation work or checking after completing installation, pay special caution to the following items.
- The optional decoration panel and wireless remote controller receiver kit are required for this indoor unit. (Refer to Table 1,2) (However, the remote controller is not required for the slave unit of a simultaneous operation system.) (if wireless remote controller is not required then receiver kit no need.)
- Check that the decoration panel is prepared. (For the installation of the decoration panel, refer to the installation manual attached to the decoration panel.)

Table 1

Remote Controller		
Wired type		BRC1E63
Wireless type	Remote	BRC91A157
	Receiver Kit	BRC63AV

Note 

- These are two type of remote controller: wired and wireless. select a remote controller from **Table 1** according to the customer request and install in an appropriate place.

Table 2

Single Flow Cassette External Accessories			
Unit Model	Name of Accessories	Model No.	Remarks
FKAQ50AV16	Decoration Panel	BYKQ63AHW	Base Color: Dark Grey Surface Color: White
		BYKQ63AHS	Base Color: Dark Grey Surface Color: Silver
		BYKQ63AW	Base Color: White
			Surface Color: White
	Receiver Kit	BRC63AV	

a. Main check items after completing installation.



Check items	Results may be resulted in by improper installation	Signature after checking
Are the indoor and outdoor units installed reliably?	Unit's falling, vibrating or producing abnormal noise.	
Has the installation work of outdoor unit been completed?	The unit doesn't operate normally or with parts burnt out.	
is the gas leak inspection performed?	Insufficient cool air or hot air.	
Is the unit insulated completely? (Refrigerant piping, drain piping and air duct)	Condensed water dripping.	
Is the drainage proper?	Water leakage.	
Is the power voltage consistent with the specified voltage on the nameplate of the unit?	The unit doesn't operate normally or with parts burnt out.	
Are the wiring and piping connected properly?	The unit doesn't operate normally or with parts burnt out.	
Is the unit earthed safely?	Due to leakage of current may result in electric shock and fire.	
Are the specified wires used?	The unit doesn't operate normally or with parts burnt out.	
Are the indoor and outdoor units suction inlet and air outlet blocked by any obstacles?	Insufficient cool air or hot air.	
Are the refrigerant piping length and refrigerant charging amount recorded?	The refrigerant charging amount is not clear.	
Are the binding screws loose?	Electric shocks or fire hazards.	
Are the indoor unit and panel secured tightly?	Water leakage; condensed water dripping; producing abnormal noise.	
Are the panel and ceiling matched mutually according to this operation and installation manual?	Unit's panel falling off, vibrating, producing abnormal noise.	

Refer to the chapter of "safety precautions" simultaneously.

b. Main hand-over check items

Check items	Signature after checking
Are the electrical component box cover, air filter and intake flap installed?	
Are the use methods explained to the users based on the operation part under this manual?	
Are the manuals of the field-supply products handed over to the users, if there are?	

c. Commentary key points about the application methods

Contents marked with  Warning and  Caution in the operation manual emphasize the matter that failure to follow the normal unit operation methods may result in personal injury and property damage. It is necessary to explain the contents of the precautions to the users clearly and ask them to read the operation manual.

3. SELECTING INSTALLATION SITE

 CAUTION

- Be sure to grasp the hanger bracket when carrying the air conditioner with the package being opened or already opened. Do not put any stress to other parts especially the refrigerant piping, drain piping and flange.
- If temperature within the ceiling interlayer may exceed 30°C and the humidity over HR80%, thicken the insulation material of the unit body. Adopt glass wool or EPE (thickness at least 10mm and able to be gathered in the ceiling opening) as the insulation material.

(1) Select the installation location that meets the following conditions and get approval of the customer.

- Where the cool and warm air spreads evenly in the room. Where there is no obstacles in the air passage.
- Where drainage can be ensured.
- Where the ceiling lower surface is not inclined.
- Where there is sufficient strength to withstand the mass of the indoor unit (if the strength is insufficient, the indoor unit may vibrate and get in contact with the ceiling and generate unpleasant chattering noise).
- Where a space sufficient for installation and service can be ensured. (**Refer to Figures 1 and 2**)
- Where the piping length between the indoor and the outdoor units is ensured within the allowable length. (Refer to the installation manual.)
- Where there is no risk of flammable gas leak. (Refer to the installation manual of outdoor unit.)

Note 

- Install the indoor unit, outdoor unit, power wiring and transmission wiring at least 1m away from televisions and radios to prevent image interference and noise. (Depending on the radio waves, a distance of 1m may not be sufficient to eliminate the interference in some instances.)

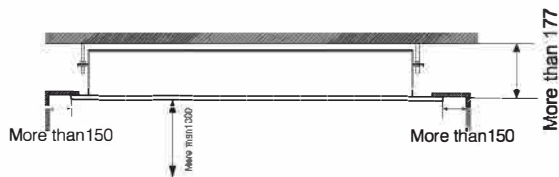

Figure 1

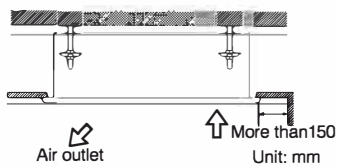

Figure 2

- (2) Perform installation with a lifting screw. Study if the ceiling is strong enough to hold the weight of the indoor unit. If the ceiling is not strong enough, reinforce the ceiling in advance.
(Refer to the spacing marked on the packaging box and check if it is necessary to reinforce.)

(3) Ceiling height

The indoor unit can be mounted to the ceiling with height not exceeding 3 m. However, if the ceiling height exceeds 2.7m, make the onsite settings using the remote controller. Refer to the chapter of "12. Field settings and test run".

4. Preparations before installation

- (1) Determine the relative positions of the ceiling opening, units and lifting screw. (Unit [mm])

[When mounting by matching with panel] [Unit: mm]

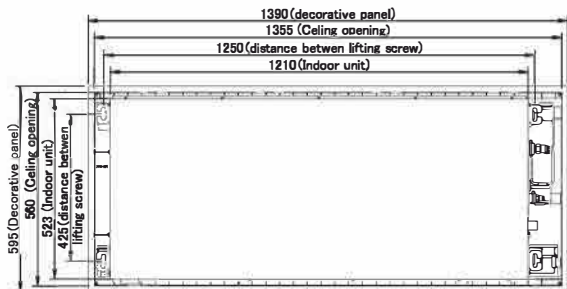

Figure 3

[Refer to the following figure]

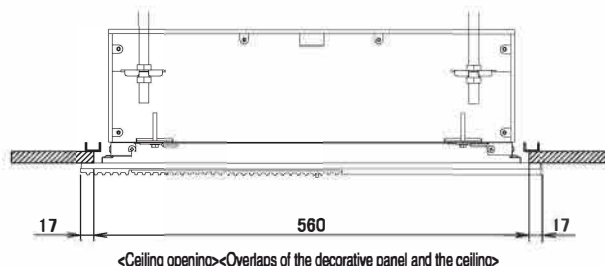

Figure 4

- (2) If necessary, punching through the opening needed for installation on the ceiling. (For locations already had the ceiling)

- For dimensions of the ceiling opening, refer to the paper board for ceiling opening (within the bottom box).
- Prepare all the pipes (refrigerant piping and drain piping) and electric wires (remote controller wiring, indoor and outdoor units' connection wiring and power wiring) to be connected to the indoor units before installation, so that they can be connected to the indoor units immediately after completing installation.
- After punching through the ceiling opening, in order to keep the ceiling flat and prevent it from vibrating, it may be necessary to reinforce the ceiling bracket. Consult your builder for details.

- (3) Install the suspension screw (use M8 or M10 bolts)

- In order to withstand the weight of the units, use foundation bolts for locations already having had the ceiling and embedded anchor bolts, buried anchor bolts or other field-supply parts for the newly-mounted ceiling. Before continuing installation, adjust the clearance between the lifting screw and the ceiling to 50-80mm.

[Installation example]

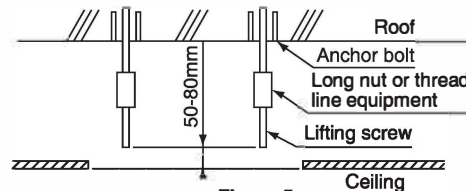

Figure 5

Note) All the above parts are supplied at the installation site.

5. Indoor unit installation

Be sure to use only the specified parts for installation work. installation procedure for locations with newly mounted ceiling:

- (1)-> (2) -> (3) -> (4)-> (5)

Installation procedure for locations with existing ceiling: (1)-> (3) -> (4) -> (5)

- (1) Temporarily install the indoor units

- Attach the hanger bracket to the lifting screw. Be sure to secure the hanger bracket firmly at the upper and lower ends using the nuts and hanger washers③. The washer fixing plate⑦ can prevent the hanger washer③ from slipping off.

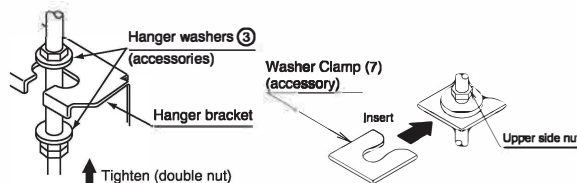

[Secure the hanger bracket]

Figure 6

[Washer clamp(7) fixing method]

Figure 7

- (2) For dimensions of the ceiling opening, refer to the paper board for ceiling opening. Consult your builder or carpenter for details.

- Center of the ceiling opening is marked on the paper board for ceiling opening. Center of the units is in line with that of the ceiling opening.
- Fix the paper board for ceiling opening to the units using 4 screws ⑥. In this case, make the hole on the unit's hanger bracket corresponded to the mounting hole on the paper board for ceiling opening.
- Relative positions of the main unit and ceiling are marked on the paper board for ceiling opening. Adjust the height of the unit body accordingly.

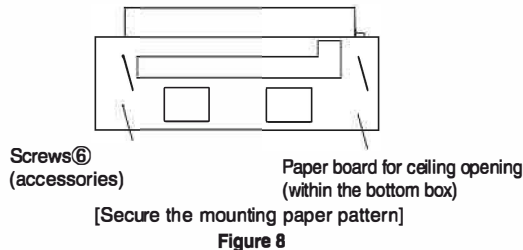

(3) Adjust the levelness of the air conditioner.

The indoor unit is equipped with a built-in drain pump and float switch. Adjust the levelness using a level meter or polyethylene pipe filled with water.

Levelness of unit should not exceed 0.5 deg down at opposite side of drain pump.

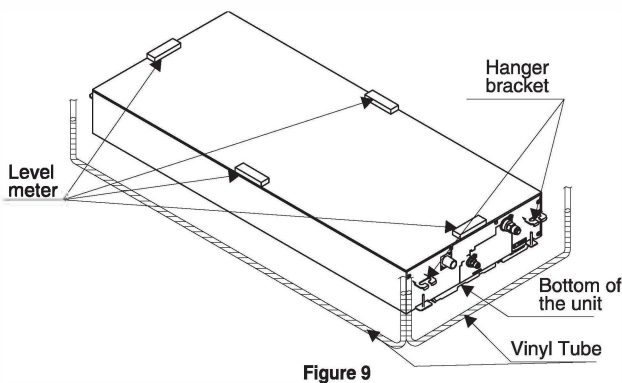

Caution

If the unit tilts to the opposite flow direction of the condensed water, the float switch will not operate normally, which will cause water leakage.

Pull out the inserted washer fixing plate ⑦ which is used to prevent the washer from slipping off and tighten the upper nut. Remove the paper board for ceiling opening.

6. Decorative panel installation

<Refer to panel operation & installation manual for detailed decorative panel installation.>

7. Refrigerant piping installation

<For installing the refrigerant piping of the outdoor unit, refer to the installation manual included with MFG label QR code in indoor unit.>

<Insulate both gas side piping and liquid side piping effectively. Otherwise, it may cause water leakage. Use the insulation material which can withstand high temperature of 120 °C or more. Besides, reinforce the insulation of the refrigerant piping in accordance with the installation environment. If not reinforced, condensation could form on the surface of the insulation material.>

<Be sure to check the refrigerant is R32 before performing refrigerant piping installation. Adopting other refrigerants may result in the abnormal operation of the unit.>

Caution

- Be sure to use the special pipe cutters and flaring tools for R32.
- When connecting the flaring, only coat the refrigerant oil (ester or ether oil) to the inner side of the flaring.
- Always use the flaring nut included with the unit. (Do not use other flaring nuts such as 1-type flaring nut. Using other flaring nuts may lead to refrigerant leakage.)
- To prevent entry of any dirt, dust or moisture into the piping, adjust the piping through pinching or sealing methods.
- Be sure to use the specified refrigerant during refrigerant circulation and prevent the air from contaminating the refrigerant.
- If refrigerant leaks during installation work, be sure to ventilate the rooms.

(1) Connect the piping.

- The outdoor unit have been charged with the refrigerant.
- Aim the refrigerant piping connector section at the center of the flaring part. Turn 3~4 circles with your hands and tighten with the specified tightening torque.
- To prevent the flaring part from cracking or leaking gas, tighten with a torque wrench. (Refer to Figure 10)
- To prevent gas leakage, coat the refrigerant oil (ester or ether oil) to the inner side of the flaring part. (Refer to Figure 11)
- Secure the flaring nut to the main unit. (To prevent the flaring nut form aging and cracking)
- Refer to Table 3 for the flaring size and tightening torque.

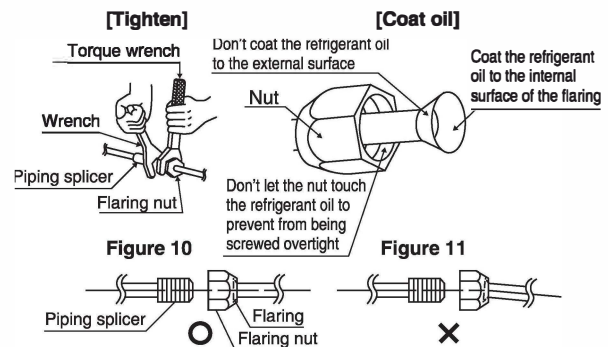

Note: Be sure to align the center of the refrigerant piping connector part with the ones of the flaring part and flaring nut. Failure to do so may result in piping breakage or gas leakage.

Table 3

PIPING SIZE (mm)	TIGHTENING TORQUE	A DIMENSIONS FOR PROCESSING FLARES (mm)	FLARE SHAPE
Ø6.4	15.7 ± 1.5 N·m	8.9 ± 0.2	
Ø9.5	36.3 ± 3.6 N·m	13.0 ± 0.2	
Ø12.7	54.9 ± 5.4 N·m	16.4 ± 0.2	
Ø15.9	68.6 ± 6.8 N·m	19.5 ± 0.2	
Ø19.1	108.0 ± 10.8 N·m	23.8 ± 0.2	

Caution

Screwing overtight will damage the flaring and result in refrigerant leakage. Please note that do not apply the oil to other parts excluding the flaring nut. Applying the oil to resin part, etc. will result in damage.

- If there is no torque wrench, refer to table 4.

It is not recommended and only use in emergency. It's necessary to use the torque wrench to install the units. If you have to install the units but without the torque wrench, then perform installation based on following approach. After completing installation work, be sure to check for gas leakage. When tightening the flaring nut with a wrench, the tightening torque will suddenly increase at certain position. In this case, continue rotate the flaring nut to the following angles from this position.

Table 4

PIPING SIZE (mm)	FURTHER TIGHTENING ANGLE	RECOMMENDED ARM LENGTH OF TOOL
Ø6.4	60 to 90 degrees	About 150 mm
Ø9.5	60 to 90 degrees	About 200 mm
Ø12.7	30 to 60 degrees	About 250 mm
Ø15.9	30 to 60 degrees	About 300 mm
Ø19.1	20 to 35 degrees	About 450 mm

Insulation of the liquid side piping

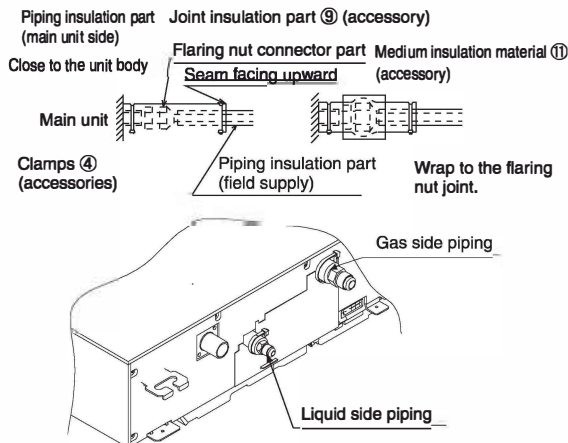

Insulation of the gas side piping

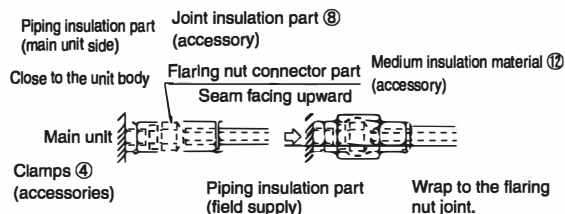

Figure 12

- (2) After piping connection is finished, check if gas leaks.
- (3) After checking that there is no gas leakage, insulate the piping connector part properly with insulation material. (Refer to Figure 12)

- When performing insulation, attach the included joint in insulation parts (8) and (9) to the liquid side piping and gas side piping. In addition, make the seams of the joint insulation parts (8) and (9) face upward. (Pinch both ends with the clamps (4).)
- For the liquid side piping and gas side piping, wrap the medium insulation material (11) and (12) to the joint insulation parts (8) and (9). (Flaring nut part) For piping connected locally, wrap the insulation material till the piping connections. The naked piping may result in condensation and burns.
- Before brazing the refrigerant piping, perform nitrogen replacement first, or charging nitrogen into the refrigerant piping (Caution 1) during brazing (Caution 2), then connect with the indoor unit using the flaring. (Refer to Figure 13)

Caution

1. When charging nitrogen into the piping for brazing, set the pressure to 0.02 MPa (0.2kgf/cm²) using pressure-reducing valve (as a slight breeze on your cheek).
2. Do not use flux when brazing the refrigerant piping connector part. Use the phosphor copper electrode which does not require flux (BCuP-2:JIS Z 3264 / BCu93P-710 / 795:ISO 3677). (If the chlorine based flux is used, it will cause pipe corrosion; if the flux contains fluorine, it will damage the ester or ether oil and further adversely affect the refrigerant piping system.)
3. Make sure to use the following refrigerant piping Material: Jointless phosphor-deoxidized copper pipe
4. Do not use any anti-oxidants when brazing the piping. The residual anti-oxidants may clog the piping and result in malfunction of the parts.

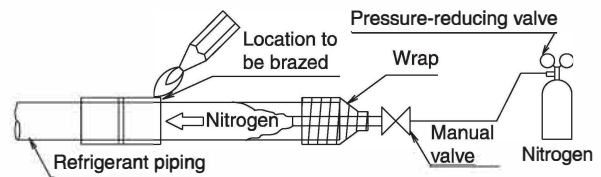
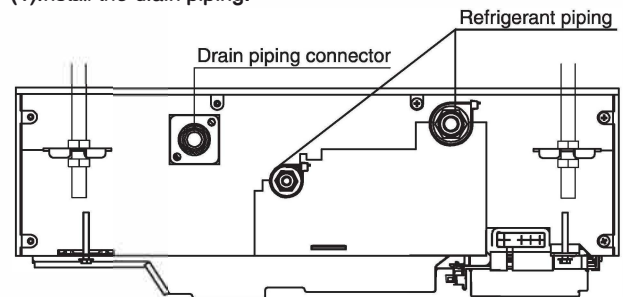

Figure 13

8. Drain piping installation

- (1) Install the drain piping.



- Ensure proper drainage of the drain piping installed.

- Diameter of the drain piping must be equal to or greater than that of the connecting pipes. (Poly Vinyl Tube ; piping size: 25mm; outer diameter: 32mm) (Excluding the lifting pipes)
- To prevent the air embolism from being formed , shorten the drain piping as much as possible and slant it downward. The gradient should be 1/100 or more. (Refer to Figure 14)

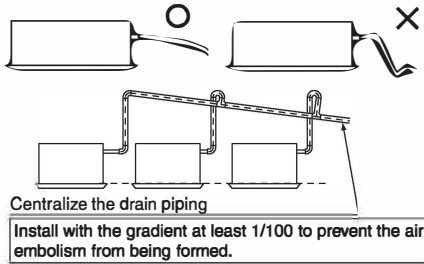

Figure 14

Caution

If drain stagnates in the drain piping, the piping may be clogged.

- To prevent the piping from bending and sagging down, secure them every 1-1.5m using slings.
- Use the accessory drain hose ① and metal clip ②. The drain hose ① should be inserted till the end of the drain socket and secured firmly to the marker at the front end of the hose using the metal clip ②. Tighten the metal clip ② till the raised distance of the screw head less than 4mm. (Refer to Figures 15 and 16)
- The following two parts must be insulated to prevent condensation and dripping.
 - Indoor drain hose
 - Drain socket

As shown in the figure below, insulate the metal clip and drain hose CD with the large insulation material (shipped with the unit accessory). tightening torque $1.5 \pm 0.1 \text{ N.m}$ (Refer to Figure 16)

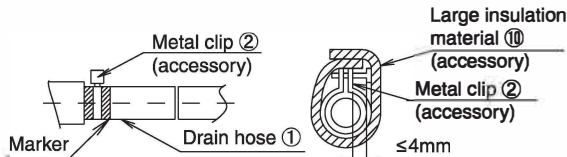

Figure 15

Figure 16

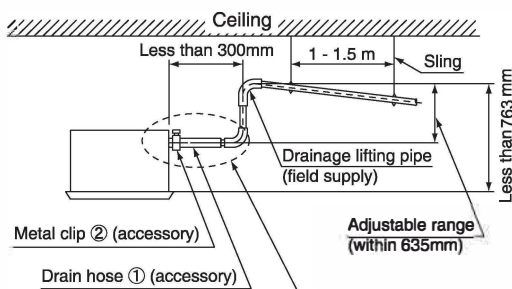
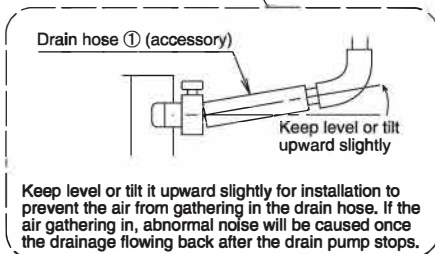

Figure 17



<Precautions for installing drainage lifting pipe>

- Make sure the height of the drainage lifting pipe is within 635mm.
- Keep the drainage lifting pipe vertical and maximum 300mm away from the air conditioner. (Refer to Figure 17)

Note

Drain piping connection

- Do not connect it directly to the sewage pipes with ammonia odour. Ammonia in the sewage pipes may enter the indoor unit body through the drain piping and corrode the heat exchanger.
- Do not twist or bend the drain hose CD, also do not apply excessive force. Failure to do so will result in water leakage.
- To use the converging drain piping, connect in accordance with Figure 14.
- Select the converging drain piping with proper size in accordance with the capacity of the unit to be connected.

(2) Check if the drainage is proper after completing installation.

After completing wiring installation

To prevent water from gathering in the electrical components such as the drain pump, add about 1000CC water slowly from the air outlet. Check the drainage condition in accordance with the "12. Field settings and test run" while performing cooling operation.

During wiring installation

Caution

- All electrical work (including grounding engineering) must be carried out by the electricians with professional qualifications.
- If the electricians are absent from the site, check the drainage using steps 3 to 6 after the system test run is stopped.

1. Remove the electrical component box cover and connect the single-phase 50Hz, 220-240V power circuit to the L and N of the power terminal block.
2. Check if the electrical component box cover has been fastened completely before turning on the power supply.

(Unit mm)

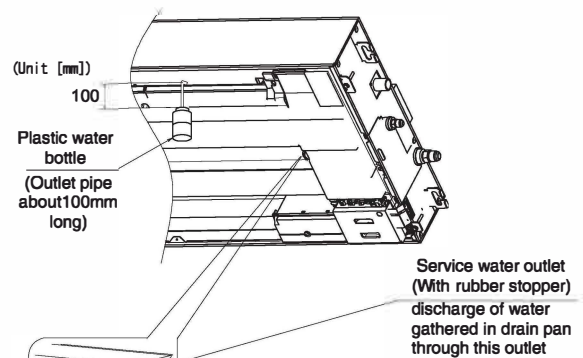

Figure 18 [Water adding method]

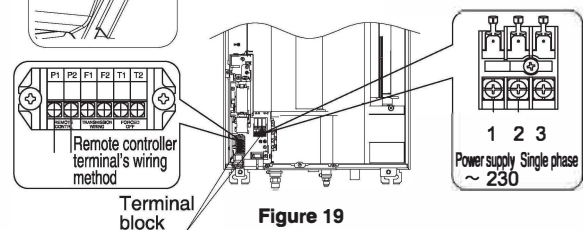

Figure 19

- To prevent water from gathering in the electrical components such as the drain pump, add about 1000CC water slowly from the air outlet.
- Turn on the power supply to start the drain pump. It is possible to check the drainage condition through the transparent part of the drain socket. (The drain pump will stop automatically after 10 minutes.)

⚠ Caution

Be careful that the fan is also rotating now.
Do not touch the drain pump to prevent electric shocks.

- After completing drainage inspection (Figures 18 and 19), shut off the power supply and remove the power wiring.
- Attach the electrical component box cover as original.

9. Electrical wiring work

9-1. Overview

- Always shut down the power supply before performing any electrical work.
- All locally-purchased parts & materials and electrical work must comply with local codes.
- Use copper conductors only.
- When performing the electrical wiring work, refer to the "wiring diagram" labeled to inside casing near EL box.
- For details of the remote controller's wiring, refer to the "Remote controller installation manual" included with it.
- All wiring work must be carried out by the qualified electricians.
- The system includes several indoor units. Name each indoor unit after A unit, B unit. and make sure that the numbers of the wires connected from the terminal blocks are consist with that of the outdoor unit and BS unit. Incorrect wire and piping connection between the indoor unit and outdoor unit will result in the air conditioning system abnormally operating. To prevent error occurring, perform wiring by referring to [Wiring example].
- Be sure to install a line breaker or earth leakage circuit breaker near the power supply.
- Do not connect the earth wire to the gas pipes, water pipes, lightning rods or telephone earth wires.
- Gas pipes: gas leakage can cause explosion or fire.
- Water pipes: cannot be grounded if hard polyethylene pipes are used.
- Telephone earth wires and lightning rods: the ground potential when struck by lightning gets extremely high.
- To prevent short circuit of the power wiring, terminals with insulation sleeves must be used.
- Do not turn on the power supply (line breaker or earth leakage circuit breaker) before completing all electrical work.

9—2. Specifications of the standard electric wires Power wiring, etc.

Model	Power supply wiring		
	Field fuses	Wiring	Size
FKCF71CRV16	20A	H05W-U3G (Note 4,5)	2.5mm ² (Note 7)

Note 

- It is possible to have the overcurrent circuit breaker instead of the fuse.

- If the electric wires are located in the places where they are easy to be touched by personnel, mount the earth leakage circuit breaker to prevent electric shocks.
- Use the earth leakage circuit breaker compatible with the appliances for grounding over-current protection and short circuit protection. If the ground protection special appliance is mounted to the earth leakage circuit breaker, be sure to mount a line breaker together.
- Shows only in case of protected piping. Use H07RN-F in case of no protection.
- Supply cords shall not be lighter than polychloroprene sheathed flexible cord (code designation 60245 IEC 57) Vinyl cord with sheath or cable (Insulated thickness : 1 mm or more)
- Wiring size and length must comply with local codes or IEC 60335-1 (Table 11)

The lengths of remote controller wiring and transmission wirings are as follows:

- | | |
|---|----------------------------|
| (1) Remote controller wiring
(indoor unit - remote controller) | Max. 500 m |
| (2) Transmission wirings | Total wiring length 2000 m |
| • Outdoor unit - Indoor unit. | Max. 1000 m |
| • Outdoor unit - BS unit | Max. 1000 m |
| • BS unit - Indoor unit | Max. 1000 m |
| • Indoor unit - Indoor unit | Max. 1000 m |

9-3. Electrical characteristics

Model		Power Supply				IFM		
INDOOR	OUTDOOR	HZ Voltage		Voltage range	MCA	MFA	KW	FLA
FKCF71CRV16	RZFC71CRV16	50	230	Max. 253V Min. 207V	12	20	0.06	0.6

MCA: Minimum circuit current (A)
MFA: Maximum fuse current (A)
KW: Fan motor rated output power (kW)
FLA: Full-load current (A)

10. Wiring example and how to set the remote controller

10-1 How to connect wiring (See Fig. 20)

- Power supply wiring**
Remove the control box lid (1) and connect the wires to the power supply terminal block inside (1, 2, 3) and connect the ground wire to the grounding terminal. While doing this, pull the wires inside through the hole in the casing and clamp the wires along with other wires using a clamp as indicated in the figure.
- Remote controller wiring**
Remove the control box lid (1) and pull the wires inside through the hole in the casing and connect to the terminal block for remote controller wiring (P1, P2). Securely fix the wiring using a clamp as indicated in the figure.
- After connection**
Attach the small sealing (supplied with the unit) around the cables to prevent infiltrating of water from the outside into the unit. If two or more cables are used, divide the small sealing into the required number of pieces and wrap them around all the cables.
- Attach the control box lid.

Precautions

- (1) Observe the notes mentioned below when wiring to the power supply terminal block.
 - Use a round crimp-style terminal for insulation sleeve for connection to the terminal block for wiring the units. When none are available, follow the instructions below.

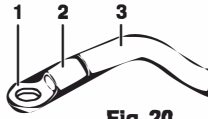

Fig. 20

- 1 Round crimp-style terminal
- 2 Attach insulation sleeve
- 3 Wiring

- Do not connect wires of different gauge to the same power supply terminal. (Looseness in the connection may cause overheating.)
- When clamping wiring, use the clamps (delivered with the unit) to prevent outside pressure being exerted on the wiring connections. Tie up firmly. When doing the wiring, make sure the wiring is neat and does not cause the control box to stick up. Close the cover firmly.
- When connecting wires of the same gauge, connect them according to the figure



Fig. 21

Use the specified electric wire. Connect the wire securely to the terminal. Lock the wire down without applying excessive force to the terminal. Use torques according to the table below.

Wiring	Screw size	Tightening torque (N · m)
Interconnection cable (indoor↔outdoor)	M4	1.3±0.1
User interface cable	M3.5	0.88±0.08

- When attaching the control box lid, make sure not to pinch any wires.
 - After all wiring connections are done, fill in any gaps in the casing wiring holes with putty or insulation material (field supply) thus to prevent small animals or dirt from entering the unit from outside and causing short circuits in the control box.
- (2) Keep total current of crossover wiring between indoor units less than 12 A. Branch the line outside the terminal block of the unit in accordance with electrical equipment standards, when using two power wiring of a gauge greater than 2 mm² (Ø1.6).

The branch must be sheathed in order to provide an equal or greater degree of insulation as power supply wiring itself.
 - (3) Do not connect wires of different gauge to the same grounding terminal. Looseness in the connection may deteriorate the protection.
 - (4) Remote controller wiring and unit transmission wiring should be located at least 50 mm away from power supply wiring. Not following this guideline may result in malfunction due to electrical noise.
 - (5) For the remote controller wiring, refer to the "Installation manual of the remote controller" supplied with the remote controller.

NOTE

The customer has the ability to select the remote controller thermistor.

- (6) Never connect the power supply wiring to the terminal block for transmission wiring. This mistake could damage the entire system.
- (7) Use only specified wires and tightly connect wires to the terminals. Be careful that wires do not place external stress on the terminals. Keep wiring in neat order so that they do not obstruct other equipment such as popping open the service cover. Make sure the cover closes tight. Incomplete connections could result in overheating, and in the worse case, electric shock or fire.

10-2 Wiring example



Be sure to install an earth leakage breaker to the outdoor unit. This is to avoid electric shocks or a fire.

For the wiring of outdoor units, refer to the installation manual attached to the outdoor units. Confirm the system type.

- **Pair type:**
 - 1 remote controller controls 1 indoor unit (standard system). (Refer to Fig. 22)
- **Group control:**
 - 1 remote controller controls up to 16 indoor units (All indoor units operate according to the remote controller). (Refer to Fig. 23)

Pair type

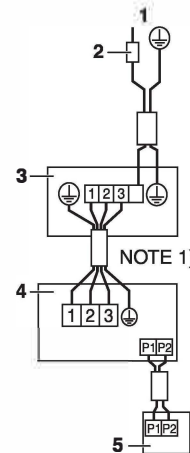

Fig. 22

- 1 Power supply
- 2 Earth leakage breaker
- 3 Outdoor unit
- 4 Indoor unit
- 5 Remote controller (Optional accessory)

NOTE

1. Terminal numbers of outdoor and indoor units must be matched.
 - 2-1. Connect the remote controller only to the master unit.
 - 2-2. The indoor temperature sensor is effective only for indoor units to which the remote controller is connected.
 - 2-3. The length of wiring between the indoor unit and the outdoor unit varies depending on the connected model, the number of connected units, and the maximum piping length. For details, refer to the technical documents.

Group control

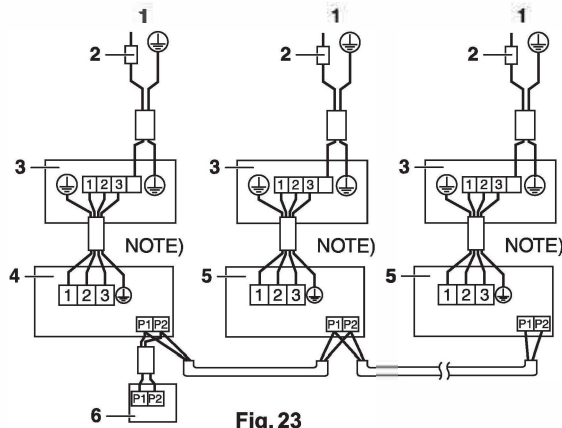

Fig. 23

- 1 Power supply
- 2 Earth leakage breaker
- 3 Outdoor unit
- 4 Indoor unit (Master)
- 5 Indoor unit
- 6 Group control remote controller (Optional accessory)

NOTE

- Terminal numbers of outdoor and indoor units must be matched.

When implementing group control

- When using as a pair unit, you may carry out simultaneous start/stop (group) control up to 16 units with the remote controller. (Refer to Fig. 24)
- In this case, all the indoor units in the group will operate in accordance with the group control remote controller.
- Select a remote controller which matches as many of the functions (airflow direction, etc.) in the group as possible.

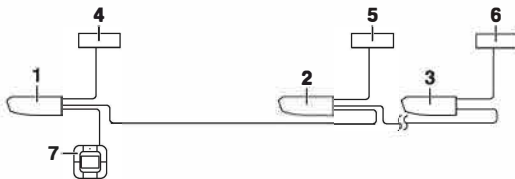

Fig. 24

- 1 Indoor unit 1
- 2 Indoor unit 2
- 3 Indoor unit 16
- 4 Outdoor unit 1
- 5 Outdoor unit 2
- 6 Outdoor unit 16
- 7 Group control remote controller

Wiring Method

- (1) Remove the control box lid. (Refer to "10. WIRING EXAMPLE AND HOW TO SET THE REMOTE CONTROLLER".)
- (2) Connect crossover wiring between the terminals (P1, P2) inside the control box for the remote controller. (There is no polarity.) (Refer to Fig. 24)

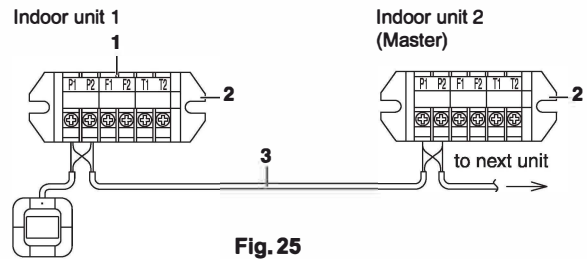

Fig. 25

- 1 Terminal for remote controller wiring (P1, P2)
- 2 Terminal block (X1M)
- 3 Crossover wiring

10-3 For control with 2 remote controllers (to control 1 indoor unit with 2 remote controllers)

- For control with 2 remote controllers, set one remote controller as Main and the other remote controller as Sub.

[Changeover method from Main to Sub and vice versa]

Refer to the installation manual attached to the remote controller.

[Wiring method]

- (1) Remove the control box lid.
- (2) Connect the wiring to the terminals for remote controller 2 (Sub) in the control box.

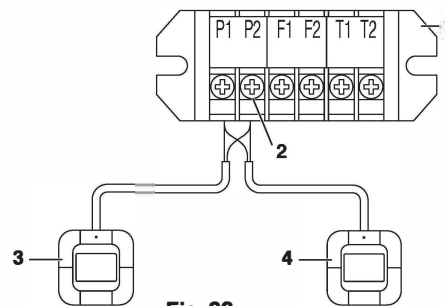

Fig. 26

- 1 Terminal block (X1M)
- 2 Terminal for remote controller wiring (P1, P2) (No polarity)
- 3 Remote controller 1 (Main)
- 4 Remote controller 2 (Sub)

CAUTION

- When using the group control and the 2 remote controllers control at the same time, connect the remote controller 2 (Sub) to the indoor unit at the end of the crossover wiring (the largest No.). (Refer to Fig. 26)

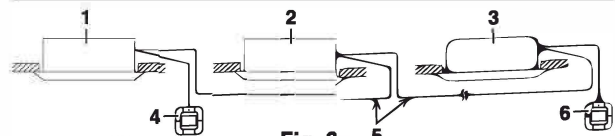

Fig. 27

- 1 Indoor unit 1
- 2 Indoor unit 2
- 3 Indoor unit largest No.
- 4 Remote controller 1 (Main)
- 5 Crossover wiring (Remote controller)
- 6 Remote controller 2 (Sub)

10-4 Computerized control (forced off and on/off operation)

- (1) Wire specifications and how to perform wiring
 - Connect the input from outside to terminals T1 and T2 of the terminal block (6P) for remote controller.

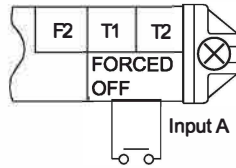

Fig. 28

Wire specification	Sheathed vinyl cord or cable (2 wire)
Gauge	0.75-1.25mm ²
Length	Max. 100m
External terminal	Contact that can ensure the minimum applicable load of 15V DC, 1 mA.

- (2) Actuation
 - The following table explains FORCED OFF and ON/OFF OPERATIONS in response to Input A.

FORCED OFF	ON/OFF OPERATION
Input "ON" stops operation (impossible by remote controllers).	Input OFF → ON turns ON unit.
Input "OFF" enables control by remote controller.	Input ON → OFF turns OFF unit.

- (3) How to select FORCED OFF and ON/OFF OPERATION
 - Turn the power on and then use the remote controller to select operation.
 - Set the remote controller to the field set mode. For details, refer to the "HOW TO SET IN THE FIELD", in the remote controller manual.
 - When in the field set mode, select mode No. 12, then set the first code (switch) No. to "1". Then set second code (position) No. to "01" for FORCED OFF and "02" for ON/OFF OPERATION. (FORCED OFF at factory set)

10-5 Centralized control

- For centralized control, it is necessary to designate the group No. For details, refer to the manual of each optional controllers for centralized control.

10-6 Panel wire connecting

- To connect with the panel's connecting wires, refer to the panel installation manual for detailed information.

11. Decorative panel installation for test run

To perform test run without installing the decorative panel, read the chapter "12. Field settings and test run" first. Refer to the installation manual included with the decorative panel.

After completing installation of the decorative panel, make sure there is no clearance between the units and the decorative panel.

12. Field settings and test run



- Check if all the installation and piping works for the air conditioner are completed.
- Check if the control box lids of the air conditioner are closed.

< FIELD SETTING >

<<After turn on the power supply, carry out field setting from the remote controller according to the installation state.>>

- Carry out setting at 3 places, "Mode No.", "FIRST CODE No." and "SECOND CODE No.". The settings shown by "□" in the table indicate those when shipped from the factory.
- The method of setting procedure and operation is shown in the installation manual attached to the remote controller. (Note) Though setting of "Mode No." is carried out as a group, if you intend to carry out individual setting by each indoor unit or confirmation after setting, carry out setting with the Mode No. shown in the parenthesis ().
- Ask your customer to keep the manual attached to the remote controller together with the operation manual.
- Do not carry out settings other than those shown in the table.

12-1 Setting when an optional accessory is attached

- For setting when attaching an optional accessory, refer to the installation manual attached to the optional accessory.

12-2 When using wired remote controller

- When using a wireless remote controller, it is necessary to set the wireless remote controller address. Refer to the installation manual attached to the wireless remote controller.

12-3 Setting fan speed during thermostat off

- Set the fan speed according to the using environment after consultation with your customer.
- When the fan speed is changed, explain the set fan speed to your customer.

Table 5

Setting		Mode No.	FIRST CODE	SECOND CODE
			No.	No.
Fan operates / stops during thermo OFF (Cooling)	Operates	11 (21)	2	1
	Stops			2
Fan speed during cooling thermostat OFF	(Extra low)	12 (22)	6	1
	Setting			2

12-4 Setting filter sign

- A message to inform the air filter cleaning time will be indicated on the remote controller.
- Set the SECOND CODE No. shown in the "Table 6" according to the amount of dust or pollution in the room.
- Though the indoor unit is equipped with the long life filter, it is necessary to periodically clean the filter to avoid clogging of the filter. Please also explain the set time to the customer.
- The periodical filter cleaning time can be shortened depending on the environment.

Table 6

Contamination	Hours until indication	Mode No.	FIRST CODE No.	SECOND CODE No.
Normal	Approx. 2500 hrs	10 (20)	0	01
More contaminated	Approx. 1250 hrs			02
With indication		3		01
No indication*				02

* Use "No indication" setting when cleaning indication is not necessary such as the case of periodical cleaning being carried out.

13. Test operation

Refer to the installation manual attached to the remote controller.

- Check that wiring work of the indoor unit and the outdoor unit is completed.
- Check that control box lid of the indoor unit and the outer panel and piping cover of the outdoor unit are closed.
- After refrigerant piping, drain piping and electric wiring are completed, clean the inside of the indoor unit and decoration panel.
- Perform the test operation according to following procedure.

(1) To protect the compressor, turn on the power to the outdoor unit at least 6 hours prior to test operation.

(2) Confirm that stop valves of both liquid side and gas side are opened.



Make sure that outer panel and piping cover are closed before operation (danger of electric shock).

- After air purge by vacuum pump, refrigerant pressure may not rise even though the stop valve is opened. The reason is that refrigerant system of the outdoor unit is blocked by electric expansion valve or the like. Operation is no problem.



- If the interior finish work is not completed when the test operation is finished, for protection of the air conditioner ask the customer not to operate the air conditioner until the interior finish work is completed. If the air conditioner is operated, the inside of the indoor units may be polluted by substances generated from the coating and adhesives used for the interior finish work and cause water splash and leakage.

13-1 Malfunction code list

- For places where the malfunction code is left blank, the "ⓘ" indication is not displayed. Though the system continues operating, be sure to inspect the system and make repairs as necessary.
- Depending on the type of indoor or outdoor unit, the Malfunction code may or may not be displayed.

Code	Malfunction/Remarks
A0	Safety device operates
A1	Indoor unit's PC board faulty
A3	Drain water level abnormal
A6	Indoor fan motor overloaded, overcurrent or locked
A8	Fan PCB power supply error
AF	Humidifier faulty
AH	Air cleaner faulty
	Only the air cleaner does not function
AJ	Type set improper
	Capacity data is wrongly preset. Or there is nothing programmed in the data hold IC
C1	Indoor PCB (Master) - indoor PCB (Slave) transmission defect
C4	Sensor (R2T) for heat exchanger temperature is fault
C5	Sensor (R3T) for heat exchanger temperature is fault
C6	Fan PCB setting defect
C9	Sensor for suction air temperature is fault
CC	Humidity sensor abnormal
CE	Human detection / floor temperature sensor error
CJ	Sensor for remote controller is fault
	The remote controller thermistor does not function, but the system thermo run is possible.
E0	Action of safety device (outdoor unit)
E1	Outdoor unit's PC board faulty
E3	High pressure abnormal (outdoor unit)
E4	Low pressure abnormal (outdoor unit)
E5	Compressor motor lock malfunction
E7	Outdoor fan motor lock malfunction
	Outdoor fan instantaneous overcurrent malfunction
E9	Electronic expansion valve faulty (outdoor unit)
EA	Error from defect of change 4 way valve (outdoor)
F3	Discharge pipe temperature abnormal (outdoor unit)
H3	High pressure switch faulty (outdoor unit)
H4	Low pressure switch faulty (outdoor unit)

H7	Outdoor motor position signal malfunction
H9	Outdoor air thermistor faulty (outdoor unit)
	Equipment operation in response to errors will vary according to model
JA	Discharge pipe pressure sensor faulty (outdoor unit)
JC	Suction pipe pressure sensor faulty (outdoor unit)
J1	Pressure sensor system error (batch) (outdoor unit)
J2	Power sensor system error (outdoor unit)
J3	Discharge pipe thermistor faulty (outdoor unit)
	Equipment operation in response to errors will vary according to model
J5	Suction pipe thermistor faulty (outdoor unit)
J6	Heat exchanger thermistor faulty (outdoor unit)
	Equipment operation in response to errors will vary according to model
J7	Heat exchanger thermistor faulty (outdoor unit)
	Equipment operation in response to errors will vary according to model
J8	Liquid pipe temperature sensor system error (outdoor unit)
J9	Intake temperature sensor error (outdoor unit)
L1	Inverter system error (outdoor unit)
L3	Reactor thermistor error (outdoor)
L4	Overheated heat-radiating fin (outdoor unit)
	Inverter cooling defect
L5	Instantaneous overcurrent (outdoor unit)
	Possible earth fault or short circuit in the compressor motor
L8	Electric thermal (outdoor unit)
	Possible electrical overload in the compressor or cut line in the compressor motor
L9	Stall prevention (outdoor unit)
	Compressor possibly locked
LC	Transmission malfunction between the outdoor control unit's inverters (outdoor unit)
P1	Open-phase (outdoor unit)
P3	P-board temperature sensor malfunction (outdoor unit)
P4	Heat-radiating fin temperature sensor malfunction (outdoor unit)
P6	DC output current error (outdoor)

PJ	Type set improper (outdoor unit)
	Capacity data is wrongly preset. Or there is nothing programmed in the data hold IC
U0	Suction pipe temperature abnormal
U1	Reverse phase
	Reverse two phase of the L1, L2 and L3 leads
U2	Power source voltage malfunction (outdoor unit)
	Includes the defect in 52C
U4 UF	Transmission error (indoor unit-outdoor unit)
	Wrong wiring between indoor and outdoor units or malfunction of the PC board mounted on the indoor and the outdoor units
U5	Transmission error (indoor unit-remote controller)
	Transmission is improper between the indoor unit and the remote controller
U8	Malfunction in transmission between main and sub remote controller (Malfunction in sub remote controller)
UA	Miss setting for multi system
	Setting is wrong for selector switch of multi-system. (see switch SS2 on the main unit's PC board)
UC	Central control address overlapping
UE	Transmission defect (indoor - centralizing)
UJ	Peripheral equipment transmission fault

DAIKIN

Split System Air Conditioner

INSTALLATION MANUAL <FOR OUTDOOR UNIT>

READ THESE INSTRUCTIONS CAREFULLY BEFORE INSTALLATION.

NEW REFRIGERANT (R32) SERIES

RZFC71CRV16

Note : ⓘ Read the precautions in this manual carefully before operating the unit.

⚠ This appliance is filled with R32.

CONTENTS

※ SAFETY PRECAUTIONS.....	16
1. BEFORE INSTALLATION.....	18
2. SELECTING INSTALLATION SITE.....	18
3. INSTALLATION SERVICE SPACE.....	20
4. PRECAUTIONS ON INSTALLATION.....	23
5. REFRIGERANT PIPING WORK.....	23
6. AIRTIGHTNESS TEST AND AIR-PURGE.....	26
7. CHARGING REFRIGERANT.....	27
8. ELECTRICAL WIRING WORK.....	28
9. CHECK ITEMS BEFORE TEST OPERATION AND FIELD SETTINGS.....	31
10. TEST OPERATION.....	32
11. CAUTION.....	33
12. HOW TO RE-USE THE EXISTING PIPING.....	34
13. REFRIGERANT RECOVERY.....	35
14. UNPACKING & PACKING INSTRUCTION OF OUTDOOR UNIT	36



WARNING THERE IS A RISK OF EXPLOSION OR FIRE

- Do not mix air in the refrigerating cycle during pump down operation.
- Do not use oxygen for air tight test.
- Do not use refrigerant other than the specified one or flammable material (e.g. propane) in the refrigerant cycle. They may cause over pressure in the refrigerating cycle and result in explosion, fire or injury. Our company assumes no responsibility for failure or malfunction caused by filling or mixing of anything other than the specified refrigerant.



CAUTION ABOUT ISOLATING RESISTANCE OF COMPRESSOR

If refrigerant accumulates in the compressor after completing installation, the insulation resistance can drop, but if it at least 1 MΩ, then the unit will not break down.

- Connect the power supply to the unit and after 6 hours check if the insulation resistance of the compressor rises. (Energize and heat the compressor to vaporize the refrigerant accumulated in the compressor.)
- If the earth leakage breaker actuates, check if the earth leakage breaker is equipped with a device to cope with high harmonics. To prevent wrong actuation of the earth leakage breaker due to the inverter, make sure to adopt an earth leakage breaker equipped with a device to cope with high harmonics.



- Please make sure to confirm that R32 (new refrigerant) is used in installation work in advance.
(It may not operate normally, if refrigerant type is different.)
- The refrigerant R32 requires that strict precautions be observed for keeping the system clean, dry and tightly sealed.
 - Clean and dry
Strict measures must be taken to keep impurities (Including SUNISO oil and other mineral oils as well as moisture) out of the system.
 - Tightly sealed
R32 contains no chlorine, does not destroy the ozone layer and so does not reduce the earth's protection against harmful ultraviolet radiation. R32 will contribute only slightly to the greenhouse effect if released into the atmosphere. Therefore, sealing tightness is particularly important in installation.
Carefully read the chapter **5 REFRIGERANT PIPING WORK** and strictly observe the correct procedures.
- The design pressure of this unit : High/Low pressure area are shown in the right table.
The refrigerant piping is a high pressure area,
Use the refrigerant piping which supports the design pressure.
The piping specifications, please refer to chapter **5 REFRIGERANT PIPING WORK**
- Be sure to connect the indoor unit, which is dedicated to R32. See the catalog for indoor unit models which can be connected.
(Normal operation is not possible when connected to other units.)

Outdoor Unit	Design Pressure	
	RZFC71CRV16	High
	Low	2.76

(Units: MPa)

READ THESE INSTRUCTIONS CAREFULLY BEFORE INSTALLATION

- This manual classifies the precautions into WARNINGS and CAUTIONS. Be sure to follow all the precautions below. They are all important for ensuring safety.

 WARNING	Indicates a potentially hazardous situation which, if not avoided, could result in death or serious injury.
 CAUTION	Indicates a potentially hazardous situation which, if not avoided, may result in minor or moderate injury. It may also be used to alert against unsafe practices.

- After the installation is completed, test the air conditioner and check if the air conditioner operates properly. Given the user adequate instructions concerning the use and cleaning of the indoor unit according to the operation manual. In particular, make sure to explain with regard to "SAFETY PRECAUTIONS" and "Not malfunction of the air conditioner". Ask the user to keep this manual and the operation manual together in a handy place for future reference.
- This air conditioner comes under the term "appliances not accessible to the general public".

WARNING

- Ask your local dealer or qualified personnel to carry out installation work. Improper installation may result in water leakage, electric shocks or a fire.
- Perform installation work in accordance with this installation manual.
- Improper installation may result in water leakage, electric shocks or a fire.
- Consult your local dealer regarding what to do in case of refrigerant leakage. When the indoor unit is installed in a small room, it is necessary to take proper measures so that the amount of any leaked refrigerant does not exceed the concentration limit in the event of a leakage. Otherwise, this may lead to an accident due to oxygen deficiency.
- Be sure to use only the specified parts and accessories for installation work. Failure to use the specified parts may result in the air conditioner fall down, water leakage, electric shocks, a fire, etc.
- Install the air conditioner on a foundation that can withstand its mass. Insufficient strength may result in the air conditioner fall down and causing injury.
- Carry out the specified installation work in consideration of strong winds, typhoons, or earthquakes. Improper installation may result in an accident such as the air conditioner falling.
- Make certain that all electric work is carried out by qualified personnel according to the applicable legislation (note 1) and this installation manual, using a separate circuit. In addition, even if the wiring is short, make sure to use a wiring that has sufficient length and never connect additional wiring to make the length sufficient. Insufficient capacity of the power supply circuit or improper electric construction may lead to electric shocks or a fire. (note 1) Applicable legislation means "All international, national and local directives, laws, regulations and/or codes which are relevant and applicable for a certain product or domain."
- Earth the air conditioner. Do not connect the earth wiring to gas or water piping, lightning conductor or telephone earth wiring. Incomplete earthing may cause electric shocks or a fire. 
- Be sure to install an earth leakage circuit breaker. Failure to do so may cause electric shocks or a fire.
- The appliance must be stored in a room without continuously operating ignition sources (for example : open flames, an operating gas appliance or an operating electric heater).
- Do not pierce or burn.
- Be aware that refrigerant may not contain an odor.
- Comply with national gas regulations.
- Be sure to switch off the unit before touching any electrical parts. Touching a live part may result in electric shocks.
- Make sure that all wiring is secure, using the specified wiring and ensuring that external forces do not act on the terminal connections or wiring. Incomplete connection or fixing may cause overheating terminals or fire.
- When wiring between the outdoor and indoor units, and wiring the power supply, from the wiring orderly so that the structural parts such as a cover can be securely fastened. If the cover is not in place, electric shocks or a fire may be caused.
- Do not add wiring. It may result in heat generation. Electric shocks or fire.
- When installing or relocating the air conditioner, be sure to bleed the refrigerant circuit to ensure, it is free of air, and use only the specified refrigerant (R32). The presence of air or other foreign matter in the refrigerant circuit causes abnormal pressure rise, which may result in equipment damage and even injury.
- If refrigerant gas leaks during installation work, ventilate the area immediately. Toxic gas may be produced if refrigerant gas comes into contact with a fire.
- After completing the installation work, check to make sure that there is no leakage of refrigerant gas. Toxic gas may be produced if refrigerant gas leaks into the room and comes into contact with a source of a fire, such as a fan heater, stove or cooker.
- Never directly touch any accidental leaking refrigerant. This could result in severe wounds caused by frostbite.
- Do not stand on the outdoor unit or put things on it. The unit may fall down or drop, and cause accidents.
- Do not charge any refrigerant into the refrigeration cycle other than the designated refrigerant. It may cause an explosion or a fire due to leakage or a burst due to abnormally high pressure in the refrigeration cycle.
- Do not extend wiring on the way. It may cause heat generation, electric shocks or fire.
- At the installation work, install the refrigerant piping firmly before operating the compressor. If the compressor is operated without installing firmly and the service valve is in open condition, it sucks the air, etc., and the pressure inside the refrigerant circle becomes abnormally high. It may cause injury and breakage.
- At pump down work, stop the compressor before removing the refrigerant piping. If removing the refrigerant piping when the compressor is operated with its service valve in open condition, it sucks the air, etc., and the pressure inside the refrigerant circle become abnormally high, which may cause injury and breakage.
- The appliance (RZFC71CRV16) shall be installed operated and stored in a room with floor area larger 1.84 m².
- When flared joints are reused, the flare part shall be re-fabricated.

⚠ CAUTION

- Install drain piping according to this installation manual to ensure good drainage, and insulate the piping to prevent condensation. Improper drain piping may cause water leakage, make the furniture get wet.
- Install the indoor and outdoor units, power cord and connecting wires at least 1 meter away from televisions or radio to prevent picture interference and noise. (Depending on the incoming signal strength, a distance of 1 meter may not be sufficient to eliminate noise.)
- Install the indoor unit as far as possible from fluorescent lamps.
- In a domestic environment this product may cause radio interference in which case the user may be required to take adequate measures.
- Make sure to provide for adequate measures in order to prevent that the outdoor unit be used as a shelter by small animals. Small animals making contact with electrical parts can cause malfunctions, smoke or fire. Please instruct the customer to keep the area around the unit clean.
- Disposal requirements
Dismantling of the unit, treatment of the refrigerant, of oil and of other parts must be done in accordance with relevant local and national legislation.
- Only qualified personnel can handle, fill, purge and dispose of the refrigerant.
- Do not install the air conditioner in places such as following:
 1. Where there is mist of oil, oil spray or vapor for example a kitchen. Resin parts may deteriorate, and cause them to fall out or water to leak.
 2. Where corrosive gas, such as sulfurous acid gas, is produced. Corrosion of copper pipings or brazed parts may cause the refrigerant to leak.
 3. Where there is machinery which emits electromagnetic waves. Electromagnetic waves may disturb the control system, and cause malfunction of the equipment.
 4. Where flammable gases may leak, where carbon fiber or ignitable dust is suspended in the air or where volatile flammables, such as thinner or gasoline, are handled. If the gas should leak and remain around the air conditioner, it may cause ignition.
 5. The place that the vibration or the voltage fluctuation give influence. Vehicles, vessels, etc. The vibration may cause a damage and the voltage fluctuation may cause an abnormal operation.
 6. Where small animals may build a nest, fallen leaves are accumulated, or weeds are overgrown. If small animals touch the electrical parts inside, this may cause malfunction, smoke or a fire.

■ Important information regarding the refrigerant used
 This product contains fluorinated greenhouse gases covered by the Kyoto Protocol. Do not vent gases into the atmosphere.
 Refrigerant type: R32
 GWP⁽¹⁾ value: 675
 • ⁽¹⁾GWP = global warming potential
 The refrigerant quantity is indicated on the unit name plate.

1 BEFORE INSTALLATION <DO NOT THROW AWAY ACCESSORIES FOR INSTALLATION>

⚠ CAUTION

- Read these instructions carefully before ins
 For installation of the indoor unit,
 refer to the indoor unit installation manual.

RZFC71CRV16

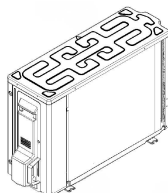

Note: All shapes or appearance may vary from actual parts.

HANDLING

As shown in the figure, bring the unit slowly by grabbing the left and right grips.
 (Take care not to let hands or objects come in contact with rear fins.)

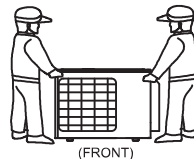
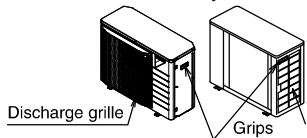

(FRONT)

Place your hands on the corner instead of holding the suction inlet in the side of the casing, otherwise the casing could be deformed.

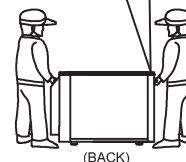

(BACK)

INSTALLATION CONSTRUCTION ACCESSORIES

Be sure only to use accessories made by DAIKIN which are specifically designed for use with the equipment.

CAUTION

Work in a team of at least two people when carrying the outdoor unit

2 SELECTING INSTALLATION SITE (1/2)

- (1) Select the installation location that meets the following conditions and get approval of the customer.
- Places where there is no risk of flammable gas leakage.
 - Places where the outdoor unit does not bother next-door neighbors.
 - Safe places which can withstand the unit's mass and vibration and where the air conditioner can be installed level.
 - Places that are well-ventilated and where servicing space can be well ensured.
 The minimum required space is shown in chapter ③ INSTALLATION SERVICE SPACE
 - Where the piping length between the indoor and the outdoor units is ensured within the allowable piping length. Please see chapter ⑤ REFRIGERANT PIPING WORK
 - Do not allow wind from the same direction to blow frequently toward the outlet or inlet of the outdoor unit. If the wind is likely to blow as mentioned above, make sure to keep a sufficient service space and install a wind protective shield.

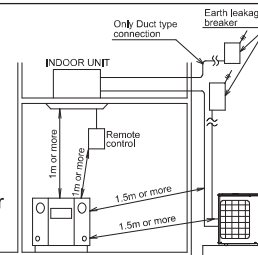

⚠ CAUTION

Inverter air conditioners may cause noise to occur in electrical appliances. As shown in the right drawing, select an installation site well away from radios, PCs, and stereos. Especially in the areas where the incoming signal strength is weak, keep the indoor remote controller 3 meter or more from electrical appliances. Put the power supply and transmission wiring in a metal piping and ground the metal piping.

2 SELECTING INSTALLATION SITE (2/2)

⚠ CAUTION

- In a domestic environment this product may cause radio interference in which case the user may be required to take adequate measures.
- When installing the unit in a place exposed to strong wind, pay special attention to the following. Strong winds of 5 m/sec or more blowing against the outdoor unit's air outlet causes short circuit (suction of discharge air) and this may have the following consequences:
 - Deterioration of the operational capacity.
 - Disruption of operation due to rise of high pressure.
 - When a strong wind blows continuously on the face of the unit, the fan can start rotating very fast until it breaks.
 Refer to the figures for installation of this unit in a place where the wind direction can be foreseen.
- Following the installation place, it is expected that the influence of the strong wind is great.
 - The flat area which receives the adverse wind such as typhoon directly since there is no obstacles such as buildings and mountains. (Including coast line, shoreline of lake and mountain region.)
 - The installation place that no obstacles around the outdoor unit to prevent the adverse wind, for example, walls and buildings that are higher than the applicable outdoor unit, etc. Please take measures when installing especially on a rooftop.
 - Since the outdoor unit may fall down, attach the fixture for preventing overturning(option).

Turn the air discharge toward the building's wall fence or screen.



Make sure there is enough room to do the installation

STRONG WIND

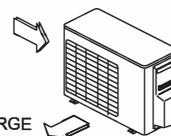

Set the outlet side at right angle to the direction of the wind.

AIR DISCHARGE

STRONG WIND

- Prepare a water drainage channel around the foundation, to drain waste water from around the unit.
- If the water drainage of the unit is not easy, please build up the unit on a foundation of concrete blocks, etc. (the height of the foundation should be maximum 150 mm).
- If you install the unit on a frame, please install a waterproof plate within 150 mm of the underside of the unit in order to prevent the invasion of water from the lower direction.

3 INSTALLATION SERVICE SPACE (1/3)

- The installation servicing spaces shown in these drawings are based on the outdoor unit inlet area temperature of 35°C for COOLING operation.

If the planned inlet area temperature exceeds 35°C(DB), or if the heat load of all outdoor units is increased significantly and exceeds the maximum operating capacity, secure a larger space than that indicated by the inlet dimensions in these drawings.

- For installation, consider both pedestrian and air flow paths and choose a suitable pattern from these drawings to match the space available field. (If the number of units to be installed exceeds the patterns in these drawings, consider there is no short-circuits.)
- Regarding the front space, position the units with consideration to the space required for the refrigerant piping work. (Consult your dealer if the work conditions do not match those in the drawings.)
- Secure appropriate space when using a side piping outlet.

STAND-ALONE INSTALLATION

No Obstacle above

- Obstacle on the suction side only

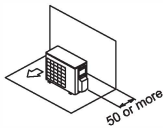

- To secure service space, more than 250 mm of each products at right side in needed.

(Units: mm)

- Obstacle on both sides and suction side, too

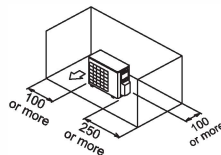

- Obstacle on the discharge side only

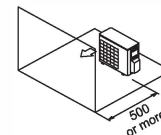

Obstacle above, too

- Obstacle on the suction side, too

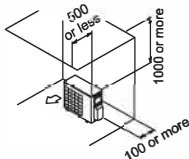

- Obstacle on both sides and suction side, too

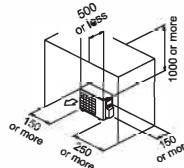

- Obstacle on the discharge side only, too

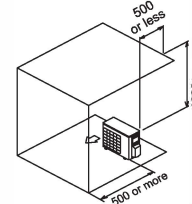

Note: All shapes or appearance may vary from actual parts.

3 INSTALLATION SERVICE SPACE (2/3)

When there are obstacles on both suction and discharge sides

- To secure service space, (Units: mm)
more than 250 mm of each products at right side is needed.

Pattern 1 When the obstacles on the discharge side is higher than the unit

- 1) No obstacle above (There is no limit for the height of obstructions on the suction side.)
- 2) Obstacle above, too
The relations between H, A and L are as follows.

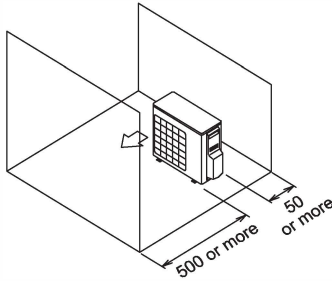

	L	A
$L \leq H$	$L \leq 0.5H$	750 or more
	$0.5H < L \leq H$	1000 or more
$L > H$	Set the stand as: $L \leq H$	

- ※ - Close the bottom of the stand to prevent the discharged air from being bypassed.
- The limitation of facilities connection is until 2 unit only.
- In case of more than dimension in (), It is no need to establish the stand although $L > H$

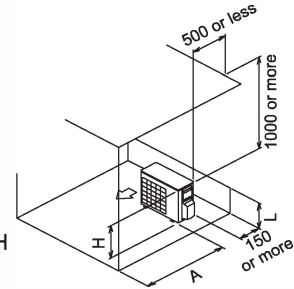

Pattern 2 When the obstacle on the discharge side is lower than the unit

- 1) No obstacle above (There is no limit for the height of obstructions on the suction side.)
- 2) Obstacle above, too
The relations between H, A and L are as follows.

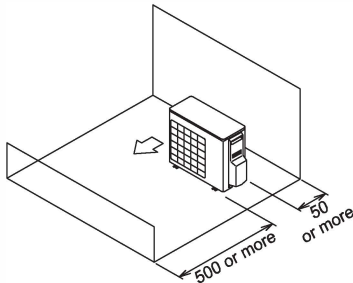

	L	A
$L \leq H$	$L \leq 0.5H$	50 or more
	$0.5H < L \leq H$	100 or more
$L > H$	Set the stand as: $L \leq H$	

- ※ - Close the bottom of the stand to prevent the discharged air from being bypassed.
- The limitation of facilities connection is until 2 unit only.
- In case of more than dimension in (), It is no need to establish the stand although $L > H$

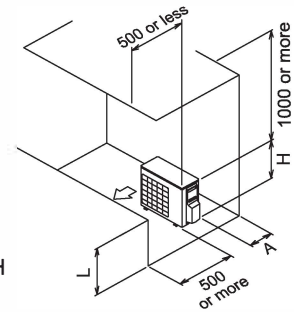

SERIES INSTALLATION (2 OR MORE)

- ※ Inside extraction, please provide the space of piping.
- To secure service space, more than 250 mm of each products at right side is needed. (Units: mm)

No obstacle above

- 1) Obstacle on the suction side and both sides

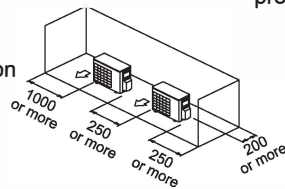

- 2) Obstacle on the discharge side only

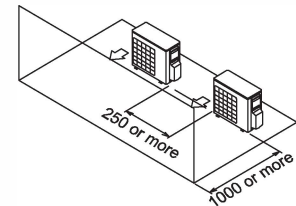

Obstacle above, too

- 1) Obstacle on the discharge side

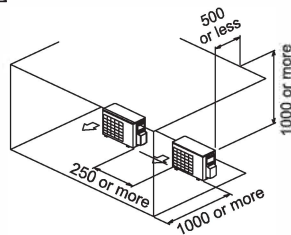

- 2) Obstacle on the suction side and both sides

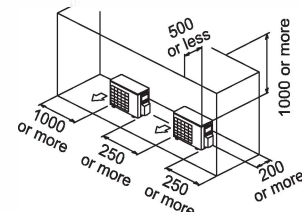

Note: All shapes or appearance may vary from actual parts.

3 INSTALLATION SERVICE SPACE (3/3)

When there are obstacles on both suction and discharge sides

- To secure service space, more than 250 mm of each products at right side is needed.

Pattern 1 When the obstacles on the discharge side is higher than the side unit

- 1) No obstacle above (There is no limit for the height of obstructions on the suction side.)

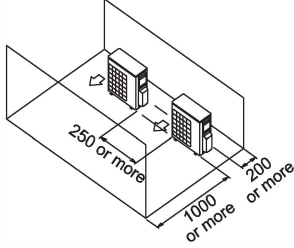

- 2) Obstacle above, too
The relations between H, A and L are as follows.

	L	A
$L \leq H$	$L \leq 0.5H$	1000 or more
	$0.5H < L \leq H$	1250 or more
$L > H$	Set the stand as: $L \leq H$	

- Close the bottom of the stand to prevent the discharged air from being bypassed.
- The limitation of facilities connection is until 2 unit only.
- In case of more than dimension in (), It is no need to establish the stand although $L > H$

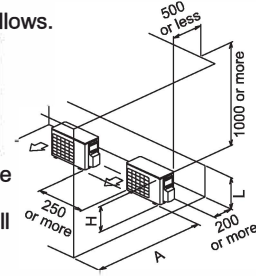

Pattern 2 When the obstacle on the discharge side is lower than the unit

- 1) No obstacle above
(There is no limit for the height of obstructions on the suction side.)

- 2) Obstacle above, too

(Units: mm)

The relations between H, A and L are as follows. The relations between H, A and L are as follows.

L	A
$L \leq 0.5H$	150 or more
$0.5H < L \leq H$	200 or more

	L	A
$L \leq H$	$L \leq 0.5H$	150 or more
	$0.5H < L \leq H$	200 or more
$L > H$	Set the stand as: $L \leq H$	

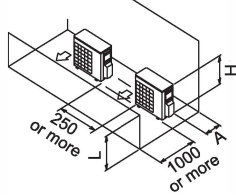

- Close the bottom of the stand to prevent the discharged air from being bypassed.
- The limitation of facilities connection is until 2 unit only.
- In case of more than dimension in (), It is no need to establish the stand although $L > H$

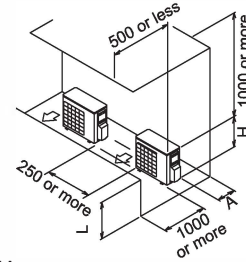

DOUBLE-DECKER INSTALLATION

- Do not stack more than two unit.
- The drain piping construction size of upper side outdoor unit is needed about 100 mm.
- In side extraction, please provide the space of piping.

(Units: mm)

- 1) Obstacle on the discharge side

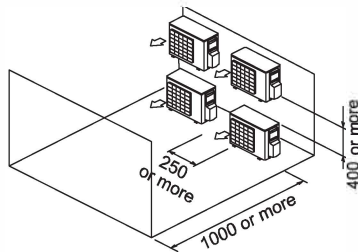

- 2) Obstacle on the suction side

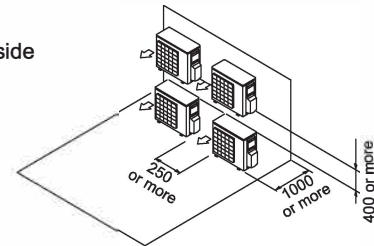

MULTIPLE ROWS OF SERIES INSTALLATION (ON THE ROOFTOP, ETC.)

- 1) One row of stand-alone installation

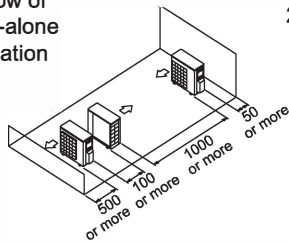

- 2) Rows of series installation (2 or more)

The relations between H, A and L are as follows.

	L	A
$L \leq H$	$L \leq 0.5H$	150 or more
	$0.5H < L \leq H$	200 or more
$L > H$	Can not be installed	

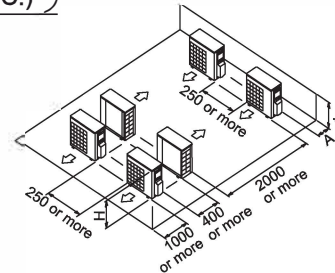

Note: All shapes or appearance may vary from actual parts.

4 PRECAUTIONS ON INSTALLATION

- Check the strength and level of the installation ground so that the unit will not cause any operating vibration or noise after installed.
- In accordance with the foundation drawing in Fig. 1, fix the unit securely by means of the foundation bolts. (Prepare 4 sets of M12 foundation bolts, nuts and washers each which are available on the market.)
- It is best to screw in the foundation bolts until their length are 20 mm from the foundation surface.
- Fix the outdoor unit to the foundation bolts using nuts with resin washers. (See the left-hand of Fig. 1 drawing)
If the coating on the fastening area is stripped off, the nuts rust easily.

<Drain pipe disposal>

- If drain pipe disposal from the outdoor unit causes trouble, (for example, if the drain water may splash on people) provide the drain piping by using of the drain plug (optional).
- Then, coat the area around the bored holes with rust preventive coating to cover the metal exposure.
- Make sure the drain works properly.

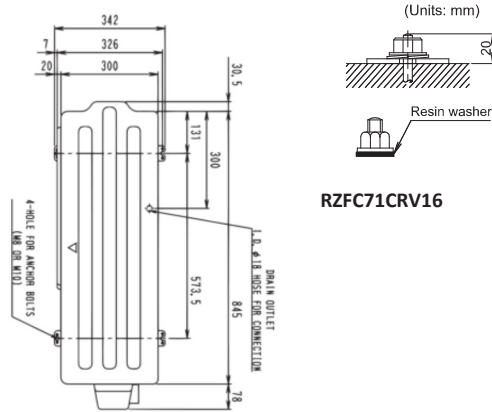

Fig : 1

5 REFRIGERANT PIPING WORK (1/4)

CAUTION

To plumbing person

- Important information regarding the refrigerant used. This product contains fluorinated greenhouse gases covered by the Kyoto Protocol. Do not vent gases into the atmosphere. GWP (global warming potential) of R32 refrigerant type = 675.
- Use R32 as additional for charging.
- Do not use flux when brazing refrigerant piping.
- Use phosphor copper brazing filler metal (BCuP-2:JIS Z 3264/B-Cu93P-710/795:ISO 3677) that does not require flux. (If chlorinated flux is used, the piping will be corroded and, in addition if fluorine is contained, the refrigerant oil will be deteriorated and the refrigerant circuit will be affected badly.)
- After chapter 7 CHARGING REFRIGERANT is completed, be sure to open the stop valves before performing 9 LOCAL SETUP. (Operating the unit with the valve shut will break the compressor.)

«Precaution when reuse existed refrigerant pipe»

Please keep below points in order to reuse existed pipe, failure may caused if have a fault.

- Below are pipes shall always make new construction, do not reuse piping.
 - When removed from indoor unit or outdoor unit for a long time, (Moisture entry to internal pipe, wastes entry can be occurred.)
 - When copper tube is corroded.
 - When pipe thickness is insufficient (refer to 5-4 REFRIGERANT PIPE SIZE AND ALLOWABLE PIPE LENGTH)
 - Do not reuse flare for refrigerant leak protection, please make flare processing.
 - Do not reuse flare nut, please use flare nut in product accessories.
 - Make sure to do refrigerant leak check in case there is brazing area while perform field piping.
 - If insulation is deteriorate, make sure to exchange to new one.

5-1 INSTALLATION TOOLS

Be sure to use the dedicated tools to ensure sufficient pressure resistance and prevent the entry of any impurities.

Manifold gauge	To ensure sufficient pressure resistance and prevent the entry of any impurities (mineral oils such as Suniso oil and liquids), use the R410A or R32 dedicated item (the screw specifications for R410A or R32 differ).
Charging hose	
Vacuum pump	Be extremely careful not to flow the pump oil backward to inside the piping when the pump is stopped. Use a pump which enables vacuuming to -0.1 MPa(-755mmHg) of the gauge pressure.

5-2 SELECTION OF PIPING MATERIAL

- Use the piping whose inside and outside are clean and with no harmful substances for use such as sulphur, oxide, dust, dust from cutting, grease, or liquid (contamination) is attached.
- For the refrigerant piping, use the following material.

Material: Deoxidised phosphorous seamless copper piping

Temper grade: Use piping with temper grade in function of piping diameter as listed in the table on section

5-4 REFRIGERANT PIPE SIZE AND ALLOWABLE PIPE LENGTH

Size: Decide based on section 5-4 REFRIGERANT PIPE SIZE AND ALLOWABLE PIPE LENGTH

Thickness: Comply with applicable legislation. The minimal piping thickness for R32 piping must be in accordance with the table on section

5-4 REFRIGERANT PIPE SIZE AND ALLOWABLE PIPE LENGTH

- Be sure to perform piping work using measurements within the maximum allowable length and height difference described on section 5-4 REFRIGERANT PIPE SIZE AND ALLOWABLE PIPE LENGTH

5 REFRIGERANT PIPING WORK (2/4)

<Please refer to installation manual of indoor unit about indoor unit's refrigerant piping>

5-3 CARE OF PIPE

- Prevent contamination or moisture from getting into the piping.
- Pay special attention when running the copper piping through the through-hole or when leading the edge of the piping outside the room.
- Refrigerant piping must be protected from physical damage. Install a plastic cover or equivalent.

PLACE	INSTALLATION PERIOD	PROTECTION METHOD	PLACE	INSTALLATION PERIOD	PROTECTION METHOD
OUTDOOR	More than a month	Pinch the pipe	INDOOR	Unquestioned	Pinch or tape pipe
	Less than a month	Pinch or tape pipe			

5-4 REFRIGERANT PIPE SIZE AND ALLOWABLE PIPE LENGTH

- One way maximum allowable piping length means the maximum length of liquid side piping or gas side piping.
- Equivalent length is the pressure loss due to L joints, traps, and so on along the refrigerant piping converted to a straight piping length of the same size and added to the overall value.
Please see the Engineering Data for calculation of equivalent length.
- Please give the vertical interval between the indoor and outdoor as 20m or less.

CAUTION

This unit is chargeless specification. Due to chargeless length and allowable piping length will be different depend on field pipe size.

Piping bend radius

(Units : mm)

Piping diameter	Pipe thickness (material)	Bend radius
Ø 6.4mm	0.7 mm (C1220T-O, Type O)	30mm or more
Ø 15.9mm	0.8 mm (C1220T-O, Type O)	50mm or more

Refrigerant pipe size and chargeless length

Outdoor unit type	Liquid pipe size (type)	Chargeless length
RZFC71CRV16	Ø 6.4mm x t 0.7 mm (type O)	10m

WARNING

- When flared joints are reused in indoors, the flared part shall be re-fabricated.

CAUTION

- Use dedicated piping cutters and flaring tools for R410A or R32.
- When making a flare connection, apply ether or ester oil only to the flare inner surface.
- Use only the flare nuts attached to the unit. If other flare nuts are used, it may cause refrigerant leakage.
- To prevent contamination, dust or moisture from getting into the piping, take measures such as pinching or taping the piping.

5-5 CONSTRUCTION OF REFRIGERANT PIPING

- Field pipes can be installed in Back - side connection. <Fig.2>
- Do not allow any substances other than the specified refrigerant such as air to mix into the refrigerant circuit.

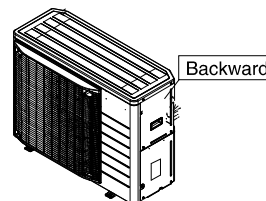

<Fig. 2>

Note: All shapes or appearance may vary from actual parts.

5 REFRIGERANT PIPING WORK (3/4)

<Please refer to installation manual of indoor unit about indoor unit's refrigerant piping>

PREVENTING FOREIGN OBJECTS FROM ENTERING

- Plug the pipe through-holes with putty or insulating material (field supply) to cover all gaps, as shown in the figure.
- Insects or small animals entering the outdoor unit may cause a short circuit in the electrical box.

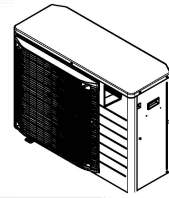

Putty or insulation material (Field supply)
Refrigerant piping must be protected from physical damage. Install a plastic cover or equivalent.

CAUTIONS FOR HANDLING STOP VALVE

DO NOT OPEN THE STOP VALVE UNTIL **7 CHARGING REFRIGERANT** FINISHED.

- The stop valves for indoor-outdoor connecting piping are closed at shipment from the factory. The names of parts are shown in figure on the right.
- Since the side boards may be deformed if only a torque wrench is used when loosening or tightening flare nuts, always lock the stop valve with a wrenches and then use a torque wrench.

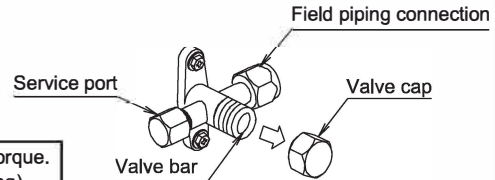

When tightening the flare of the stop valves, make sure to tighten by the rated torque. The rated torque is shown on **(CAUTION FOR FLARE CONNECTION)** (Following)

DO NOT APPLY FORCE ON THE VALVE CAP, THIS MAY RESULT IN A REFRIGERANT LEAK.

- For cooling operation under low ambient temperature or any other operation under low pressure, apply silicon pad or similar to prevent freezing of the gas stop valve flare nut (see figure).

Freezing of the flare nut may cause refrigerant leak.

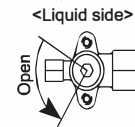
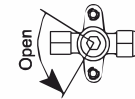
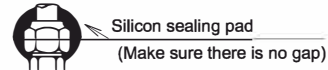

How to operate the stop valve

Use hexagonal wrenches 5mm.

- Opening the valve**
1. Place the hex wrench on the valve bar and turn counter-clockwise.
 2. Stop when the valve bar no longer turns. (It is now open.)

- Closing the valve**
1. Place the hex wrench on the valve bar and turn clockwise.
 2. Stop when the valve bar no longer turns. (It is now close.)

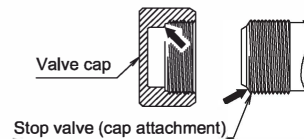

CAUTIONS FOR HANDING VALVE CAP

- A seal is attached to the point indicated by the arrow. Take care not to damage it.
- Be sure to tighten the valve cap securely after operating the valves.

	Valve size (mm)	Tightening torque(N·m)	Valve size (mm)	Tightening torque(N·m)
Liquid side	ø6.4	15.7 ± 1.5 N·m	Gas side	ø15.9
				54.9 ± 5.4

CAUTIONS FOR HANDLING SERVICE PORT

- Always use a flexible charge hose with a push-rod and valve to enable recovery of remaining refrigerant in the charge hose.
- After the work, tighten the valve cap in place.
- Tightening torque: $12.7 \pm 1.2 \text{ N}\cdot\text{m}$



Do not use a charging hose of which pressing stick is slipped out from the center. (It may cause refrigerant leakage due to deformation to the valve stem of the service port)

PRECAUTIONS FOR CONNECTING PIPING

- Take caution so that the refrigerant piping between the outdoor and indoor may not touch and sound proof cover and the plate as shown figure.
- If installing the outdoor unit higher than the indoor unit, caulk the space around insulation and tubes because condensation on the stop valves can seep through to the indoor unit side.

PRECAUTIONS REGARDING INSULATION

Enhance the insulation of the refrigerant piping according to the installation conditions. If this is not done, condensation may form on the surface of the insulation. Please refer to the target values shown below.

- When the temperature and humidity conditions are 30°C and RH 75% or more: thickness of the insulation is 15 mm or more.
- When the temperature and humidity conditions are 30°C and RH 80% or more: thickness of the insulation is 20 mm or more.
- Be sure to insulate the liquid and gas sides interunit piping.

It may become the cause of refrigerant leakage if it is not insulated. (Be sure to use insulating material which can resistant.)

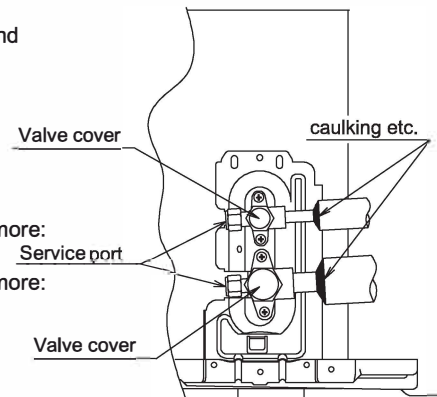

Insulation of interunit piping must be carried out up to the connection inside the casing. If the piping is exposed to the atmosphere, it may cause sweating or burn due to touching the piping, electric shocks or a fire due to the wiring touching the piping.

5 REFRIGERANT PIPING WORK (4/4)

CAUTION FOR FLARE CONNECTION

- Please be sure to remove a flare nut with a two-dish spanner, and to bind after connection of piping using a spanner and a torque wrench.
- Refer to the following table for a flare part processing size.
- When connecting the flare nut, apply refrigerating machine oil to the flare (inside) and at first screw the nut 3 or 4 turns by hand. Coat here with ether or ester oil.
- Refer to the table for the dimensions for processing flares and for the tightening torques. (Too much tightening will end up in splitting of the flare.)
- After completing the installation, carry out a gas leak inspection of the piping connections with nitrogen and such.

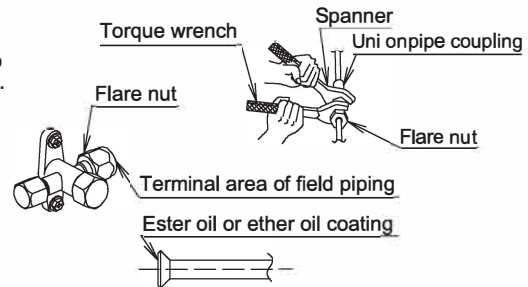

PIPING SIZE (mm)	TIGHTENING TORQUE	A DIMENSIONS FOR PROCESSING FLARES (mm)	FLARE SHAPE
Ø6.4	15.7 ± 1.5 N·m	8.9 ± 0.2	
Ø9.5	36.3 ± 3.6 N·m	13.0 ± 0.2	
Ø12.7	54.9 ± 5.4 N·m	16.4 ± 0.2	
Ø15.9	68.6 ± 6.8 N·m	19.5 ± 0.2	
Ø19.1	108.0 ± 10.8 N·m	23.8 ± 0.2	

- If a torque wrench is not available, be aware that the tightening torque may increase suddenly. Do not tighten nuts any further than to the angle as listed.
- When work is completed, be sure to check that there is no gas leakage.
 - ① A flare nut is bound tight with a spanner to the position whose torque with a bundle increases suddenly.
 - ② Only the angle of a right table is further bound tight from the position.

PIPING SIZE (mm)	FURTHER TIGHTENING ANGLE	RECOMMENDED ARM LENGTH OF TOOL
Ø6.4	60 to 90 degrees	About 150 mm
Ø9.5	60 to 90 degrees	About 200 mm
Ø12.7	30 to 60 degrees	About 250 mm
Ø15.9	30 to 60 degrees	About 300 mm
Ø19.1	20 to 35 degrees	About 450 mm

PRECAUTIONS WHEN BRAZING THE REFRIGERANT PIPINGS

<Do not reuse joint which have been used once already>

- When brazing the refrigerant piping, carry out brazing work (NOTE 2) after substituting nitrogen for air (flow nitrogen into the piping and substitute nitrogen for air (NOTE 1) (see the drawing below)).

NOTES

1. The proper pressure for having nitrogen flow through the piping is approximately 0.02MPa, a pressure that makes one feel like breeze and can be obtained through a pressure reducing valve.
2. Do not use flux when brazing refrigerant piping. Use phosphor copper brazing filler metal (BCuP-2: JIS Z 3264/B-Cu93P-710/795:ISO 3677) that does not require flux. (If chlorinated flux is used, the piping will be corroded and, in addition if fluorine is contained, the refrigerant oil will be deteriorated and the refrigerant circuit will be affected badly.)

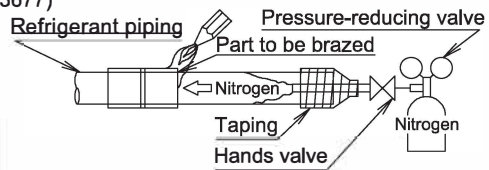

Do not use anti-oxidants when brazing the piping joints. (Residue can clog pipes and break equipment.)

6 AIRTIGHTNESS TEST AND AIR-PURGE

AIRTIGHTNESS TEST

- Perform a refrigerant leakage check using nitrogen gas (airtightness test) with the outdoor unit stop valve close, to make sure there are no leakage.
- For the airtightness test, raise the pressure to the design pressure in the high pressure section (4.17 MPa) For the airtightness test, the unit passes the test if the pressure in the high pressure section does not drop for 24 hours after increasing to the design pressure. A correction is required since the pressure decreases approx. 0.01Mpa when the ambient temperature of 1°C decreases.
- If the pressure drop is confirmed, perform the airtightness test again after checking and modifying the leakage points.

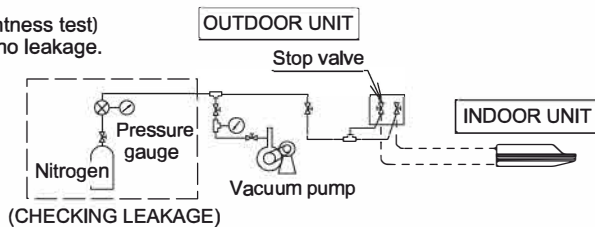

AIR-PURGE

- Evacuate by the vacuum pump for more than 2 hours until the internal pressure decreases below -0.1MP. After that, leave it with -0.1MPa or less for more than one hour and confirm that the value of vacuum gauges does not increase.
- If the value of vacuum gauge increases, there is moisture inside the refrigerant piping or there are leakage points. Perform evacuation again after checking and improving the leakage points.

NOTE

After doing an air-purge with a vacuum pump, the refrigerant pressure may not rise even if the stop valves are opened. This is because the refrigerant piping path is closed off by the outdoor unit electronic expansion valve, etc. There are no problems if the outdoor unit is running.

7 CHARGING REFRIGERANT (1/2) < Be sure to use R32 as refrigerant. >

ADDITIONAL REFRIGERANT CHARGING

This model is chargeless type, so it is not necessary to charge additionally if pipe does not exceed the maximum allowable length without additional charge.

Please refer to the following table about the maximum allowable length without additional charge.

Liquid piping size	Length for which additional charging is not required
ø6.4mm x t 0.7mm	10m

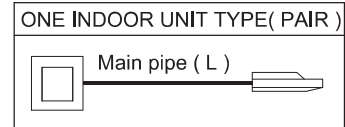

When piping length exceeds its of a top table,

or only when you perform recharging, Please be correctly charged according to the following.

For future servicing, please describe the amount of additional refrigerant charging, or the amount of recharging in the collective label in accessory set or back side of right side plate.

• In case of additional refrigerant charging

Please select the amount of additional refrigerant which suited piping length from the following table, and add it from the service port of liquid stop valve.

Outdoor units type	Liquid piping size	Length for which additional charging is not required	Length of piping exceeding the length for which additional charging is not required, R32 additional amount (kg)
			30m or less
RZFC71CRV16	ø6.4mm x t 0.7mm	10m	20 g per meter (For Piping Length Exceeding 10 m)

• Total refrigerant charging (When recharging due to exchange compressor, etc.)

Please charge refrigerant base on pipe length mentioned on the following table.

Outdoor units type	Liquid piping size	Piping length, R32 complete additional amount (kg)	
		5m~10m	20m or less
RZFC71CRV16	ø6.4mm	0.79	0.99

7 CHARGING REFRIGERANT (2/2)

Precautions when adding R32 • Before charging, check whether the cylinder has a siphon attached or not.

Charging a cylinder with an attached siphon



Stand the cylinder upright at charging.
(There is a siphon piping inside, so that cylinder need not be upside-down to charge with liquid.)

Charging other cylinders



Stand the cylinder upside-down and charge.
(Turn the cylinder upside-down at charging.)

- To prevent entry of any impurities and ensure sufficient pressure resistance, always use the special tools dedicated for R410A or R32.
- The refrigerant should be charged from the service port of the liquid side stop valve.



WARNING

To persons incharge of piping work

- Please be sure to open a stop valve after a refrigerant charging end (if it operates shut, a compressor will break down).
- After complete charging of refrigerant carry out refrigerant leak check and heat insulation work.
- Please do not emit a refrigerant into the atmosphere indiscriminately.

8 ELECTRICAL WIRING WORK (1/3)



WARNING

- Install the earth leakage circuit breaker. (A duty of installation of a earth leakage circuit breaker is imposed for an electric shock and fire accident prevention.
The inverter is provided in the air conditioner. In order to prevent malfunction of the earth leakage breaker itself, use a breaker resistant to higher harmonics).
- Electrical wiring must be carried out by qualified personnel.
- Before obtaining access to terminal devices, all supply circuits must be interrupted.



CAUTION

To the electrician

- Make sure to install a current balance type earth leakage breaker coping with high harmonics.
(This unit is equipped with an inverter device. Use an earth leakage breaker coping with high harmonics to prevent wrong actuation.)
- Do not run the unit until the refrigerant charging is complete. (Operating the unit before the completion will break the compressor.)
- Do not remove the thermistors or sensors when the power supply and transmission wiring are connected.
(Operating the unit with the thermistors and sensors removed will break the compressor.)
- Make certain that all electric wiring work is carried out by qualified personnel according to the applicable legislation and this installation manual, using a separate circuit. Insufficient capacity of the power supply circuit or improper electrical construction may lead to electric shocks or a fire.
- An insufficient power supply capacity or improper electric work may lead to electric shocks or a fire.
- The wiring between the indoor unit and outdoor unit must be for 230V.
- For electric wiring work, refer to also the "WIRING DIAGRAM attached with installation manual".
- When doing the electrical wiring, always shut off the power source before working, and do not turn on the branch switch until all work is complete.
- Make sure to earth the air conditioner. Earthing resistance should be according to applicable legislation.
- Do not connect the earth wiring to gas or water piping, lightning conductor or telephone earth wiring.
 - Gas piping.....Ignition or explosion may occur if the gas leaks.
 - Water piping.....Hard vinyl tubes are not effective earths.
 - Lightning conductor or telephone earth wiring.....Electric potential may rise abnormally if struck by a lightning bolt.
- The earth is needed in order to reduce the noise generated by the unit's inverter and influence on other appliances and to release the charged electric charge on the outdoor unit surface by leaked current.
- Do not install a phase advance capacitor for improvement of power factor. Since this unit is mounted with an inverter device, the effect of power factor improvement not only cannot be expected, but also there is a risk of the capacitor getting abnormally overheated due to harmonics.
- Be sure to use earth leakage breaker dedicated for earth leakage protection in combination with the load break switch with fuse or breaker for wiring.
- In case of three-phase. Machine, electric wiring must be connected in normal phase connection.
- For wiring, use the designated power supply wiring and connect firmly, then secure to prevent external force being exerted on the terminal attachment (power supply wiring, transmission wiring, earth wiring).
- Left-over wiring should not be wrapped and stuffed into the outdoor unit.
- To prevent the power wiring from being damaged by the knock hole edges, put it in a wiring piping or use insulated bush, etc. to protect it.
- To prevent the wiring from coming in contact with piping (particularly the high-pressure piping), secure it with the included clamping material as shown page 45.
- When wiring, form the wiring so that the front plate does not float and make sure the front plate is securely fastened.
- Fix the power supply wiring, the earth wiring and the transmission wiring by clamps as shown in the figure.

8 ELECTRICAL WIRING WORK (2/3)

- As shown in the following figure, please fix power supply wiring, field wiring and ground wire by clamp material.

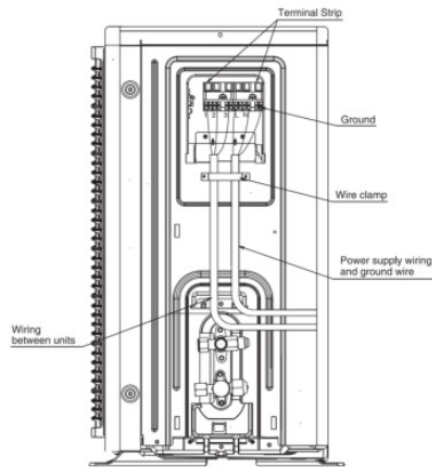

RZFC71CRV16

- Carry out insulated processing of attaching an insulated sleeve. Power supply wiring, wiring between units and ground tying with clamp as shown below.

⚠ Do not connect power supply to terminal block of transmission wiring. All system may get damaged.

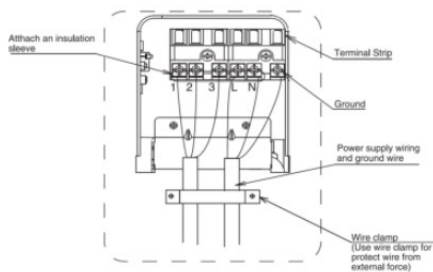

RZFC71CRV16

Connection of wiring

Precautions on wiring

- Use a round crimp-style terminal for connection to the power supply terminal board. In case it cannot be used due to unavoidable reasons, be sure to observe the following instruction.
- Do not connect wires of different gauge to the same power supply terminal. (Looseness in the connection may cause overheating.)

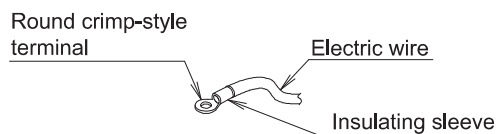

8 ELECTRICAL WIRING WORK (3/3)

When connecting wires of the same gauge, connect them according to the below figure.

Connect wires of the same gauge to both sides



Do not connect wires of different gauges



Do not connect wires of the same gauge to one side



- Never use the stranded wiring which is soldered. (Slack in the electric wiring may cause abnormal heat.)
- Use the required wirings, connect them securely and fix these wirings so that external force may not apply to the terminals.
- Use a proper screw driver for tightening the terminal screws. If an improper screw driver is used, it may damage the screw head and a proper tightening cannot be carried out.
- If a terminal is over tightened, it may be damaged. Refer to the table shown below for tightening torque of terminals.

Tightening torque (N•m)	
M4 (Wire between units terminal board)	1.50±0.30
M4 (Power supply terminal board)	1.50±0.30
M4 (Ground wire between units)	1.69±0.25
M5 (Ground wire between units)	3.55±0.50

Precautions on connecting terminal of grounding

- Ground wiring should be taken out from the cut out section of a cup washer. (Otherwise, contact of ground wiring is inadequate and it is ineffective.)

Ring type crimp-style terminal

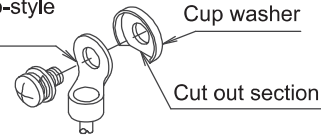

WIRING OF POWER SUPPLY AND THE UNITS

For details on the wiring of the indoor unit and wiring between units refer to the installation manual of the indoor unit.

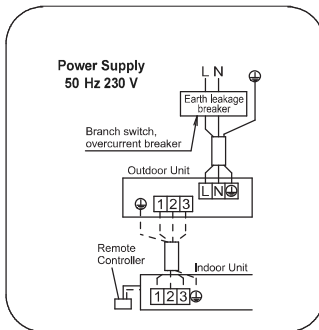

• SPECIFICATIONS OF STANDARD WIRING COMPONENTS

Outdoor Unit	Power supply			Wire type of wiring between the units
	Recommended field fuse	Wire type (*)	Size	
RZFC71CRV16	20 A	H05VV-U3G	Wiring size and length must comply with local codes or [IEC 60335-1 (Table 11)]	H05VV-U4G2.5

(*) Only in protected piping, use H07RN-F when protected pipes are not used.

(Supply cords shall not be lighter than polychloroprene sheathed flexible cord (code designation 60245 IEC 57))

NOTES

1. Select and install the power supply wiring in accordance with [IEC 60335-1 (Table 11)] or local laws and regulations. The maximum current of the outdoor and indoor units are shown on each name plate.
2. When installing wiring in a location that can easily come in contact with people, be sure to install an earth leakage breaker coping with high harmonics to prevent electric shock.
3. Breaker type and capacity shall be selected in accordance with local laws and regulations.

⚠ CAUTION

TO PERSONS INCHARGE OF ELECTRICAL WIRING WORK

- Do not operate the unit until the refrigerant charging is completed. (Running it before the piping is ready will break the compressor.)

9 CHECK ITEMS BEFORE TEST OPERATION AND FIELD SETTINGS

PRE-RUN CHECKS

	ITEM TO CHECK	CHECK
Power supply Wiring	Is the wiring as mentioned on the wiring diagram? make sure no wiring has been forgotten and that there are no missing phases or reverse phases.	
	Does wiring between units put in and changed in continuation installation?	
	Is the unit properly grounded?	
	Are any of the wiring attachment screws loose?	
	Is the insulation resistance at least 1MΩ? • Use a 500V mega-tester when measuring insulation • ※ Do not use a mega-tester to low voltage circuit except 220-240V.	
	Is an earth leakage circuit breaker used as a current operated type which is compatible to the higher harmonic wave? Does the earth leakage circuit breaker have appropriate rated current?	
Refrigerant piping	Is the size of the piping appropriate?	
	Is the insulation material for the piping attached securely? Are both the liquid and gas pipes insulated?	
	Are the stop valves for both the liquid side and the gas side open?	
Extra refrigerant	Did you write down the extra refrigerant and the refrigerant piping length?	
Indoor unit	Is the indoor unit fully installed? When the test run is started, the fan automatically begins turning.	

WARNING

- When a power supply is switched on, when you leave from the outdoor unit, be sure to close the cover plate. (It becomes the cause of an electric shock).

In field setting for an outdoor unit, make sure to shut down the power and check that there is no residual voltage before start installing. (It may cause an electric shock.)

10 TEST OPERATION

WARNING

- Never perform a test operation with the discharge piping thermistor(R2T) and suction piping thermistor(R3T) removed, as this might break the compressor.
- If the technician must leave the outdoor unit for some reason, switch places with another installation technician or close the plates. (It may cause electric shocks.)

HOW TO TEST OPERATION

After the indoor and outdoor unit installation, be sure to perform the test operation in accordance with the following procedure.

1. Open the stop valve cover and check that the liquid and gas sides of the stop valves are open.
<Be sure to close the front plate before the operation (there is a risk of electric shock)>
Note: After doing an air-purge with a vacuum pump, the refrigerant pressure may not rise even if the stop valves are opened. This is because the refrigerant piping path is closed off by the outdoor unit electronic expansion valve, etc. There are no problems if the unit is run.
2. Attach the stop valve cover to the outdoor unit and turn the power on at least 6 hours before operating the outdoor unit to protect the compressor.
3. Set to COOLING operation with the remote controller.
4. Perform the test operation
 - When doing trial operation, it may take about 1 minute until the compressor begins to function, but this is not abnormal.
 - When using the system the first time after installation, even if heating operation is selected, cooling operation will take place for about 3 to 5 minutes.
Thereafter, it will change to heating operation, but this is not abnormal.
(In this case, the remote controller display will continue to display "heating operation.") This is in order to detect if someone has forgotten to open the stop valve during trial operation.
 - If the outside air temperature is about 24°C or more, even if HEATING operation is set, the system may not operate, but this is not abnormal.
5. Operate normally.
6. Confirm function of the indoor and outdoor units according to the operation manual.

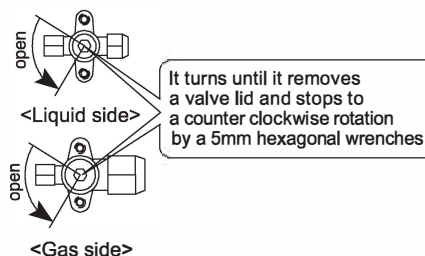

MALFUNCTION DIAGNOSIS

- At the time of a test run, when the following malfunction code is displayed on remote control, the fault of installation construction can be considered.

Malfunction code	Installation error	Remedial action
[E3] [E5] [U0] [L8]	A failure of a stop valve to open	"Open" operation of a stop valve
[E3] [E5] [L4] [L8]	Closing of an air passage	Removing closing thing from air passage
[U1]	Missing phase, negative phase	2 Phase of power supply 3 Phase (L1, L2, L3 Phase) are replaced
[U2]	Power supply unbalancing	Unbalanced dissolution
[U4] [UF]	Incorrect connection of field wiring	Correction of wiring
[UA]	Connection of incompatible indoor unit	Connect appropriate indoor unit (Refer to the catalogue)
NO INDICATION	Mistake wiring or not connect wiring of power supply, indoor, outdoor, field wiring between indoor unit	To correct wiring or connect correctly

- When malfunction codes other than the above are displayed on remote control, considering that the failure of between an indoor and an outdoor unit may have.
For the malfunction codes, please refer to the indoor unit's installation manual or outdoor service manual. (A malfunction code has what has a display according to the form of the interior of a room and an outdoor unit, and the thing which is not.)
- The followings can be considered causes when the breaker for power supply trips.
 - The capacity of a breaker for power supply is smaller than the required capacity of the leakage circuit breaker.
 - The leakage circuit breaker is not compatible to the higher harmonic wave.
- In case of already checking all equipment that not have any problem, but found air conditioner not cooling. Please re-check Motor operate valve coil not tighten or remove for 1st checking. If normally please re-confirm problem following service manual to solve problem.

CAUTION

To persons incharge of piping work and electric work

- Please check having attached the front board and the piping cover after a test run end when giving production over to customer.

11 CAUTION (RZFC71CRV16)

THIS IS NECESSARY FOR AFTER SERVICE, SO PLEASE REQUEST CUSTOMER TO KEEP THIS MANUAL.

CAUTION (NEW REFRIGERANT (R32 SERIES))



⊙ Caution about electric shock when do service inspection

1. After intercept power supply, do not open outside panel for 10 minutes.
2. Follow manufacturing label on electric box cover, please take off outdoor fan motor connector to confirm voltage and body static electricity discharge.

⊙ General caution items when do service inspection

Caution to confirm compressor and fan motor running

Do not directly connect power input (3 Phase 50Hz) to compressor and fan motor. (If not connect to print board (PCB), compressor and fan motor will be burned out.)

Caution when recharge refrigerant

1. To prevent the mixing of impurities, pressure resistance and contamination mix, please use manifold gauge especially for R32.
2. Make sure to do Nitrogen blow if brazing when flare connection. Apply ether oil or ester oil at inside flare only.
3. Do air tight test at 4.17Mpa.
4. Do dry vacuum, make sure to charge refrigerant in liquid condition from liquid side service port. (Compressor will be broken if charge from gas side service port.)

Caution when use outdoor PCB

Make sure to touch earth terminal and earthed metal before touch pcb, to prevent electric shock

Caution when break down diagnosis from letter code in remote control

Please refer to service guide or outdoor unit installation manual.

Charging refrigerant

• Charging the system with refrigerant

(For more information such as calculation method of additional refrigerant charge, additional charge method, refrigerant charge caution, refer to the installation manual and technical Guide.

- For refrigerant charge, be sure to charge from the service port of the liquid side stop valve in liquid states. (If you charge from the service port of the gas side stop valve, it may break the compressor.)
- Never charge other than the specified refrigerant. (It may cause fire and bursting.)

Table 1. Chargeless piping length

Liquid piping size	Pipe length which is not required additional charging
φ 6.4 mm x t0.7mm	10m

1. In case of additional refrigerant charging

Please add refrigerant amount according to the following table.

Outdoor	Liquid piping size	Pipe length which is not required additional charging	Pipe length over charge-less, R32 additional amount (Kg)
RZFC71CRV16	φ 6.4 x t0.7mm	10 m	+10m or less 0.200

2. Total refrigerant charging (Details please see service guide)

1. Please recover the refrigerant until becoming 0.09MPa (gauge pressure:-0.01MPa) or less by the refrigerant recovery machine from stop valve service port (liquid-gas side) at the same time.
2. Exchange service parts, modify leak point.
3. Perform airtightness test, air-purge.
Please refer installation manual of outdoor unit or service guide.
4. Charge refrigerant amount selected by table 2 from liquid stop valve service port.
Caution Do not turn on power during evacuation. The motor may be damaged due to vacuum discharge.

Table 2. Charge refrigerant amount (After a leak, etc...)

Outdoor	Liquid piping size	Piping length, R32 complete additional amount (kg)	
		5-10m	20m or less
RZFC71CRV16	φ 6.4 x t0.7mm	0.79	0.99

• Making a record of the added refrigerant charge amount

Be sure to record the piping length and added refrigerant charge amount or refrigerant recharge amount with an oil-based or other indelible marker so the figures will not fade over time. This information is necessary for after service and maintenance.

Liquid piping size	φ 6.4 mm x t0.7mm	
Refrigerant piping length		m
Additional refrigerant charging		kg
Recharge of refrigerant		kg

How to execute a pumping-down

(for example, when moving or reinstalling an indoor or outdoor unit)

The outdoor unit is equipped with a high pressure switch to protect the compressor.

Caution Never short circuit the high pressure switch during pump-down operation.

- It is not allowed to let the refrigerant out into air. The refrigerant should be recovered completely.
- Although pumping-down operation allows most of the refrigerant to be recovered in a short period of time, some refrigerant will remain inside the indoor unit and the refrigerant piping. Using a refrigerant recovery machine, recover remaining refrigerant from the stop valve service port until the pressure falls to 0.09MPa (gauge pressure:-0.011MPa) or less
- Be sure to execute the pumping-down before refrigerant piping and wiring is taking off.

⊙ For pumping-down operation

1. Please follow the [caution about electric shock when service inspection] which attached on Top panel (Caution: Do not take off the connector X106A)
2. To prevent electric shock, please protect power input terminal block by insulation sheet refer to below figure.
3. Turn on the power supply and carry out pumping-down operation according to the following procedure.

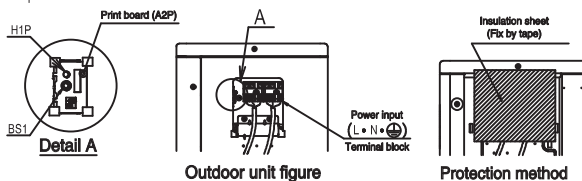

Caution To prevent electric shock when inspection, protect by use insulation sheet on power input terminal block and print board (A2P)

⊙ For pumping-down operation

Caution Do not remove the indoor unit until pump down operation finish. (It is dangerous when indoor fan automatically starts the operation.)

Perform pumping-down operation using the following procedure

Procedure	Precaution
1 Confirm that stop valves both on the liquid and gas sides are open	-
2 Push the pumping-down (BS1) on the PC board of the outdoor unit for 5 seconds.	Compressor and outdoor unit fan will start operation automatically. Indoor fan may automatically start running. Pay attention to this.
3 Close the stop valve on the liquid side securely about 2 minutes after the compressor started operation. Once the compressor operation stops after 2 to 5 minutes, close the stop valve on the gas side securely.	<ul style="list-style-type: none"> • Do never leave the outdoor unit unattended with opened front plate when power supply is on. • In case the stop valve on the liquid side is not securely closed during compressor operation, pumping-down operation cannot be executed
4 Turn off the power supply.	When you work alone, carry out after closing the front plate. After turning the power supply off, remove the insulation sheet.

- If after finishing pumping-down operation the outdoor unit does not operate, even when the remote controller switched on, the remote controller may or may not indicate "U4". But it is not a malfunction.
- To force of operation, turn off the main power supply and turn it on again. Make sure that stop valves both on liquid and gas sides are open and be sure to operate the unit in cooling operation during test run.

Liquid stop valve



Gas stop valve



Caution When installing and relocating, be sure to install the earth leakage breaker to protect from the electric shock disaster and fire due to leakage of electricity. For installing the earth leakage breaker, request to the qualified electrician.

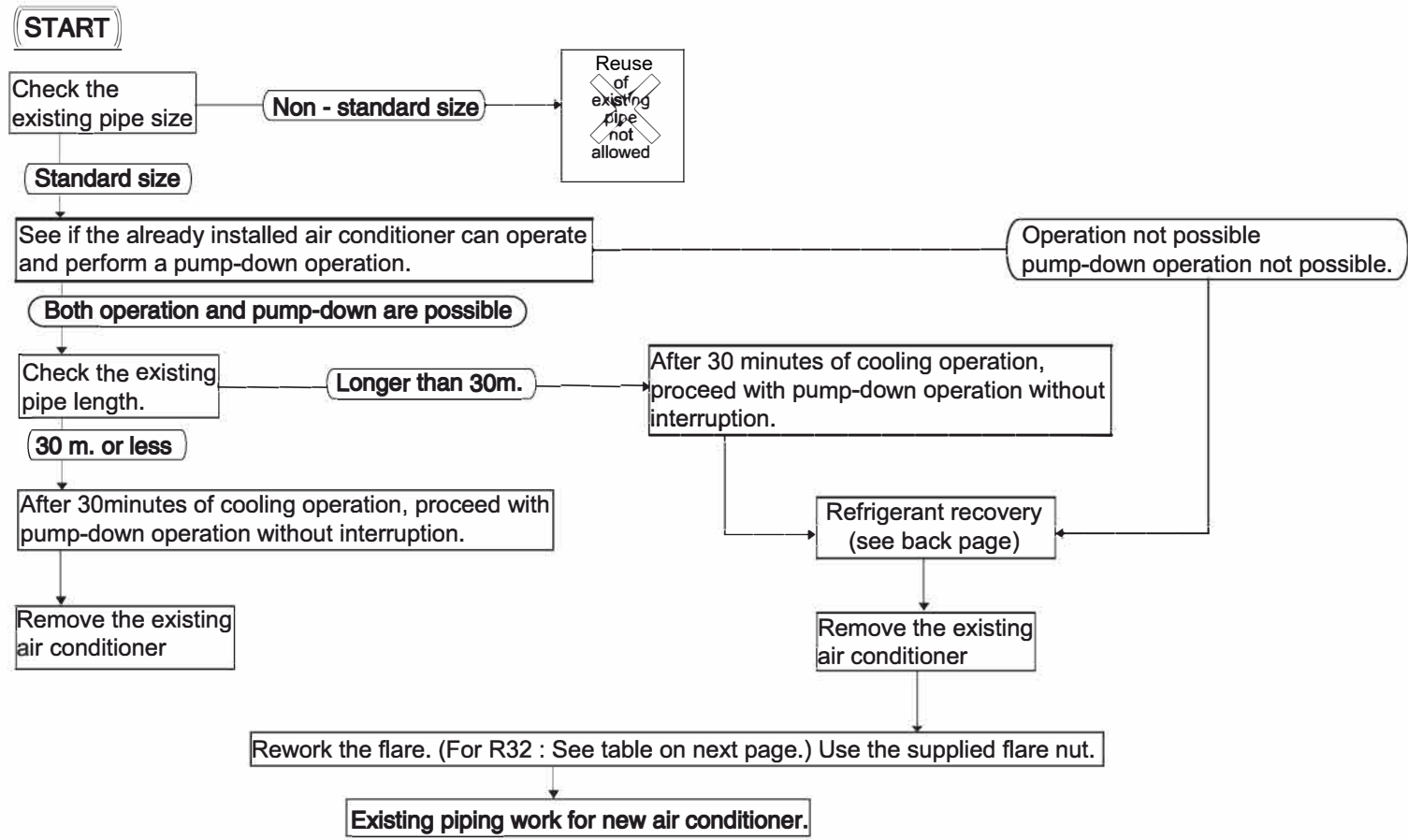

PRECAUTIONS ON REFRIGERANT PIPING

- Clean pipe if existing air conditioner is [gas, oil heat pump type].
- Clean pipe if used compressor oil in existing air conditioner is other than [SUNISO, MS, HAB, Barrel freeze, JOMO, Ethereal oil, Ester oil].
- Clean pipe if existing indoor and outdoor unit is disconnected.
- Change new pipe if refrigerant leakage or it should adding refrigerant.
- Change new heat insulation if existing part is peeling off.

(Note)

1. Clean the pipe if refrigerant leakage and unit has not service port on gas-liquid stop valve.
2. If indoor unit equipped with EV valve, open that valve before recovery refrigerant.
3. **Maximum pipe length as per specified on next page.**

13 REFRIGERANT RECOVERY

[Working procedure]

- 1. Recovery retaining oil in existing pipe Approx. 1 min**
Close gas stop valve (liquid stop valve: open) and recovery refrigerant from gas stop valve port.(Fig.1)
- 2. Recovery retaining oil in existing liquid pipe Approx. 1 min**
Recovery refrigerant from liquid stop valve port. (Fig.2)
- 3. Recovery refrigerant in outdoor unit Approx. 2-3 min**
Recovery refrigerant from outdoor unit refrigerant recovery port ^{*1}.(Fig.3)
NOTE 1 Can be omit this procedure if there is no refrigerant recovery port
- 4. Recovery refrigerant in accordance with Fluorocarbons Recovery and Destructive Law**
If refrigerant recovery port ^{*2} pressure become lower than gas stop valve port pressure, refrigerant will recover at the simultaneous from the gas stop valve port, open gas stop valve (Fig.3- 1) gradually to avoid from pressure rising rapidly. (Fig.3- 2)
NOTE 2 Can be omit this procedure if there has no refrigerant recovery port simultaneously if there has no refrigerant recovery port.

Retaining oil recovery amount improved approx. 5 times from regular refrigerant recovery method

(pipe length, height difference, pipe path etc. is difference by installation condition)

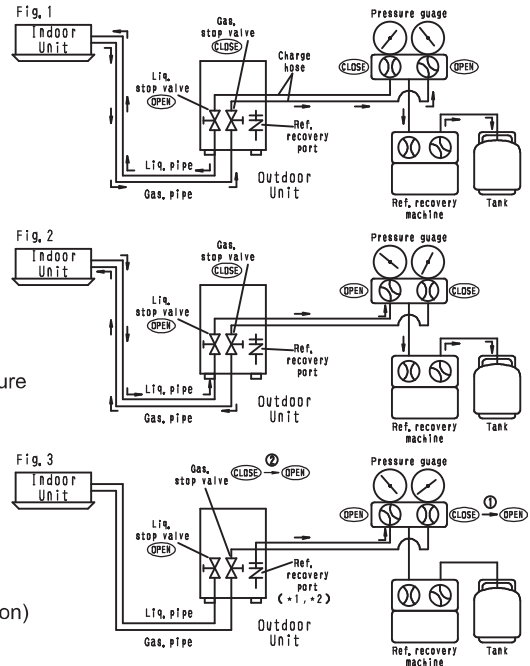

ABOUT FLARE PROCESSING

- Flare connection area of existed piping will cause processing deterioration, make sure to do newly re-processing.
- Flare processing [Unit: mm]

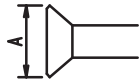

Piping outside diameter	A (+0, -0.4) For R32
φ 6.4	9.1
φ 15.9	16.4

- Please use flare nut which attached with product (Do not use existed flare nut)
- Flare nut [Unit: mm]



Piping outside diameter	B (+0, -0.6) For R32
φ 6.4	15
φ 15.9	22

REFRIGERANT PIPE SIZE TABLE

Outdoor Unit		Existing pipe size	6.4 / 15.9	Height difference	Design pressure (High pressure)
RZFC71CRV16	6.4 / 15.9	Standard pipe length	7.5 m	Max 16m	4.17 MPa
		Max. pipe length	20m		
		Chargeless pipe length	10m		

- Refer to the installation manual for details other than those mentioned above table such as additional refrigerant charge amount.
- Clean the existing piping if it length is exceed 30m.
- Clean the existing pipe if chargeless length is exceed limit of existing pipe pump down refrigerant recovery.

14. Unpacking & Packing of the Outdoor Unit

14-1 Unpacking

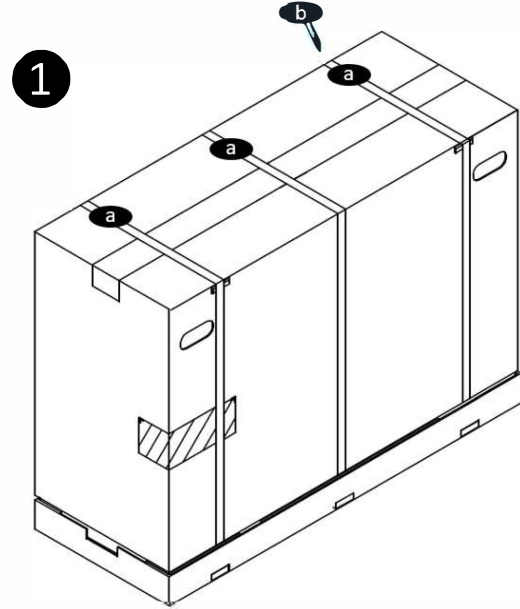

- a) Strap
- b) Strap Cutter
- c) Cardboard box
- d) Bottom Skid

- Cut all the straps (a) from the unit using strap cutter (b) as shown in figure.

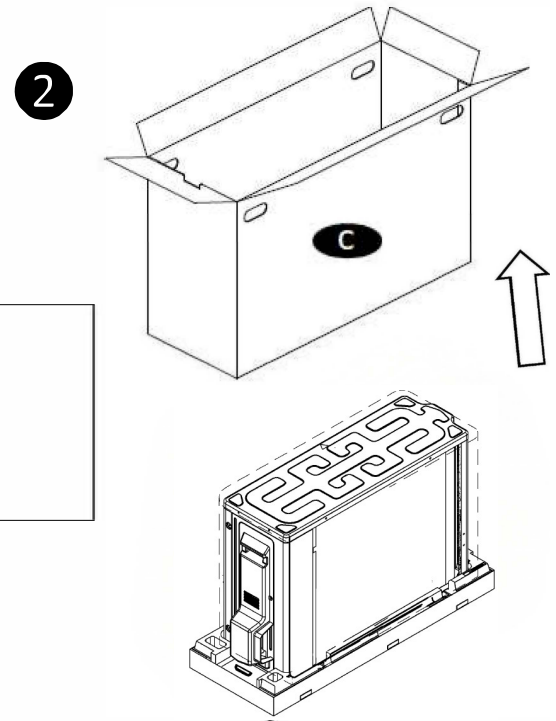

- Remove the cardboard box (c) from the unit after opening it and pulling it up as shown in figure.

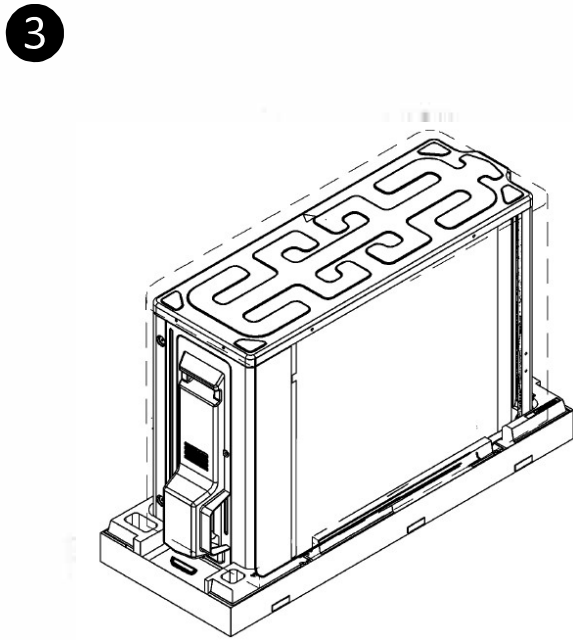

- Remove the bottom skid (d) with EPS by pulling the unit up, then remove the polythene product cover by pulling it up

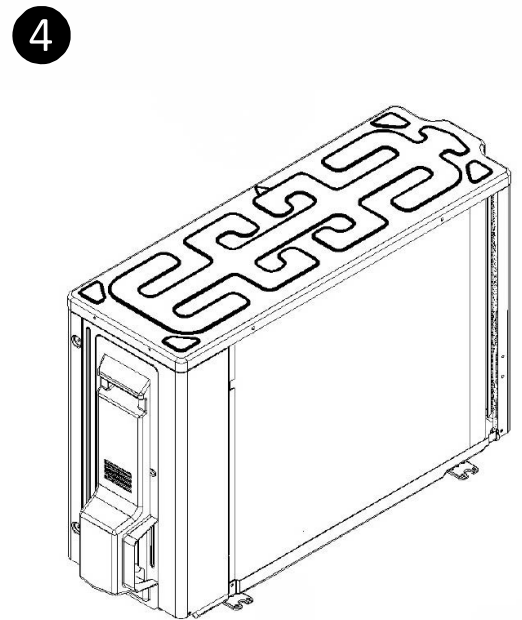

14-2 Packing

1

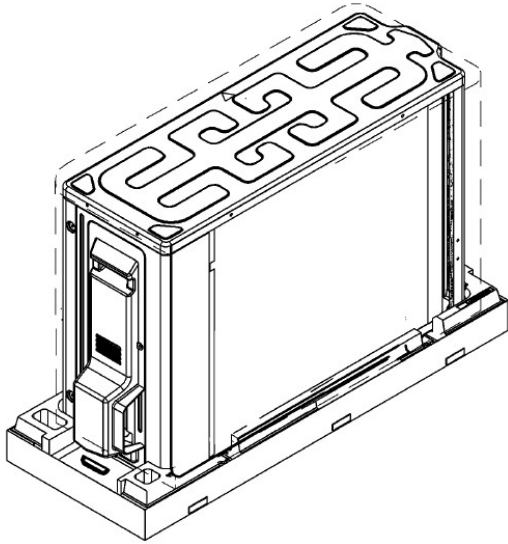

- Cover the unit with polythene product cover, then pick the unit up and settle it down on the bottom skid(d) as shown in figure.

2

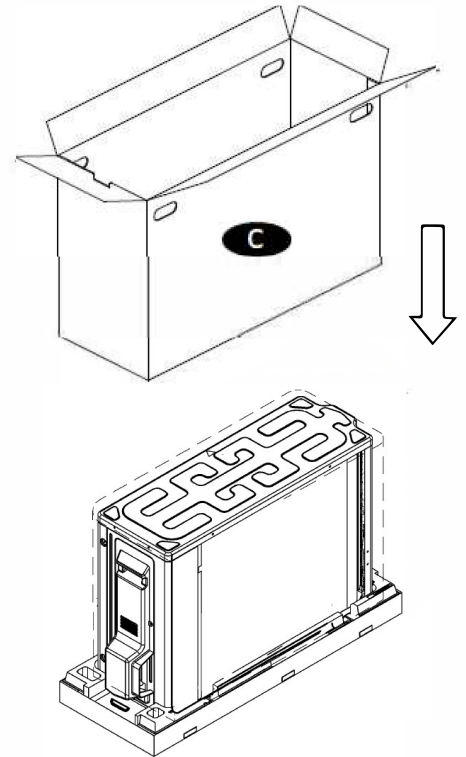

- a) Strap
- b) Starp Cutter
- c) Cardboard box
- d) Bottom Skid
- e) Portable strap fixing machine

- Put the cardboard box (c) upon the unit as shown in figure.

3

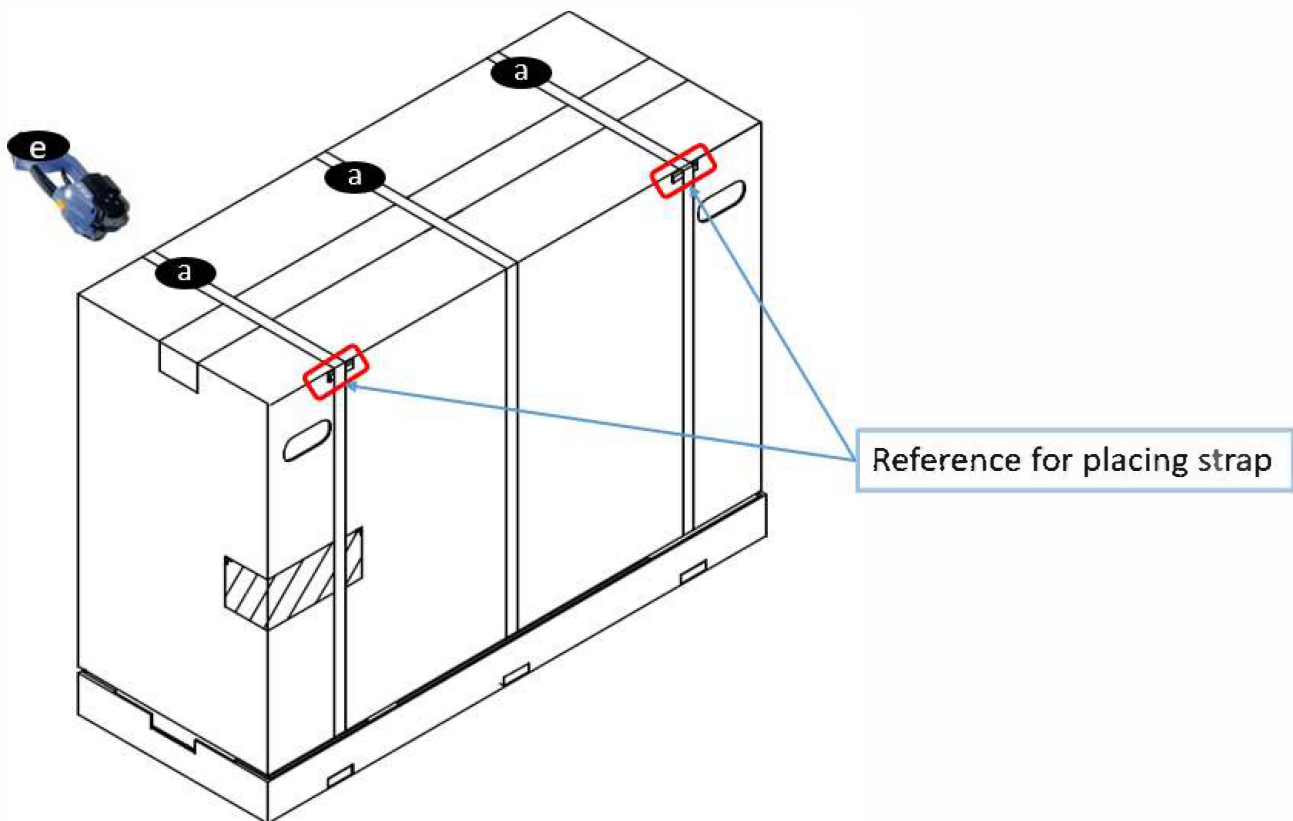

- Fix the straps (a) on the unit by using portable strap fixing machine as shown in figure.(Use marked reference for placing straps)



OPERATION MANUAL

SPLIT SYSTEM

Air Conditioners

MODELS

Ceiling Mounted Cassette type (Single Flow model)

FKCF71CRV16

Thank you for purchasing this product unit.
Carefully read this operation manual to ensure proper operation.

After reading the manual, file it away for future reference.

Furthermore, make certain that this operation manual is handed to a new user when he takes over the operation.

As this operation manual is dedicated for the indoor unit, refer to also the operation manuals attached to the outdoor unit and the remote controller.

■ DISPOSAL REQUIREMENTS



Disposal requirements

Your air conditioning product is marked with this symbol. This means that electrical and electronic products shall not be mixed with unsorted household waste.

Do not try to dismantle the system yourself: the dismantling of the air conditioning system, treatment of the refrigerant, of oil and of other parts must be done by a qualified installer in accordance with relevant local and national legislation.

Air conditioners must be treated at a specialized treatment facility for re-use, recycling and recovery. By ensuring this product is disposed of correctly, you will help to prevent potential negative consequences for the environment and human health. Please contact the installer or local authority for more information.

Batteries must be removed from the remote controller and disposed of separately in accordance with relevant local and national legislation.

CONTENTS

1. SAFETY PRECAUTIONS	39
2. WHAT TO DO BEFORE OPERATION	41
3. OPERATION RANGE	42
4. INSTALLATION SITE	42
5. OPERATION PROCEDURE	42
6. OPERATION CHARACTERISTICS	42
7. OPTIMUM OPERATION	44
8. MAINTENANCE (FOR SERVICE PERSONNEL)	44
9. AFTER-SALES SERVICE AND GUARANTEE REPAIR	45
10. NOT MALFUNCTION OF THE AIR CONDITIONER.....	46
11. TROUBLE SHOOTING	48
12.WIRING DIAGRAM.....	52
13.E-WASTE (GUIDELINES).....	54

Important information regarding the refrigerant used

This product contains fluorinated greenhouse gases covered by the Kyoto Protocol. Do not vent gases into the atmosphere.

Refrigerant type: R32

GWP⁽¹⁾ value: 675

⁽¹⁾GWP = global warming potential

The refrigerant quantity is indicated on the outdoor unit model name plate.

1. SAFETY PRECAUTIONS



Read the precautions in this manual carefully before operating the unit.

This appliance is filled with R32.

To gain full advantage of the air conditioner's functions and to avoid malfunction due to mishandling, please read this operation manual carefully before use.

This product comes under the term "appliances not accessible to the general public".

(Installation height of the air conditioner should be 2.7 to 3m.)

This appliance is intended to be used by expert or trained users in shops, in light industry and on farms, or for commercial use by lay persons.

This appliance can be used by children aged from 8 years and above and persons with reduced physical, sensory or mental capabilities or lack of experience and knowledge if they have been given supervision or instruction concerning use of the appliance in a safe way and understand the hazards involved. Children shall not play with the appliance. Cleaning and user maintenance shall only be done by service Person.

The appliance is not intended for use by unattended young children or persons who are incompetent to operate air conditioners.

It may result in injury or electric shocks.

- **This manual classifies the precautions into WARNINGS and CAUTIONS. Be sure to follow all the precautions below: They are all important for ensuring safety.**

⚠ WARNING..... Indicates a potentially hazardous situation which, if not avoided, could result in death or serious injury.

⚠ CAUTION..... Indicates a potentially hazardous situation which, if not avoided, may result in minor or moderate injury. It may also be used to alert against unsafe practices.

- **After reading, keep this manual in a convenient place so that you can refer to it whenever necessary. If the equipment is transferred to a new user, be sure also to hand over the manual.**



WARNING

Do not use means to accelerate the defrosting process or to clean, other than those recommended by the manufacturer.

The appliance must be stored in a room without continuously operating ignition sources (for example: open flames, an operating gas appliance or an operating electric heater).

Do not pierce or burn.

Be aware that refrigerants may not contain an odour.

Floor area required for installation of the equipment, refer to the installation manual of the outdoor unit.

When the air conditioner is malfunctioning (giving off a burning odour, etc.), stop the operation, turn off the power to the air conditioner and contact your local dealer.

Continued operation under such circumstances may result in a failure, electric shocks or a fire.

Consult your local dealer regarding modification, repair and maintenance of the air conditioner.

Improper workmanship may result in water leakage, electric shocks or a fire.

Be sure to use fuses with the correct ampere reading.

Do not use improper fuses, copper or other wiring as a substitute, as this may result in electric shocks, a fire, injury or damage to the air conditioner.

Consult your local dealer if the air conditioner submerges owing to a natural disaster, such as a flood or typhoon.

Do not operate the air conditioner in that case, or otherwise a malfunction, electric shocks, or a fire may result.

Start or stop the air conditioner with the remote controller. Never use the power circuit breaker for this purpose.

Otherwise, it may cause a fire or water leakage. Furthermore, if an automatic restart control is provided against power failure and the power is recovered, the fan will rotate suddenly and may cause injury.

Do not use the air conditioner in the atmosphere contaminated with oil vapour, such as cooking oil or machine oil vapour.

Oil vapour may cause crack damage to the air conditioner, electric shocks, or a fire.

Do not use flammable materials (e.g., hairspray or insecticide) near the air conditioner.
Do not clean the air conditioner with organic solvents such as paint thinner.

The use of organic solvents may cause crack damage to the air conditioner, electric shocks, or a fire.

Do not use the air conditioner in places with excessive oily smoke, such as cooking rooms, or in places with flammable gas, corrosive gas, or metal dust.

Using the air conditioner in such places may cause a fire or air conditioner failures.

Beware of a fire in case of refrigerant leakage.

If the air conditioner is not operating correctly, i.e. not generating cool or warm air, refrigerant leakage could be the cause. Consult your local dealer for assistance. The refrigerant used for the air conditioner is safe and normally does not leak. However, if the refrigerant leaks and gets in contact with a naked burner, heater or cooker, it may generate hazardous compounds. Turn off the air conditioner and call your local dealer. Turn on the air conditioner after the qualified service person makes sure to confirm that the leakage is repaired.

Do not place objects, including rods, your fingers, etc., in the air inlet or outlet.

Injury may result due to contact with the air conditioner's highspeed fan blades.

Consult your local dealer regarding cleaning the inside of the air conditioner.

Improper cleaning may cause breakage of plastic parts, water leakage and other damage as well as electric shocks.

Be aware that prolonged, direct exposure to cool or warm air from the air conditioner, or to air that is too cool or too warm can be harmful to your physical condition and health.

Consult your local dealer about installation work.

Doing the work yourself may result in water leakage, electric shocks or a fire.

Contact professional personnel about attachment of accessories and be sure to use only accessories specified by the manufacturer.

If a defect results from your own workmanship, it may result in water leakage, electric shocks or a fire.

Consult your local dealer regarding relocation and reinstallation of the air conditioner.

Improper installation work may result in leakage, electric shocks or a fire.

Be sure to earth the air conditioner.

Do not earth the air conditioner to a utility piping, lightning conductor or telephone earth lead.

Imperfect earthing may result in electric shocks or a fire. A high surge current from lightning or other sources may cause damage to the air conditioner.

Be sure to install an earth leakage breaker.

Failure to install an earth leakage breaker may result in electric shocks or a fire.

Be sure to use a dedicated power supply for the air conditioner.

The use of any other power supply may cause heat generation, a fire, or air conditioner failures.

Consult your local dealer regarding what to do in case of refrigerant leakage.

When the air conditioner is installed in a small room, it is necessary to take proper measures so that the amount of any leaked refrigerant does not exceed the concentration limit in the event of a leakage. Otherwise, this may lead to an accident due to oxygen depletion.

CAUTION

Children should be watched so that they do not play with the indoor unit or its remote controller.

Accidental operation by a child may result in injury or electric shocks.

Do not allow a child to mount on the outdoor unit or avoid placing any object on it.

Falling or tumbling may result in injury.

Do not let children play on or around the outdoor unit.

If they touch the outdoor unit carelessly, injury may be caused.

Be sure that children, plants or animals are not exposed directly to airflow from the indoor unit, as adverse effects may ensue.

Do not place flammable sprays or operate spray containers near the air conditioner as this may result in a fire.

Do not wash the air conditioner or the remote controller with water, as this may result in electric shocks or fire.

Do not place water containers (flower vases, etc.) on the indoor unit, as this may result in electric shocks or a fire.

Do not put flammable containers, such as spray cans, within 1 m from the air outlet.

The containers may explode because the warm air from the indoor or outdoor unit will affect them.

Turn off the power when the air conditioner is not used for long periods of time.

Otherwise, the air conditioner may get hot or catch on a fire due to dust accumulation.

Do not place objects in direct proximity of the outdoor unit and do not let leaves and other debris accumulate around the outdoor unit.

Leaves are a hotbed for small animals which can enter the outdoor unit. Once in the outdoor unit, such animals can cause malfunctions, smoke or a fire when making contact with electrical parts.

Before cleaning, be sure to stop the air conditioner operation, turn the power circuit breaker off.

Otherwise, an electric shocks and injury may result.

To avoid electric shocks, do not operate with wet hands.

Never touch the internal parts of the remote controller.

Touching certain internal parts will cause electric shocks and damage to the remote controller. Consult your local dealer about checking and adjustment of internal parts.

To avoid oxygen deficiency, ensure that the room is adequately ventilated if equipment such as a burner is used together with the air conditioner.

Do not leave the remote controller wherever there is a risk of wetting.

If water gets into the remote controller there is a risk of electrical leakage and damage to electronic components.

Watch your steps at the time of air filter cleaning or inspection.

High-place work is required, to which utmost attention must be paid.

If the scaffold is unstable, you may fall or topple down, thus causing injury.

Do not remove the outdoor unit's outlet side grille. The grille protects against the outdoor unit's high speed fan, which may cause injury.

To avoid injury, do not touch the air inlet or aluminum fins of the air conditioner.

Do not place objects that are susceptible to moisture directly beneath the indoor or outdoor units.

Under certain conditions, condensation on the outdoor unit or refrigerant piping, air filter dirt or drain blockage may cause dripping, resulting in fouling or failure of the object concerned.

Do not place heaters directly below the indoor unit, as resulting heat can cause deformation.

Do not place appliances that produce naked flames in places exposed to the airflow from the air conditioner as this may impair combustion of the burner.

Do not block air inlets nor outlets.

Impaired airflow may result in insufficient performance or trouble.

Do not use the air conditioner for purposes other than those for which it is intended.

Do not use the air conditioner for cooling precision instruments, food, plants, animals or works of art as this may adversely affect the performance, quality and/or longevity of the object concerned.

Do not install the air conditioner at any place where there is a danger of flammable gas leakage.

In the event of a gas leakage, build-up of gas near the air conditioner may result in a fire.

Carry out drain piping properly to ensure complete drainage.

If drain piping is not carried out properly, drain will not flow out. Then, dirt and debris may be accumulated in the drain piping and may cause water leakage. If it occurs, stop the air conditioner and call your local dealer for assistance.

2. WHAT TO DO BEFORE OPERATION

This operation manual is for the following systems with standard control. Before initiating operation, contact your local dealer for the operation that corresponds to your system.

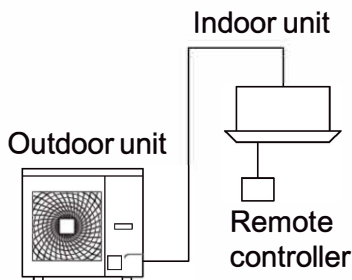

NOTE

- Read the operation manual attached to the remote controller you are using.

When using a wireless remote controller, refer to the operation manual attached to the wireless remote controller kit.

If your installation has a customized control system, ask your local dealer for the operation that corresponds to your system.

• Heat pump type

This system provides COOLING, HEATING, AUTOMATIC, PROGRAM DRY, and FAN OPERATION modes.

PRECAUTIONS FOR GROUP CONTROL SYSTEM OR TWO REMOTE CONTROLLERS CONTROL SYSTEM

This system provides two other control systems beside individual control (one remote controller controls one indoor unit) system. Confirm the following if your unit is the following control system type.

• Group control system

One remote controller controls up to 16 indoor units.

All indoor units are equally set.

Each indoor unit uses its respective intake air temperature sensor to individually control the temperature according to the set temperature on the remote controller.

• Two remote controllers control system

Two remote controllers control one indoor unit (In case of group control system, one group of indoor units).

NOTE

- Contact your local dealer in case of changing the combination or setting of group control and two remote controller control systems.
- Please do not change the combination and settings for the group operation and two remote controllers control systems by yourself, but be sure to ask your local dealer.

Names and functions of parts

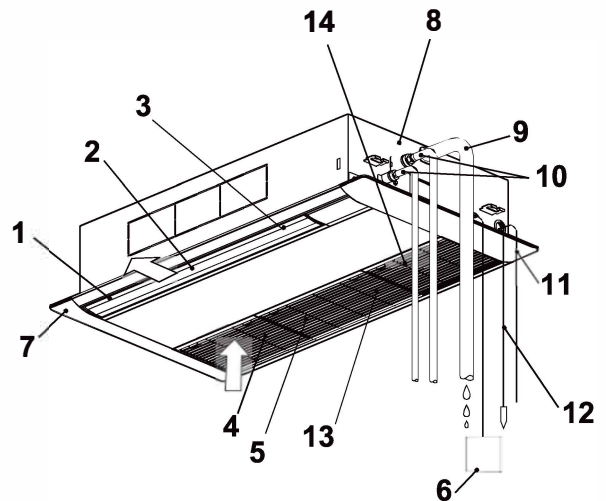

1	Air outlet The airflow rate can be set to "Auto" or one of 3 levels via the remote controller.
2	Horizontal blade (inside air outlet) The up/down airflow direction can be set to "Auto Swing", or one of 5 directions via the remote controller.
3	Vertical blade (inside air outlet) The Left/Right airflow direction can be set to "Auto Swing", or default position via the remote controller.
4	Suction grille (Refer to "8. MAINTENANCE" on page8.)
5	Air filter (inside suction grille) (Refer to "8. MAINTENANCE" on page8.)
6	Remote controller (optional accessory) Read the operation manual attached to the remote controller for instructions on its use. A remote controller may not be needed de-pending on the system configuration.
7	Decoration panel (optional accessory)
8	Drain discharge device (built-in part) Discharges the indoor moisture removed during COOLING operation.

9	Drain piping
10	Refrigerant piping
11	Transmission wiring
12	Earth wiring (NOTE) It is wiring to let electricity flow from the indoor unit to the earth for prevention of electric shocks / a fire in case of emergency.
13	Indoor unit model nameplate (inside suction grille) Lists the indoor unit model name and other related information.
14	Decoration panel model nameplate (inside suction grille) Lists the decoration panel model name and other related information.

(*1) With an installed sensor kit (optional accessory)

3. OPERATION RANGE

If the temperature or the humidity is beyond the following conditions, safety devices may work and the air conditioner may not operate, or sometimes, water may drop from the indoor unit.

COOLING [°C]

OUTDOOR UNIT	INDOOR		OUTDOOR TEMPERATURE
	TEMPERATURE	HUMIDITY	
RZFC71CRV16	DB	19 to 35	DB 21 to 52
	WB	14 to 24	

HEATING			
OUTDOOR UNIT	INDOOR TEMPERATURE		OUTDOOR TEMPERATURE
RZFC71CRV16	D B	10 to 27	D B -10 to 24
			W B -10 to 18

* To avoid condensation and water dripping out the indoor unit. DB: Dry bulb temperature
WB: Wet bulb temperature
The setting temperature range of the remote controller is as follows.

Cooling operation: 16 to 32°C

4. INSTALLATION SITE

Regarding places for installation

- **Is the air conditioner installed at a well-ventilated place where there are no obstacles around?**
- **Do not use the air conditioner in the following places.**
 - Filled with much mineral oil such as cutting oil
 - Where there is much salt such as a beach area
 - Where sulfured gas exists such as a hot-spring resort
 - Where there are considerable voltage fluctuations such as a factory or plant
 - Vehicles and vessels
 - Where there is much spray of oil and vapor such as a cookery, etc.
 - Where there are machines generating electromagnetic waves
 - Filled with acid and/or alkaline steam or vapor
- **Is a snow protection measure taken?**
For details, consult your dealer about snow protection hoods, etc.

Regarding wiring

- **All wiring must be performed by an authorized electrician.**
To do wiring, ask your dealer. Never do it by yourself.
- **Make sure that a separate power supply circuit is provided for this air conditioner and that all electrical work is carried out by qualified personnel according to local laws and regulations.**

Pay attention to running noises, too

- **Are the following places selected?**
 - A place that can sufficiently withstand the weight of the air conditioner with less running noises and vibrations.
 - A place where the hot wind discharged from the air outlet of the outdoor unit and the running noises do not cause a nuisance to neighbours.
- **Are you sure that there are no obstacles near the air outlet of the outdoor unit?**
Such obstacles may result in declined performance and increased running noises.
- **If abnormal noises occur in use, stop the operation of the air conditioner, consult your dealer.**

System relocation

- **Consult your Daikin dealer about remodelling and relocation.**

Regarding drainage of drain pipe

- **Is the drain pipe executed to perform complete drainage?**
If proper drainage is not carried out from the outdoor drain pipes during air-conditioning operation, chances are that dust and dirt are clogged in the pipe. This may result in a water leakage from the indoor unit. Under such circumstances, stop the operation of the air conditioner, and then consult your dealer or our service station.

5. OPERATION PROCEDURE

- **Operation procedure**
Read the operation manual attached to the remote controller.
- **Operation procedure varies with heat pump type and cooling only type.** Contact your local dealer to confirm your system type.
- **To protect the unit, turn on the main power supply switch 6 hours before operation.**
- **Do not shut off the power supply during seasonal use of the air conditioner.**
This is required in order to activate the air conditioner smoothly.
- **If the main power supply switch is turned off during operation, operation will restart automatically after the power turns back on again.**

6. OPERATION CHARACTERISTICS

- **CHARACTERISTICS OF THE COOLING OPERATION (COOLING OPERATION AND AUTOMATIC COOLING OPERATION)**
- **When operating continuously at downward airflow direction, air blows in the automatically set direction for a period of time to prevent condensation on the horizontal blade.** (The remote controller displays the airflow direction that is set.)
- **If the COOLING OPERATION is used when the indoor temperature is low, frost forms on the heat exchanger of the indoor unit.** This can decrease the cooling capacity.
- **When the outdoor temperature is high, it takes some time until the indoor temperature reaches the set temperature.**

■ CHARACTERISTICS OF THE HEATING OPERATION (HEATING OPERATION AND AUTOMATIC HEATING OPERATION)

START OF OPERATION

- It generally takes a longer time for indoor temperature of the HEATING OPERATION to reach the set temperature compared to the COOLING OPERATION. It is advisable to start operation in advance using the TIMER OPERATION.

Perform the following operation to prevent heating capacity decrease and discharge of cool air.

AT THE START OF OPERATION AND AFTER THE DEFROST OPERATION

- A warm air circulating system is employed, and therefore it takes some time until the entire room is warmed up after the start of operation.
- The indoor fan runs to discharge a gentle wind automatically until the temperature inside the air conditioner reaches a certain level. At this time, the remote controller displays “”. Leave it as it stands and wait for a while.
(The remote controller displays the fan speed that is set.)

DEFROST OPERATION

(Frost removal operation for the outdoor unit)

- As the frost on the coil of an outdoor unit increase, heating effect decreases and the air conditioner goes into the DEFROST OPERATION.
- The indoor unit fan stops and the remote controller display shows “”.
With the wireless remote controller, the warm air stops, and the DEFROST OPERATION lamp on the light receiving unit turn on. (The remote controller displays the fan speed that is set.)
- After maximum 10 minutes of the DEFROST OPERATION, the air conditioner returns to the HEATING OPERATION.
- During or after the DEFROST OPERATION, white mist comes out from the air inlet or outlet of the air conditioner.
(Refer to 4. on page 7.)
- A hissing and “Shuh” sound may be heard during this particular operation.

Regarding outside air temperature and heating capacity

- The heating capacity of the air conditioner declines as the outside air temperature falls. In such a case, use the air conditioner in combination with other heating systems. (When a combustion appliance is used, ventilate the room regularly.)
Do not use the combustion appliance where the air from the air conditioner is blown directly toward it.
- When the warm air stays under the ceiling and your feet are cold, we recommend that you use a circulator (a fan to circulate the air inside the room). For details, consult your local dealer.
- When the indoor temperature exceeds the set temperature, the indoor unit discharges a gentle breeze (switches to gentle wind). (The remote controller displays the fan speed that is set.)

■ CHARACTERISTICS OF THE PROGRAM DRY OPERATION

- This operation lowers the humidity without lowering the indoor temperature. The indoor temperature when the operation button is pressed will be the set temperature. At this time, the fan speed and temperature are set automatically, so the remote controller does not display the fan speed and set temperature.
To efficiently lower the indoor temperature and humidity, first use the COOLING OPERATION to lower the indoor temperature, and then use the PROGRAM DRY OPERATION. When the indoor temperature is lowered, airflow from the air conditioner may stop.
- If the PROGRAM DRY OPERATION is used when the indoor temperature is low, frost forms the heat exchanger of the indoor unit. In this case, the air conditioner automatically switches to the DEFROST OPERATION for a while.
The low fan speed or a gentle wind is used to prevent the discharge of melt water.

■ AIRFLOW DIRECTION ADJUST

There are 5 settings available with wired remote and 1 setting with wireless remote available for adjusting airflow direction.

(The horizontal blade of the air outlet is closed when the indoor unit is stopped)

Swing

Airflow direction swing up and down automatically.

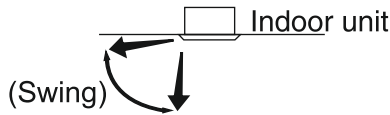

Fixed

Airflow direction can be fixed to only default position.

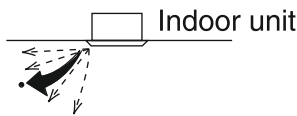

MOVEMENT OF THE HORIZONTAL BLADE

For the following conditions, micro computer controls the airflow direction so it may be different from the display.

Operation mode	<ul style="list-style-type: none"> • COOLING , HEATING • AUTOMATIC • PROGRAM DRY • FAN OPERATION
Up and down direction	<ul style="list-style-type: none"> • When operating continuously at horizontal airflow direction (Air blows in the automatically set direction for a period of time to prevent condensation on the horizontal blades.)

7. OPTIMUM OPERATION

Observe the following precautions to ensure the system operates.

- Adjust the room temperature properly for a comfortable environment. Avoid excessive cooling.
- Prevent direct sunlight from entering a room during cooling operation by using curtains or blinds.
- Keep doors and windows closed. If the doors and windows remain open, room air will flow out and cause to decrease the effect of cooling.
- Never place objects near the air inlet and the air outlet of the unit. It may cause deterioration in the effect or stop in the operation.
- Install TV, radios, and stereos 1 m or more away from the indoor unit and remote controller. Images may become fuzzy and noise may be generated.

- Turn off the main power supply switch when it is not used for long period of time. When the main power supply switch is turned on, some watts of electricity is being used even if the system is not operating. (*1)
Turn off the main power supply switch for saving energy. When reoperating, turn on the main power supply switch 6 hours before operation for smooth running (Refer to "8 . MAINTENANCE" on page 8).(*2)
*1 The consumed power while the outdoor unit is not in operation depends on the model.
*2 The setting before the power circuit breaker is cut off is stored. (The timer setting is cleared.)
- When the display shows "TIME TO CLEAN AIR FILTER" ask a qualified service person to clean the filter (Refer to "8 . MAINTENANCE" on page 8).(*2)
- Fully use the function of air flow direction adjust. Cold air gathers on the floor. Set the air direction to horizontal during the COOLING . Do not let the air blow directly to a person.
- It takes time for the room temperature to reach the set temperature. We recommend starting the operation in advance using timer operation.

8.MAINTENANCE (FOR SERVICE PERSONNEL)

! Warning

- Only the professional service person can perform maintenance work.
- Turn off all power supply before contacting with the wiring devices.
- Do not use flammable materials (e.g., hairspray or insecticide) near the product.
- Do not clean the product with organic solvents such as paint thinner. Using the organic solvents may result in cracks, electric shocks or fire hazards.
- Ask the technical expertise to install the optional accessories.
- Be use to use the specified accessories by Daikin. Improper installation by yourself may result in water leakage, electric shocks and fire hazards.

! CAUTION

- Only proceed with the unit cleaning after stopping the operation and turning the power supply off. Failure to do so may result in electric shocks or personal injury.

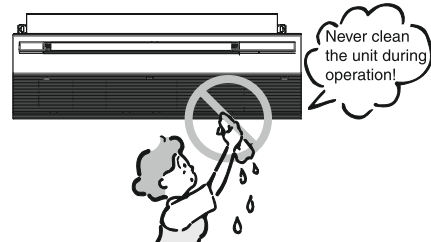

- Don't wash the air conditioner with water. Failure to do so may result in electric shocks.

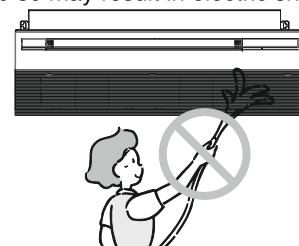

- Use stable stand. Pay special caution when cleaning the air conditioner.

9. HOW TO CHECK THE INITIAL SET VALUE

Further question regarding to the available functions, contact your local dealer with your initial setting value confirmed by using the remote controller with the following steps.



Press the **INSPECTION** button to select the inspection mode “”.



Press the () button 2 times to return to normal operation mode.

For installation

1. SAFETY PRECAUTIONS

Please read these “SAFETY PRECAUTIONS” carefully before installing air conditioning equipment and be sure to install it correctly.

This manual classifies the precautions into WARNINGS and CAUTIONS.

Be sure to follow all the precautions below. They are all important for ensuring safety.

WARNING Indicates a potentially hazardous situation which, if not avoided, could result in death or serious injury.

CAUTION Indicates a potentially hazardous situation which, if not avoided, may result in minor or moderate injury. It may also be used to alert against unsafe practices.

After the installation is completed, test the air conditioner and check if the air conditioner operates properly. Give the user adequate instructions concerning the use and cleaning of the indoor unit according to the operation manual. Ask the user to keep this manual in a handy place for future reference.

WARNING

- Make sure to turn off the power supply before starting the installation.
- Due to high voltage, do not open control box lid for ten minutes after the safety breaker is switched off.
- Do not touch live parts when carrying out this work.

CAUTION

- Refer also to the installation manual attached to the indoor unit.
- Confirm that following conditions are satisfied prior to installation.
 - Ensure that nothing interrupts the operation of the wireless remote controller. (Ensure that there is neither a source of light nor fluorescent lamp near the receiver. Also, ensure that the receiver is not exposed of direct sunlight.)
 - Ensure that the operation indicator lamp and other indicators are easy to see.
- The wireless remote controller kit is not intended for use in a potentially explosive atmosphere.

2. BEFORE INSTALLATION

2-1 ACCESSORIES

Check if the following accessories are attached to this kit.

Name	(1) Wireless remote controller	
Quantity	1 pc.	
Shape		

2-2 NOTE TO THE INSTALLER

- Have the customer actually operate the system while looking at the operation manual. Instruct the customer how to operate the system.

3. REMOTE CONTROLLER INSTALLATION

<Installing wireless remote controller>

- Do not throw the remote controller or impose large shocks. Also, do not store where it may be exposed to moisture or direct sunlight.
- When operating, point the transmitting part of the remote controller in the direction of the receiver. (Refer to the operation manual (3) attached to this kit.)
- The maximum transmitting distance is 5 m. This depends on the installation condition of the indoor unit.
- The signal cannot be transmitted if something such as curtains blocks the receiver and the remote controller.
- **Loading the batteries**
 1. Slide the back cover and remove it.
 2. Insert the dry cell battery AAA, LR03 (alkaline) (2). Properly insert, set the batteries by matching the (+) and (-) polarity marks as indicated.
 3. Insert the back cover again.

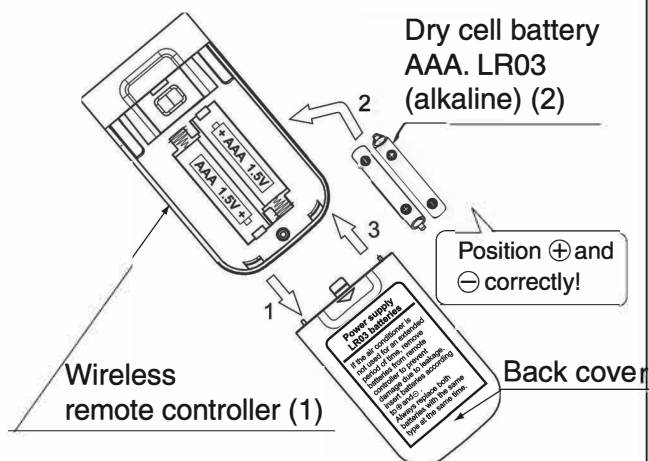

Fig. 1

4. INITIAL SETTING

Available functions on this remote controllers are differ according to the indoor unit type applied. Refer to the installation manual attached to the Wireless Receiver Kit and conduct initial setting according to the combination of the indoor unit.

<HOW TO CHECK THE INITIAL SET VALUE>

- (1) Press the button to select the the inspection mode “”.

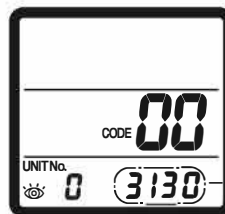

- (2) Press the button 2 times to return to normal operation mode.

<HOW TO SET THE INITIAL SET VALUE>

1. Change the set value: Press the button change the blinking digit.
2. Determine the set value: Press the button to determine the blinking digit and move to the right digit.

Press the button to move to the left digit.

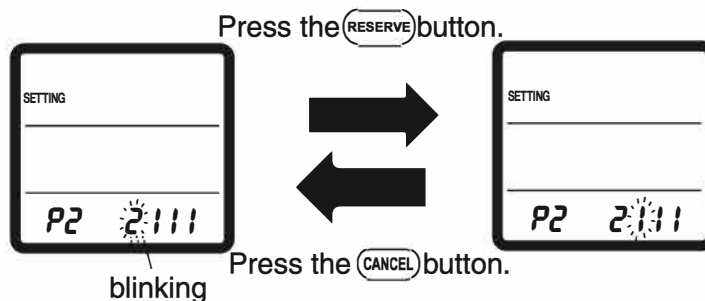

- 3) The initial set value is determined when the digit at the far right is determined. Then become to normal mode display.

If the current initial setting needs to be re-set, insert the battery while pressing the



lower button and the button.

After a few seconds of pressing, the initial setting indication is displayed.

Daily maintenance: Cleaning the air filter

Description

- Do not remove the air filter if not going to clean it. Failure to do so may result in malfunction.
- When "Filter cleaning" is indicated on the remote controller or on the centralized controller, clean the air filter.
- This will be displayed after running a certain period of time.
- If the air conditioner is used in a dusty place, increase the frequency of cleaning. (About once every half year)

1. Suction Grille.

Push backward to all the three locks gently, pull slowly suction grille at an angle 35 - 45 degree and pull outward.

CAUTION Do not loosen your grip immediately after pushing to the top. Failure to do so will result in personnel injury as the Suction Grille will fall off under the action of its own gravity.

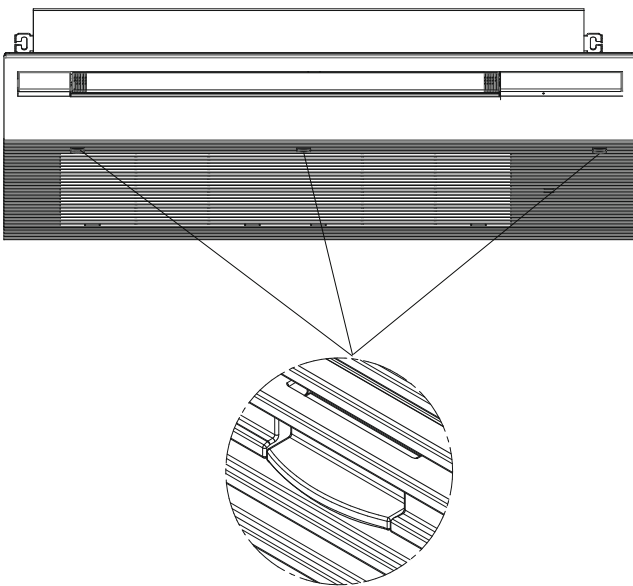

3 sliding lock for suction grille

2. After opening the suction grille, remove the air filter as shown in the figure below.

- 1) Push the air filter till the end, then pull the air filter upward slowly to remove one piece of them.
- 2) Proceed with the same method as (1) to remove the second piece of air filter.

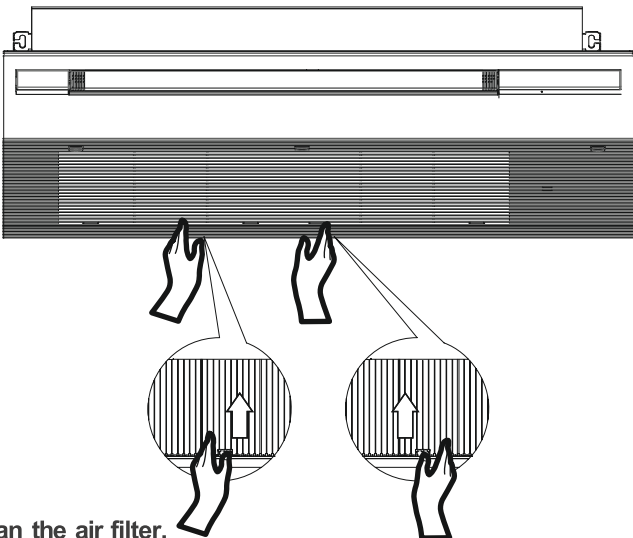

3. Clean the air filter.

Caution

- Do not use the hot water with temperature higher than 50 °C, to prevent from fading or being deformed.
- Do not dry the air filter by a fire as it may catch fire.

- Ⓐ Use a dust collector or Ⓑ wash with the water to remove the dust.
- Ⓐ Use a dust collector to remove the dust.

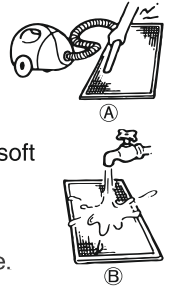

- Ⓑ Wash with the water.
If there is too much dust, wash it with a soft brush and the neutral detergent.



Throw off the water and dry in a shade place.

4. Install air filter.

After opening the suction grille, put the two pieces of air filter in to the suction grille hook, and push them against the lock to fix the air filter

- 5. After turning on the power supply, press the "filter cleaning signal resetting" key. The display of "Filter cleaning" will disappear. Cleaning the air outlet and the outer panel

Caution

- Do not use gasoline, benzene, thinner, polishing powder or liquid insecticide.
- Do not use the hot water with temperature higher than 50 °C. Failure to do so will result in fading or being deformed.
- Wipe with a soft dry cloth.
- If it is unable to remove the dust, use the water or the neutral detergent.

10. AFTER-SALES SERVICE AND GUARANTEE REPAIR

Warning

- Ask the professional service person to make repairs. Improper repairs may result in water leakage, electric shocks and fire hazards. Always ask the professional service person for removing and reinstalling.
- Improper installation may result in water leakage, electric shocks and fire hazards.
- The refrigerant within the air conditioner is safe.
- Generally, it is unlikely to leak. However, in case of a refrigerant leakage in the rooms, it may generate harmful gas if in contact with the fire of a warmer, stove and furnace.
- After completing refrigerant leakage repair work, don't operate the air conditioner until a service person confirms that the leakage has been repaired.
- When calling for repair, inform your dealer of the details as follows:
 - Model name
 - Serial number and installation date
 - Malfunction - details (Malfunction code displayed on the remote controller.)
 - Your name, address and telephone number
- When the warranty term is expired Contact the dealer and if able to repair, pay service will be available.
- Minimum storage period of key components and parts Daikin will have the key components and parts in stock for 9 years at least after discontinuing the production of this type of air conditioner. The key components and parts mean parts essential for the operation of air conditioner.

- Maintenance and inspection
After years of operation, accumulated dust will more or less impair the unit's performance.
We advise you to enter a maintenance and inspection contract (pay service) in addition to a normal maintenance performed by yourself. For details about the professional service, contact your dealer.
- Where to call
For after-sales service, etc., consult with your dealer.
- Recover the refrigerant first before unit's discard, transport, reset and maintenance. The unit to be discarded should be handled by the recycle with qualification of dealing with the wasted electrical appliance and electronic products.
- For each homogeneous material of the air conditioner, contents of the lead, mercury, hexavalent chromium, PBB and PBDE are lower than 0.1 % (mass fraction), and content of the cadmium is lower than 0.01 % (mass fraction).

11. NOT MALFUNCTION OF THE AIR CONDITIONER

The following symptoms do not indicate air conditioner malfunction

- **HEATING OPERATION** within 6 hours after the power is supplied to the air conditioner.
Some models perform the following operation to protect the devices.

If the **HEATING OPERATION** is performed within 6 hours after the power is supplied to the air conditioner, the indoor fan stops for about 10 minutes during the outdoor unit operation to protect the devices.

The above operation is performed not only at the time of installation, but every time the power circuit breaker is turned off/on.

For comfort heating, it is recommended not to turn off the power circuit breaker during the **HEATING OPERATION**.

1. THE AIR CONDITIONER DOES NOT OPERATE

- **The air conditioner does not restart immediately after the ON/OFF button is pressed.**
- **The air conditioner does not restart immediately when TEMPERATURE SETTING button is returned to the former position after pushing the button.**
If the OPERATION lamp lights, the air conditioner is in normal condition.
It does not restart immediately because a safety device operates to prevent overload of the air conditioner.
After approx. 3 minutes, the air conditioner will turn on again automatically.
- **The air conditioner does not start when the display shows “  ” and it flashes for few seconds after pressing an operation button.**

This is because the air conditioner is under centralized control.

Flashes on the display indicates that the air conditioner cannot be controlled by the remote controller.

- **HEATING OPERATION** within 6 hours after the power is supplied to the air conditioner.

Some models perform the following operation to protect the devices.

If the **HEATING OPERATION** is performed within 6 hours after the power is supplied to the air conditioner, the indoor fan stops for about 10 minutes during the outdoor unit operation to protect the devices.

The above operation is performed not only at the time of installation, but every time the power circuit breaker is turned off/on. For comfortable use, do not turn off the power circuit breaker during seasonal use of the HEATING OPERATION.

- **The outdoor unit stops.**

This is because the indoor temperature has reached the set temperature.

The indoor unit is in the FAN OPERATION.

COOLING OPERATION

(AUTOMATIC COOLING OPERATION):

Lower the set temperature.

HEATING OPERATION

(AUTOMATIC HEATING OPERATION):

Raise the set temperature.

The operation starts after a while when the air conditioner is in normal condition.

- **The remote controller displays “”, and airflow stops.**

This is because the air conditioner automatically switches to the DEFROST OPERATION to prevent a decrease in heating capacity when frost on the outdoor unit increases.

After maximum 10 minutes, the air conditioner returns to its original operation.

2. THE OPERATION SOMETIMES STOPS

- **The remote controller displays “U4” and “U5”, and the operation stops. However, it will restart in a few minutes.**

This is because communication between the indoor and outdoor units or indoor units and remote controllers is shut off and stops the operation due to noise caused by devices other than the air conditioner.

When the electrical noise decreases, the air conditioner automatically restarts.

3. THE FAN SPEED IS DIFFERENT FROM THE SETTING

- **Pressing the fan speed control button does not change the fan speed.**

During the COOLING OPERATION, the low fan speed or a gentle wind is used to prevent the discharge of melt water.

During the DEFROST OPERATION (HEATING OPERATION), the wind from the air conditioner stops to prevent air discharge directly toward your body.

After a while, the fan speed can be changed. (The fan speed cannot be set for the PROGRAM DRY OPERATION.)

When the room temperature reaches the set temperature during the HEATING OPERATION, the outdoor unit stops and the indoor unit goes into gentle wind.

It takes some time until the fan speed changes. Raise the set temperature. After a while, the fan speed changes.

4. WHITE MIST COMES OUT OF THE AIR CONDITIONER

- **When humidity is high during the COOLING OPERATION (In oily or dusty places)**

If the inside of an indoor unit is extremely contaminated, the temperature distribution inside a room becomes uneven. It is necessary to clean the inside of the indoor unit.

Ask your local dealer for details on cleaning the indoor unit.

This cleaning requires a qualified service person.

Check the usage environment.

- **When the air conditioner is changed over to the HEATING OPERATION after the DEFROST OPERATION and in the DEFROST OPERATION.**

Moisture generated by defrost becomes steam and will float around.

When the remote controller display shows “”, DEFROST OPERATION is being used.

5. NOISE OF AIR CONDITIONERS

- **A low continuous flow “Shuh” sound which is heard when the air conditioner is in the COOLING or DEFROST OPERATION or a trickling sound which is heard when the air conditioner is in the DEFROST OPERATION.**

This is the sound of refrigerant gas flowing through both indoor and outdoor units.

- **A “Shuh” sound which is heard at the start or immediately after the stop of operation or which is heard at the start or immediately after the stop of the DEFROST OPERATION.**

This is the noise of refrigerant caused by flow stop and flow change.

During the HEATING OPERATION, the air conditioner switches to the DEFROST OPERATION automatically.

The remote controller shows “”.

After maximum 10 minutes, the air conditioner returns to its original operation.

- **A “Pishi-pishi” squeaking sound is heard when the air conditioner is in operation or after the stop of operation.**

Expansion and contraction of resin parts caused by temperature change makes this noise.

6. DUST FROM THE INDOOR UNITS

- **Dust may blow out from the unit after starting operation from long resting time.**
Dust absorbed by the unit blows out.

7. THE INDOOR UNITS GIVE OFF ODOURS

- **During operation**
The unit absorbs the smell of rooms, furniture, cigarettes, etc., and then emits them.
If odour is a concern, you can set to zero fan speed when the indoor temperature reaches the set temperature.
For details, contact your local dealer.

8. THE AIR CONDITIONER DOES NOT COOL EFFECTIVELY

- **The air conditioner is operating in the PROGRAM DRY OPERATION.**
This is because program dry mode operates so that the indoor temperature decreases as little as possible.
Lower the indoor temperature using the COOLING OPERATION, and then use the PROGRAM DRY OPERATION.
(Refer to **CHARACTERISTICS OF THE PROGRAM DRY OPERATION** on page 7.)
- **Read through characteristics of the COOLING OPERATION, characteristics of the HEATING OPERATION, and characteristics of the PROGRAM DRY OPERATION on page 7.**

12. TROUBLE SHOOTING

Please check before requesting a service.

1. If the air conditioner does not operate at all.

- Check if fuse has blown.
Turn off the power supply.
- Check if the power circuit breaker is blown.
If the tab of power circuit breaker is in the OFF position, turn the power on with the power circuit breaker switch.
If the tab of power circuit breaker is in the trip position do not turn the power on with the power circuit breaker switch.
Contact your local dealer.

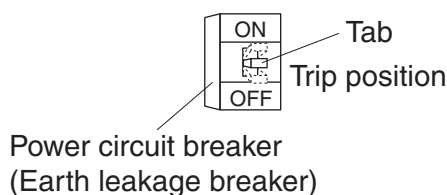

- Check if there is a power failure.
Wait until power is restored. If power failure occurs during operation, the air conditioner automatically restarts immediately after the power supply recovers.

2. If the air conditioner stops after operating the air conditioner.

- Check if the air inlet or outlet of outdoor or indoor unit is blocked by obstacles.
Remove the obstacle and make it well-ventilated.
- Check if the air filter is clogged.
Ask a qualified service person to clean the air filters.
A decrease in the airflow volume of the air conditioner will result and the performance of the air conditioner will be degraded and power consumption will increase if the air filter is clogged with dust or dirt.
In addition, this may cause dew condensation at the air outlet.
(Refer to **8. MAINTENANCE** on page 8.)

3. The air conditioner operates but it does not sufficiently cool or heat.

- Check if the air inlet or outlet of outdoor or indoor unit is blocked by obstacles.
Remove the obstacle and make it well-ventilated. Obstacles decrease the fan speed, and cause performance decrease and breakage when discharged air is suctioned.
They cause a waste of electricity, and that may stop the devices.
- Check if the air filter is clogged.
Ask a qualified service person to clean the air filters.
A decrease in the airflow volume of the air conditioner will result and the performance of the air conditioner will be degraded and power consumption will increase if the air filter is clogged with dust or dirt.
In addition, this may cause dew condensation at the air outlet.
(Refer to **8. MAINTENANCE** on page 8.)
- Check if the set temperature is not proper.
Set to an appropriate temperature and fan speed.
- Check if the FAN SPEED button is set to LOW SPEED.
Set to an appropriate temperature and fan speed.
- Check if the doors or the windows are open.
Shut doors or windows to prevent wind from coming in.

- Check if direct sunlight enters the room (when cooling).
Use curtains or blinds.
- When there are too many inhabitants in the room (when cooling).
- Check if the heat source of the room is excessive (when cooling).

4. Operation was performed or stopped although the ON/OFF button was not pressed.

- Are you sure that the ON/OFF timer operation is not used?
Turn off the ON/OFF timer.
Please refer to operation manual attached to the remote controller.
- Are you sure that any remote control device is not connected?
Contact the central control room that directed the stop.
- Are you sure that the display for centralized control is not lit?
Contact the central control room that directed the stop.

If the problem is not solved after checking the above points, please do not try to repair it yourself.

In such cases, always ask your local dealer.

At this time, please tell the symptom and model name (written on the model name plate).

If one of the following malfunctions occurs, take the measures shown below and contact your local dealer.

The air conditioner must be repaired by a qualified service person.

WARNING

When the air conditioner is malfunctioning (giving off a burning odour, etc.), turn off power to the air conditioner and contact your local dealer.

Continued operation under such circumstances may result in a failure, electric shocks or a fire.
Contact your local dealer.

- If a safety device such as a fuse, a power circuit breaker or an earth leakage breaker frequently actuates;
Measure: Do not turn on the main power switch.
- If the ON/OFF switch does not properly work;
Measure: Turn off the main power switch.
- If water leaks from the indoor unit.
Measure: Stop the operation.

- If a malfunction occurs, either one of the following messages will appear on the Basic screen on the wired remote controller during operation.

“Error: Push Menu button.”

(* The Operation lamp will blink.)

“Warning: Push Menu button.”

(* The Operation lamp will not blink.)

- Press Menu/Enter button.
The Malfunction (Error) code blinks.
For more information, refer to the operation manual attached to the remote controller.

Measure: Notify your local dealer and inform malfunction code of the display.

この図面は仕掛中です

H
3D138559
図番
DWG. NO

適合規格欄
APPLICABLE
STANDARD

ASB040004
GAZ007-X

INDOOR UNIT	
A1P,A2P,A3P,A4P,A5P	PRINTED CIRCUIT BOARD
C105	CAPACITOR
F1U	FUSE(T.3.15A,250V)
HAP	FLASHING LAMP(SERVICE MONITOR GREEN)
M1F	MOTOR(INDOOR UNIT FAN)
M1P	MOTOR (DRAIN PUMP)
M1S,M2S	MOTOR (HORIZONTAL SWING FLAPS)
M3S	MOTOR (VERTICAL SWING FLAPS)
CNX32,CNX31,X24A,CNX34,CNX35,CNX10, X27A,X801A,X36A,X30A,X18A,X17A, X15A,X25A,X16A,CNX20,CNX21,CNX11, X20A,CNX12,X25A,X15A,X16A,X17A,X2A, X1A,CN1	CONNECTOR
R1T	THERMISTOR (AIR)
R2T	THERMISTOR (HEAT EXCHANGER)
S1L	FLOAT SWITCH
V1R	DIODE BRIDGE
X1M	TERMINAL BLOCK (POWER SUPPLY)
X2M	TERMINAL BLOCK (R/C)
PS	SWITCHING POWER SUPPLY
Z1F	NOISE FILTER
X24A	CONNECTOR FOR WIRELESS RECEIVER
X801A	CONNECTOR FOR Wi-Fi ADAPTOR
BS1	PUSH BUTTON SWITCH
CN1,X1A,X2A	CONNECTOR
K2R	MAGNETIC RELAY
RC	RECEIVER
TC	TRANSMITTER

WIRING DIAGRAM

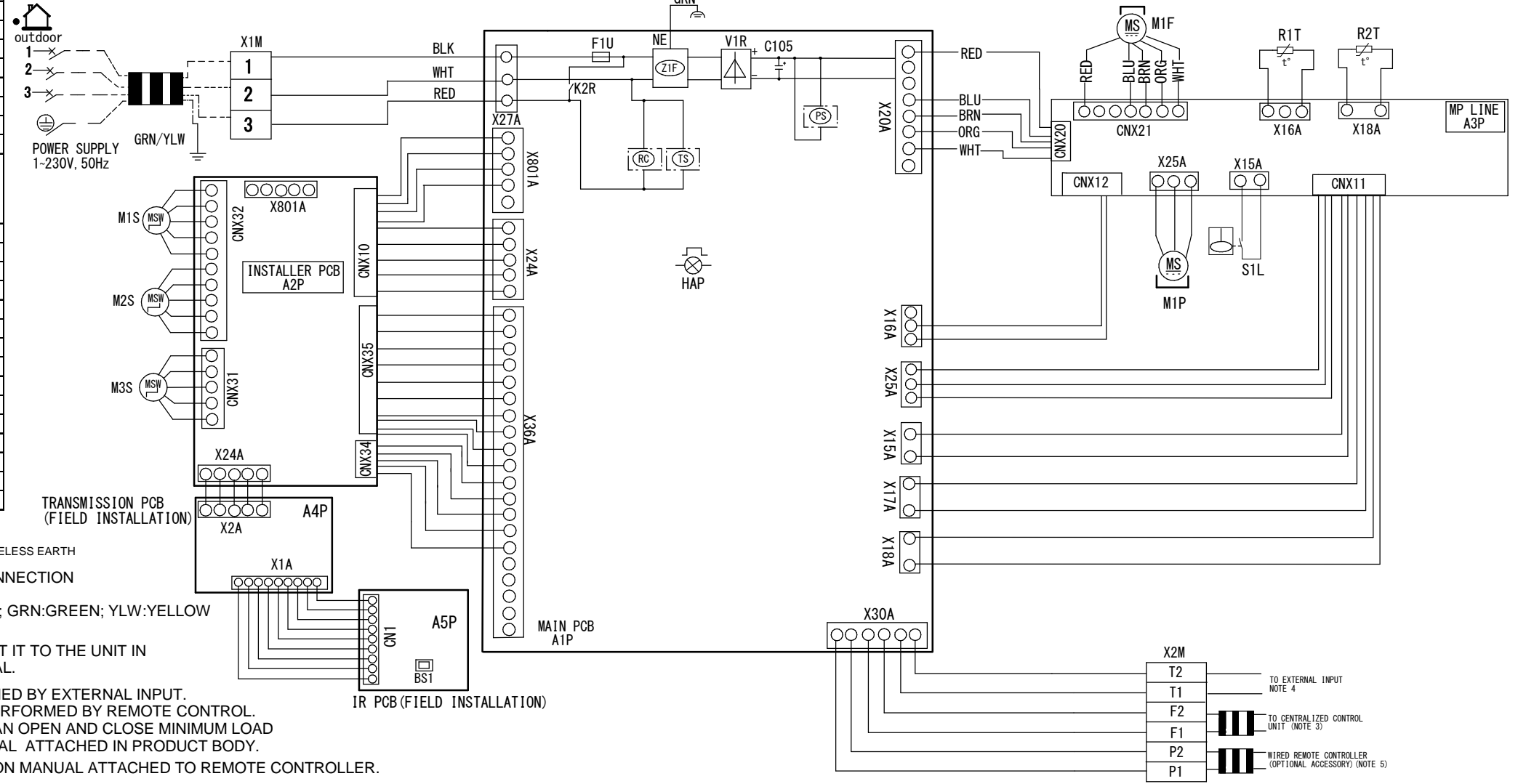

NOTES

- FIELD WIRING (indicated by thick lines) PROTECTIVE EARTH (indicated by a circle with a cross) NOISELESS EARTH (indicated by a circle with a cross and a diagonal line) TERMINAL BLOCK (indicated by a rectangle with a circle) CONNECTOR (indicated by a rectangle with a circle) CONNECTION (indicated by a solid line with a dot)
- COLOURS : BRN:BROWN; RED:RED; BLU:BLUE; WHT:WHITE; GRN:GREEN; YLW:YELLOW ORG: ORANGE; BLK:BLACK.
- IN CASE USING CENTRAL REMOTE CONTROLLER, CONNECT IT TO THE UNIT IN ACCORDANCE WITH THE ATTACHED INSTALLATION MANUAL.
- FORCING STOP OR ON/OFF OPERATION WILL BE PERFORMED BY EXTERNAL INPUT. FORCING STOP AND ON/OFF OPERATION SWITCHING IS PERFORMED BY REMOTE CONTROL. FOR EXTERNAL CONTACT PLEASE USE CONTACT THAT CAN OPEN AND CLOSE MINIMUM LOAD OF DC 15V 1mA. FOR DETAILS REFER INSTALLATION MANUAL ATTACHED IN PRODUCT BODY.
- IN CASE OF MAIN/SUB SWITCHING REFER THE INSTALLATION MANUAL ATTACHED TO REMOTE CONTROLLER.

3D138559-1H

NOTE:

SIZE : LENGTH 245 X WIDTH 95.
THIS DRAWING IS DRAWN ON CAD SYSTEM.

24/07/05

MODEL NAME
REMOVED FROM PART

24/06/01

FKCAQ50.71AV16
MODEL NAME ADDED

部番 PART	部品 管理記号 REVISION	一式分 個数 QUANT.	名称 PART NAME	材質 MATERIAL	記事 REMARK	JUDGE	CLASSIFY	電気安全責任 RESPONSIBLE FOR SAFETY OF ELECTRICITY.	UNIT mm	作成日 DATE	YR 21	MO 12	DA 17	尺度 SCALE	名称 NAME
50	H	1	電気配線図 WIRING DIAGRAM			2	A1	主回路検討書 MAIN CIRCUIT CHECKED RESULTS.		承認 APPROVED	照査 CHECKED	設計 DESIGNED	製図 DRAWN	WIRING DIAGRAM	
1	H	1	配線図銘板 WIRING DIAGRAM LABEL	(PRESSURE SENSITIVE) WOOD FREE PAPER 55kg/REAM		2	A1	チェックシート CheckSheet		承認 APPROVED	照査 CHECKED	設計 DESIGNED	製図 DRAWN	WIRING DIAGRAM	

DAIKIN AIRCONDITIONING INDIA PVT.LTD.

承認
APPROVED
B.Arora

照査
CHECKED
N.AMAR

設計
DESIGNED
Narender

製図
DRAWN
PUSHKAR

名称
NAME
WIRING DIAGRAM

電気配線図

PART CODE
943500

TYPICAL MODEL
FKCA50AV16

図番
DWG. NO
3D138559

H

この図面は仕掛中です

F
3D134441
図番 DWG. NO

適合規格欄
APPLICABLE
STANDARD
ASB040004

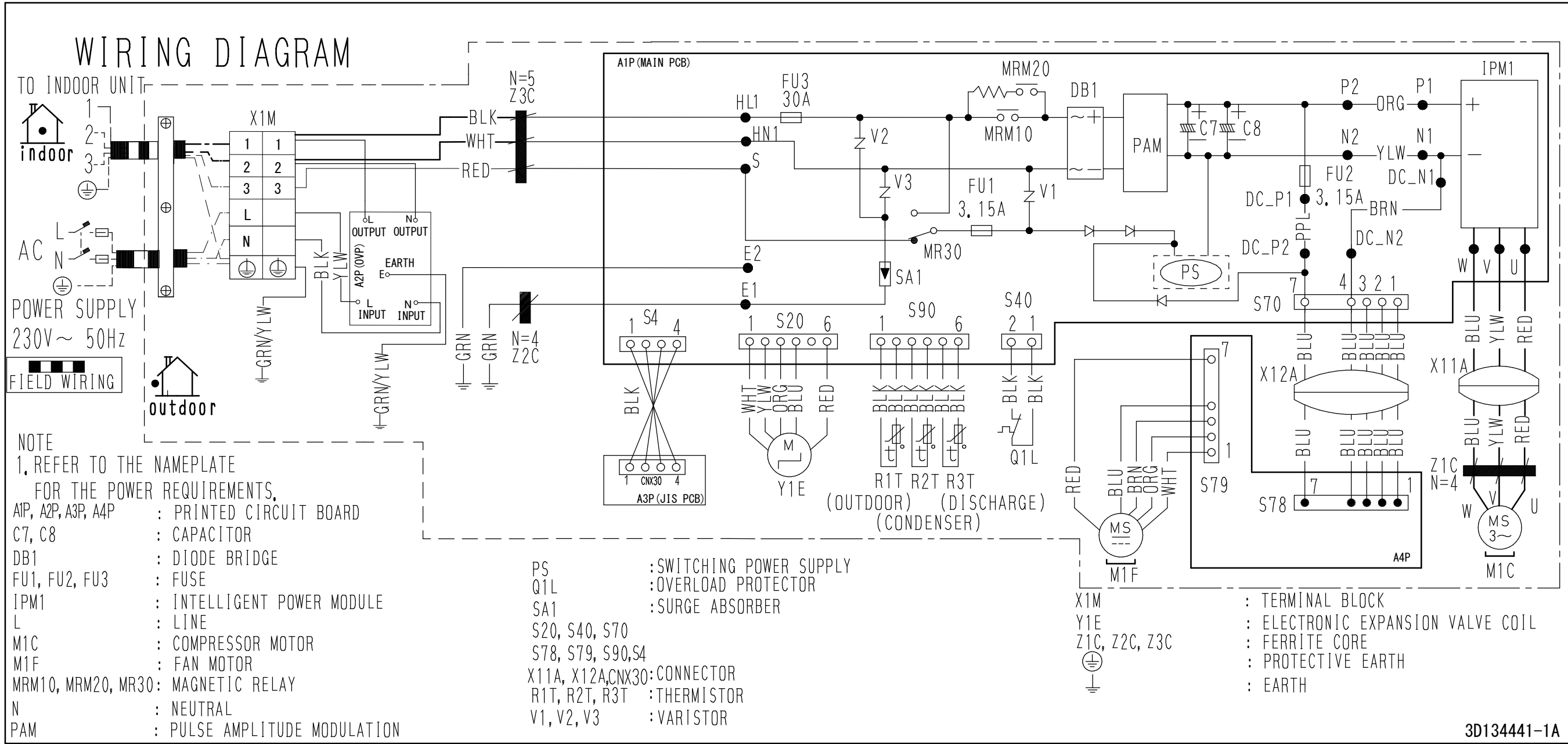

- NOTES) 1. SIZE: LENGTH 105 X WIDTH 185 .
 2. REFER TO PURCHASING SPECIFICATION AS(Y)303002, UNLESS OTHERWISE SPECIFIED.
 3. THIS DRAWING WAS DRAWN ON CAD SYSTEM.
 4. LETTER TYPE: PERMISSION TO USE GOTHIC TYPE.

26/09/25

適用機種名追記

ADDITION OF APPLICABLE MODEL NAMES

24/07/04

適用機種名追記

ADDITION OF APPLICABLE MODEL NAMES

24/07/04

部番 PART	部品管理記号 REVISION	一式分個数 QUANT.	名称 PART NAME	材質 MATERIAL	記事 REMARK	JUDGE	CLASSIFY	電気安全責任 RESPONSIBLE FOR SAFETY OF ELECTRICITY.	UNIT mm	作成日 DATE	YR MO DA	尺度 SCALE	名称 NAME	図番 DWG. NO
50	A	1	電気配線図 WIRING DIAGRAM			2	A1	主回路検討書 MAIN CIRCUIT CHECKED RESULTS.		承認 APPROVED	照査 CHECKED	設計 DESIGNED	製図 DRAWN	943500
1	A	1	配線図銘板 WIRING DIAGRAM LABEL			2	A1	チェックシート CheckSheet		P. Viksit	S. Kumar	OMPRAKASH	Satyam	943500
													名称 NAME	WIRING DIAGRAM
													名称 NAME	電気配線図
													PART CODE	943500
													TYPICAL MODEL	RZVFQ71AV16
													図番 DWG. NO	3D134441
														F

DAIKIN AIRCONDITIONING INDIA PVT. LTD.

DAIKIN**DAIKIN AIRCONDITIONING INDIA PVT. LTD.**

210, 1st FLOOR, OKHLA INDUSTRIAL AREA, PHASE 3, DELHI-110020

PROTECT THE ENVIRONMENT FROM E-WASTE (GUIDELINES)

Meaning of E-waste under E-Waste (Management) Rules,2022 (E-waste Rules)

-Waste electrical and electronic equipment, whole or in part of reject from their manufacturing and repair process, which are intended to be discarded.

Our product is RoHS compliant.



Don't dump Electrical and Electronic Products in Garbage Bins

DO'S & DONT'S

DO'S	
Run and maintain the air conditioner as per the instructions given in the operation / instruction manual	✓
Ensure that an authorised person repairs your air conditioner	✓
Call our local authorised dealer or our toll free number to dispose your air conditioner	✓
Contact an authorised dealer in case of installation or de-installation	✓
Consult our local authorised dealer or our toll free number on the life span of the air conditioner	✓
DONT'S	
Do not try to repair your air conditioner on your own	✗
Do not sell or dispose your air conditioner or parts to an unauthorised Kabbadi wala / Scrap Dealer / Ragpickers	✗
Do not dismantle your air conditioner on your own	✗
Do not get your air conditioner or any parts repaired by an unauthorised person	✗
Do not dispose off the E-waste in landfills	✗
Do not use the air conditioner as furniture after its use	✗

Customer Contact Center : 011-4031 9300/1860-180-3900

For further information visit us at www.daikinindia.com

- In the event that there is any conflict in the interpretation of this manual and any translation of the same in any language, the English version of this manual shall prevail.
- The manufacturer reserves the right to revise any of the specification and design contain herein at any time without prior notification.

DAIKIN AIRCONDITIONING INDIA PVT. LTD.

12th floor, Building No. 9,

Tower A, DLF Cyber City, DLF Phase-III

Gurgaon - 122002, Haryana (India)

Tel: 0124-4555444

Fax: 0124-4555333